

# FITTING GUIDE

## SUBARU WRX: HORN BRACKET

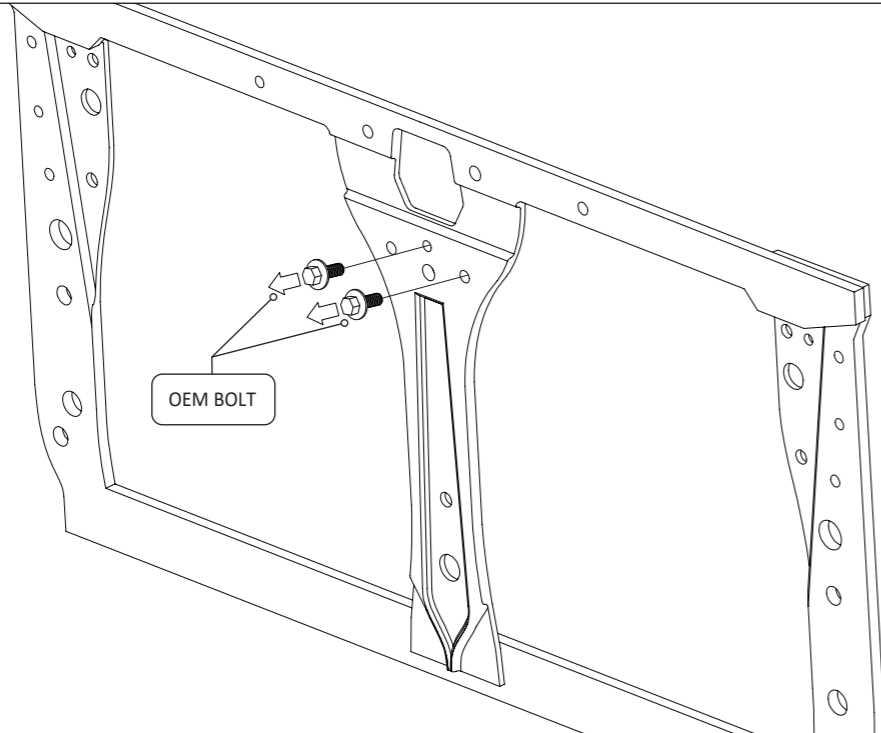

### STEP 1

- Once the radiator support bracket is accessible, remove OEM bolt shown in the above diagram and place aside OEM bolt from top hole for later use

### HANDY HINTS

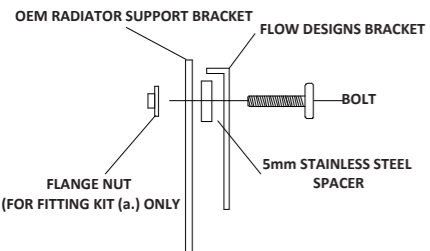

For correct installation, ensure to place 5mm spacer washer between Flow Designs horn bracket and OEM radiator support bracket

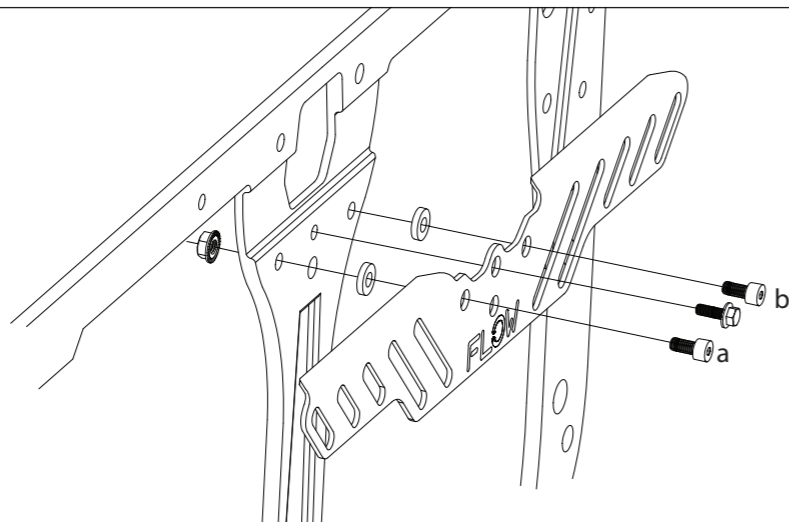

### STEP 2

- Using provided bolts and OEM bolt, fasten horn bracket to radiator support bracket
- Ensure bolt (a.) goes into left hole, bolt (b.) goes into right hole and OEM bolt is installed in the top hole.

## FITTING KIT

<p><b>a</b></p> <p>FLANGE NUT 5mm Stainless Steel Spacer</p>	<p><b>M8 CAP HEAD SCREW 20mm LONG X 1</b></p> <p>PLEASE NOTE: DRILLING NOT REQUIRED TO FASTEN TO BRACKET USES OEM HOLE</p>	<p><b>b</b></p> <p>5mm Stainless Steel Spacer</p>	<p><b>M8 CAP HEAD SCREW 20mm LONG X 1</b></p> <p>PLEASE NOTE: DRILLING NOT REQUIRED TO FASTEN TO BRACKET REPLACES OEM BOLT</p>
--	--	---	--

### INSTALLATION AND FITTING SERVICES

If you are having any difficulties please seek professional advice from the listed International and Domestic Authorised Dealers on our website.

[www.flowdesignsaustralia.com](http://www.flowdesignsaustralia.com)

## BUMPER REMOVAL MAY BE REQUIRED

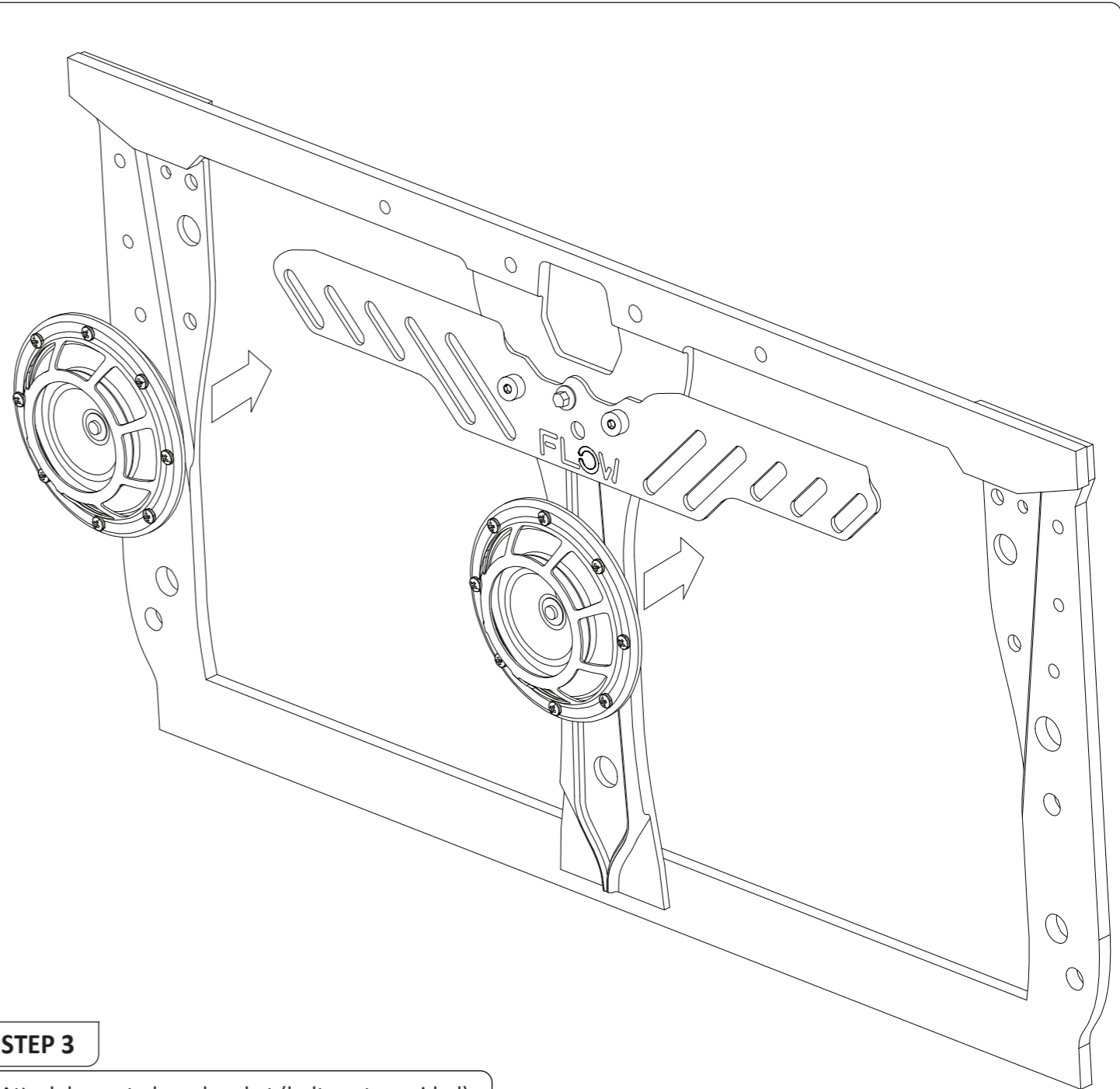

### STEP 3

- Attach horns to horn bracket (bolts not provided)

**FLOW DESIGNS**  
FLOW DESIGNS AUSTRALIA  
 ABN : 99 805 842 199  
 10 LONGSTAFF RD  
 BAYSWATER  
 VIC, 3153

DESIGNED AND MANUFACTURED IN AUSTRALIA

**TERMS AND CONDITIONS : MISUSE OF GOODS**  
 This Product application is not intended for public road registered vehicles within Australia. Regulations may vary from Countries outside of Australia. Please check your Country's and State's road regulations before installing on a vehicle intended for public road use.  
 Flow Designs Australia PTY LTD will not be liable for any liabilities in relation to any use of the goods other than in strict accordance with the Company's instructions and for the purpose and application for which the goods were supplied by the Company.  
 The Client undertakes with the Company:  
 • That it will acquaint itself with the requirements of all relevant government or statutory and other authorities, bodies or corporations relating to the goods and/or services and to the applications to which the goods and/or services are to be put;  
 • That at all times while the goods are in its possession or under its control it will comply with such requirements;  
 • That it will procure that any purchaser of goods from it will also acquaint itself with, and will comply with, such requirements;  
 • That it will indemnify the Company against any liability resulting from a breach of any such requirements.

[www.flowdesignsaustralia.com](http://www.flowdesignsaustralia.com)