

# FITTING DIAGRAM

## SUBARU VB WRX SEDAN: FRONT AIR DEFLECTOR INSTRUCTIONS

### INSTALLATION AND FITTING SERVICES

If you are having any difficulties please seek professional advice from the listed International and Domestic Authorised Dealers on our website.

www.flowdesignsaustralia.com

# BUMPER REMOVAL NOT REQUIRED

### INSTALLATION NOTE - FRONT AIR DEFLECTOR

Front Air Deflector is reversible and adjustable. Pick between Gloss or Textured finish before mounting Air Deflector.

To adjust the position of the deflector, loosen mounting bolts and slide deflector in or outwards. Tighten bolts to secure Front Air Deflector.

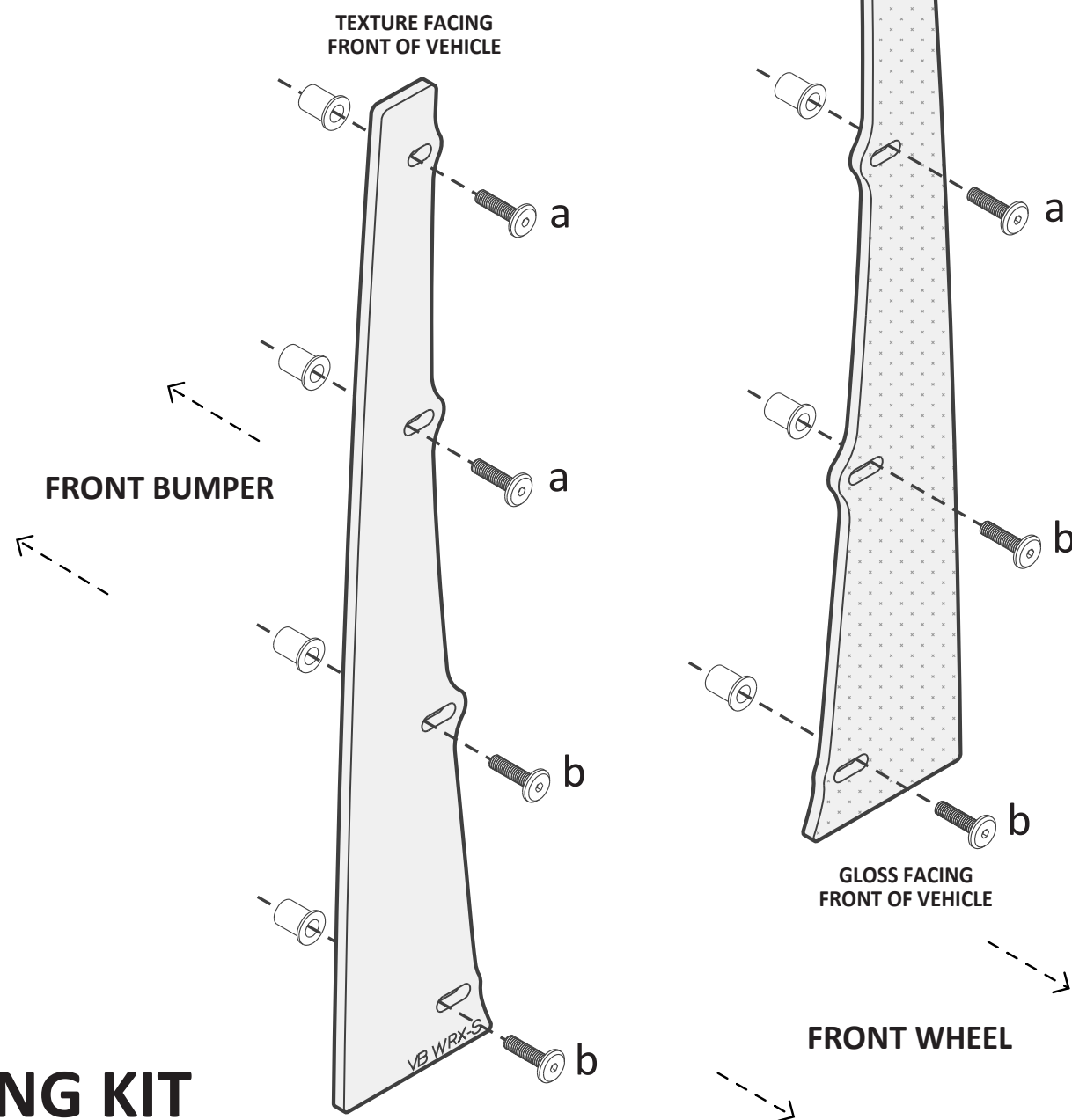

## FITTING KIT

**a**

M5 BOLT  
20mm LONG

**X 4**

PLEASE NOTE:  
REMOVE OEM CLIP  
AND USE OEM HOLE.  
ENLARGE HOLE USING  
10MM DRILL BIT

**b**

M5 BOLT  
20mm LONG

**X 4**

PLEASE NOTE:  
DRILLING INTO  
BUMPER REQUIRED  
USE 10MM DRILL BIT

**FLOW** DESIGNS

FLOW DESIGNS AUSTRALIA  
ABN : 99 605 842 199  
10 LONGSTAFF RD  
BAYSWATER  
VIC, 3153

DESIGNED AND MANUFACTURED IN AUSTRALIA

**TERMS AND CONDITIONS: MISUSE OF GOODS**  
By taking possession of the Flow Designs Australia product, you (the buyer) agree that you have read, understood and will comply with the following disclaimer:

- This product may not be suitable for road use in your area. We cannot be held liable for any penalties or infringements that may occur after installing any of our products.
- We cannot guarantee that this product will comply with all subsequent aftermarket products you have applied to your vehicle.
- It is not legal to fit parts onto a road registered vehicle unless it carries and meets the designs rules and public road regulations of your area, region and/or country.
- We do our best effort to consider safety when designing our products. We want the scene to be a safe place for everyone!

This disclaimer absolves us (Flow Designs Australia) of any and all liability or breaches to any requirement as a result of installation of our products.

www.flowdesignsaustralia.com

### STEP 1

- Turn front wheel to the side to **access OEM clips on the front bumper**.
- **Remove 2 OEM clips** from the front bumper.
- Using a **10mm drill bit** enlarge OEM hole.
- **Thread rubber nuts for mounting bolts (a)** onto the bot through the air deflector.
- **Insert the rubber nuts for the top 2 mounting holes** before tightening bolts.

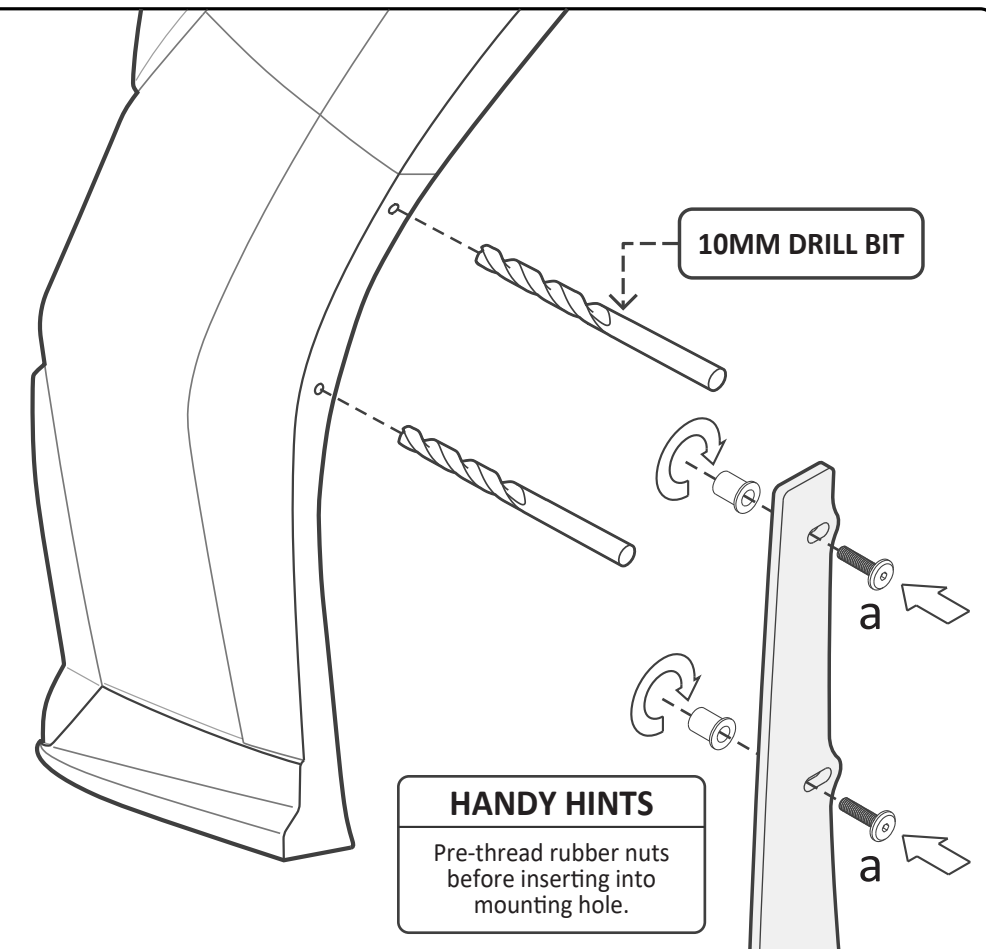

### STEP 2

- With the deflector temporarily mounted, **mark and drill out lower 2 mounting holes** using **10mm drill bit**.
- Loosen rubber nuts and **temporarily remove the Air Deflector**.
- **Thread rubber nuts for mounting bolts (b)** onto the bolt through the air deflector.
- **Align the air deflector** with the edge of the bumper.
- Insert and **tighten rubber nuts from top to bottom**.

