

FITTING DIAGRAM

SUBARU VB WRX SEDAN: REAR DIFFUSER + FLOW LOCK FINS INSTRUCTIONS

INSTALLATION AND FITTING SERVICES

If you are having any difficulties please seek professional advice from the listed International and Domestic Authorised Dealers on our website.

www.flowdesignsaustralia.com

BUMPER REMOVAL NOT REQUIRED

HANDY HINTS

Align back edge of diffuser with OEM rear bumper.

HANDY HINTS

Remove OEM clip before installation of diffuser. Mount bolts through OEM hole in the bumper and OEM bracket.

INSTALLATION GUIDE FITTING KIT - B

3D PRINTED SPACER

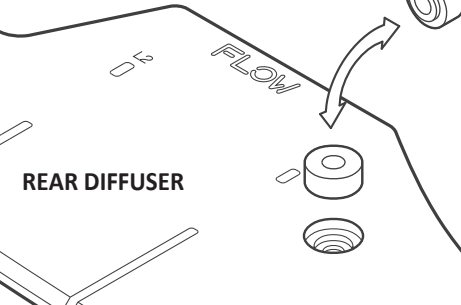

Install 3d printed spacer with top lip facing down as shown in diagram above prior to installation of diffuser. Push spacer into hole to lock into place.

HANDY HINTS

To mount centre bolts, carefully pry plastic bumper down to access mounting bolts. Mount through OEM bracket and hole.

HANDY HINTS

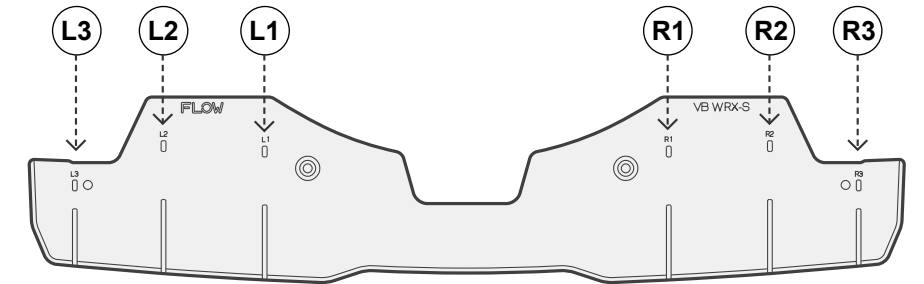

- Align FLOW-LOCK Fins to their corresponding slots.
- Please ensure to allocate the correct FLOW-LOCK Fin to the correct corresponding slot (L1 into L1 slot, R1 into R1 slot etc.)
- Ensure textured side of fin is facing out from opposing fin
- Push fin in firmly into the slots until a clicking sound is heard.
- Check both top and bottom locking tabs have securely seated

Please Note: Once fins have been locked into position, they will be difficult to remove.

INSTRUCTIONAL VIDEO QR CODE



HANDY HINTS

For best alignment, install diffuser fins after mounting the diffuser.

FITTING KIT

a

M6 BOLT
35mm LONG

X 2

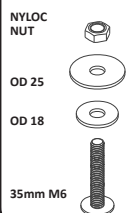

PLEASE NOTE:
REMOVE OEM CLIP
AND USE OEM HOLE.
NO DRILLING REQUIRED

b

M6 BOLT
40mm LONG

X 2

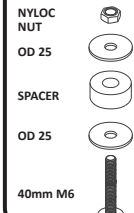

PLEASE NOTE:
REMOVE OEM CLIP
AND USE OEM HOLE.
NO DRILLING REQUIRED

HANDY HINTS

Ensure diffuser fin locking tabs are pushed all the way in and clipped into the diffuser.

FLOW-LOCK
TECHNOLOGY



TERMS AND CONDITIONS: MISUSE OF GOODS
By taking possession of the Flow Designs Australia product, you (the buyer) agree that you have read, understood and will comply with the following disclaimer:

- This product may not be suitable for road use in your area. We cannot be held liable for any penalties or infringements that may occur after installing any of our products.
- We cannot guarantee that this product will comply with all subsequent aftermarket products you have applied to your vehicle.
- It is not legal to fit parts onto a road registered vehicle unless it carries and meets the design rules and public road regulations of your area, region and/or country.
- We do our best effort to consider safety when designing our products. We want the scene to be a safe place for everyone!

This disclaimer absolves us (Flow Designs Australia) of any and all liability or breaches to any requirement as a result of installation of our products.

www.flowdesignsaustralia.com