

# FITTING GUIDE - PAGE 1

SUBARU G3 WRX HATCH - REAR SPATS + ADJUSTABLE WINGLETS

INSTALLATION AND FITTING SERVICES

If you are having any difficulties please seek professional advise from the listed International and Domestic Authorised Dealers on our website.

[www.flowdesignsaustralia.com](http://www.flowdesignsaustralia.com)

## BUMPER REMOVAL NOT REQUIRED

## SUBARU G3 WRX HATCH - REAR MUDGUARD JACK NUT INSTALLATION GUIDE

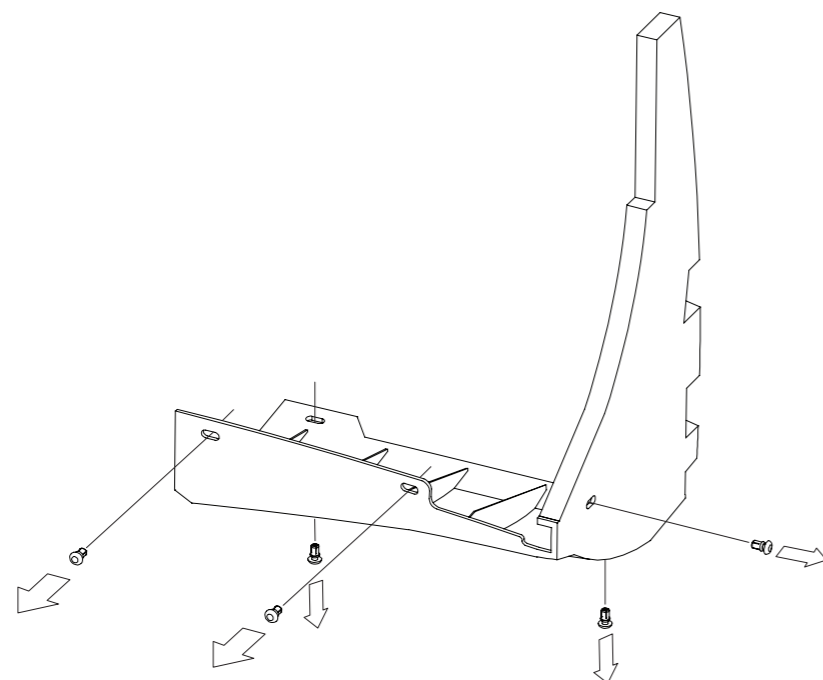

### STEP 1

- Locate both left and right OEM rear wheel mudguards and the 5 push clips attaching mudguards to car
- Remove the four push clips to release mudguard from car (applies to both left and right side mudguard)

### HANDY HINTS

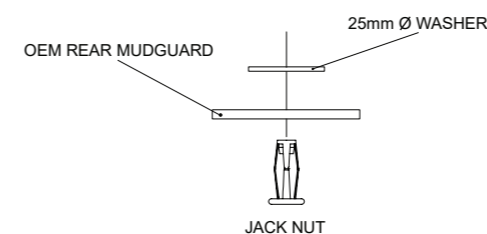

- Insert Jack Nut through outside of OEM Rear Mudguard
- Ensure washer is placed on the inside of OEM Rear Mudguard.

### STEP 2

- Using an 11mm drill bit, drill bottom two OEM holes to ensure proper jack nut fitment
- Insert jack nuts into bottom two holes to replace push clips, ensuring to use provided washers for extra strength

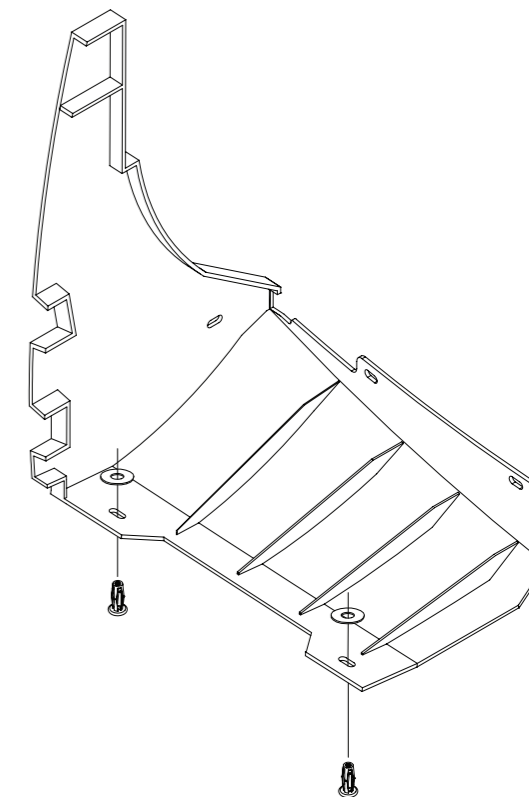

### STEP 3a

ENSURE TO INSERT JACK NUT THROUGH HOLE IN OEM REAR MUDGUARD BEFORE COMPRESSING

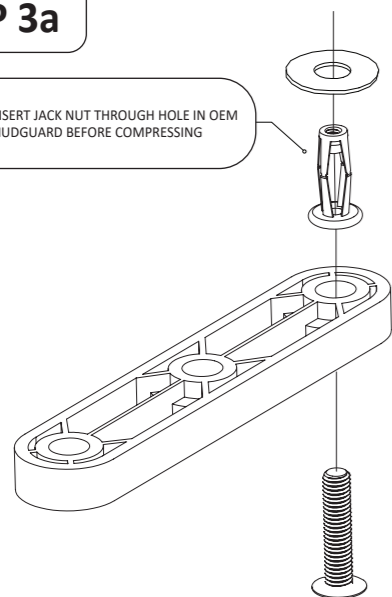

### STEP 3b

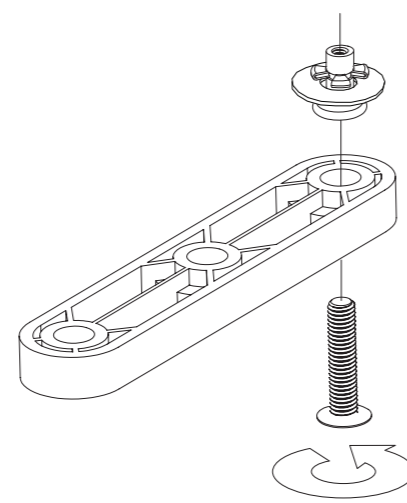

- Using provided Flow Designs Jack Nut Compression Tool, install jack nuts from STEP 2 into the OEM holes in the OEM side skirt
- Please ensure that the jack nut is firmly inserted into pre-drilled holes in OEM side skirt

### STEP 4

- Reinstall OEM Rear Mudguard by replacing push clips in the three remaining holes not used by previously installed Jack Nuts

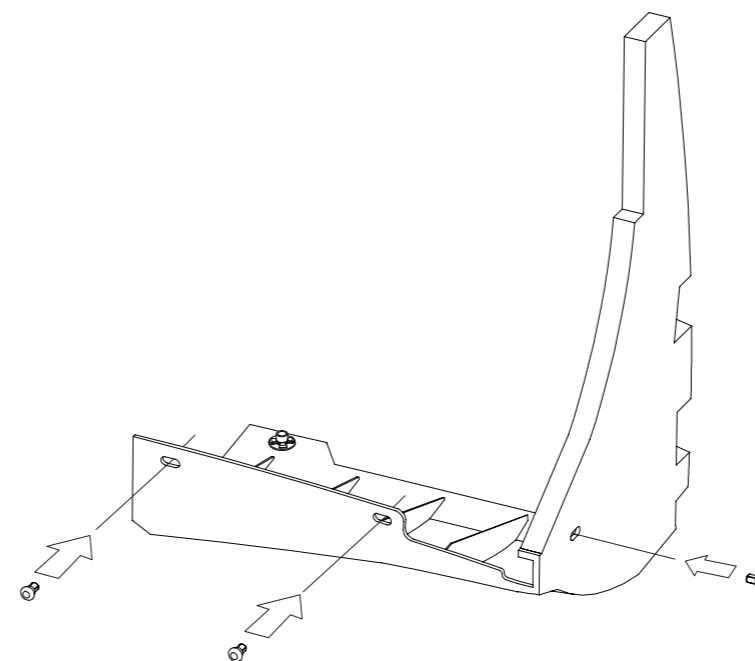

To install splitter continue to page 2

**FLOW**  
DESIGNS

FLOW DESIGNS AUSTRALIA  
ABN: 99 605 842 199  
FACTORY #1  
6-7 NICOLE CLOSE  
BAYSWATER NORTH  
VIC 3153



#### TERMS AND CONDITIONS : MISUSE OF GOODS

This Product application is not intended for public road registered vehicles within Australia. Regulations may vary from Countries outside of Australia. Please check your Country's and State's road regulations before installing on a vehicle intended for public road use.

Flow Designs Australia PTY LTD will not be liable for any liabilities in relation to any use of the goods other than in strict accordance with the Company's instructions and for the purpose and application for which the goods were supplied by the Company.

- The Client undertakes with the Company:
- That it will acquaint itself with the requirements of all relevant government or statutory and other authorities, bodies or corporations relating to the goods and/or services and to the applications to which the goods and/or services are to be put.
  - That at all times while the goods are in its possession or under its control it will comply with such requirements.
  - That it will procure that any purchaser of goods from it will also acquaint itself with, and will comply with, such requirements.
  - That it will indemnify the Company against any liability resulting from a breach of any such requirements.

[www.flowdesignsaustralia.com](http://www.flowdesignsaustralia.com)

# FITTING DIAGRAM - PAGE 2

SUBARU G3 WRX HATCH REAR SPATS + ADJUSTABLE REAR WINGLETS

INSTALLATION AND FITTING SERVICES

If you are having any difficulties please seek professional advise from the listed International and Domestic Authorised Dealers on our website.

[www.flowdesignsaustralia.com](http://www.flowdesignsaustralia.com)

**BUMPER REMOVAL  
NOT REQUIRED**

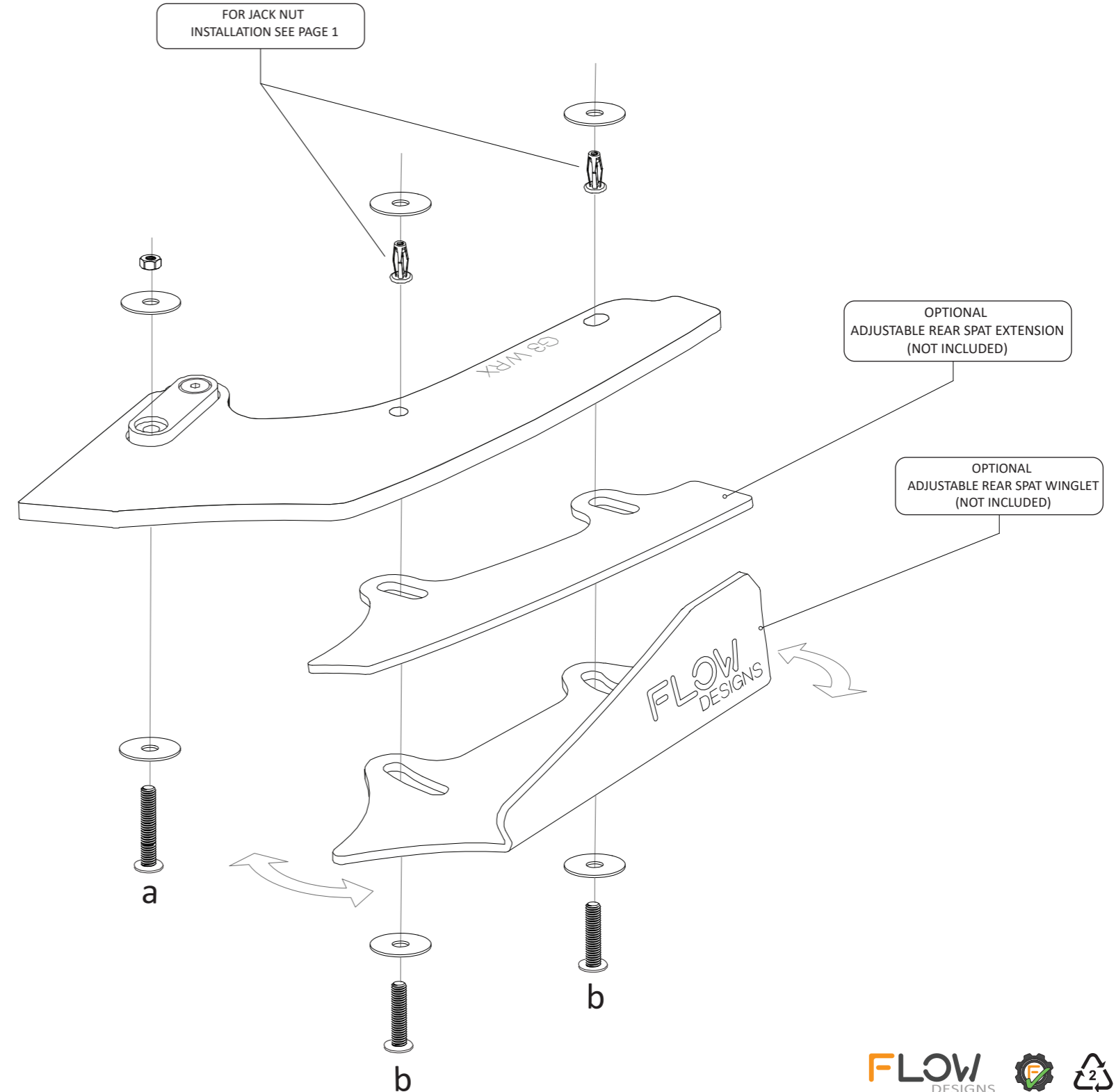
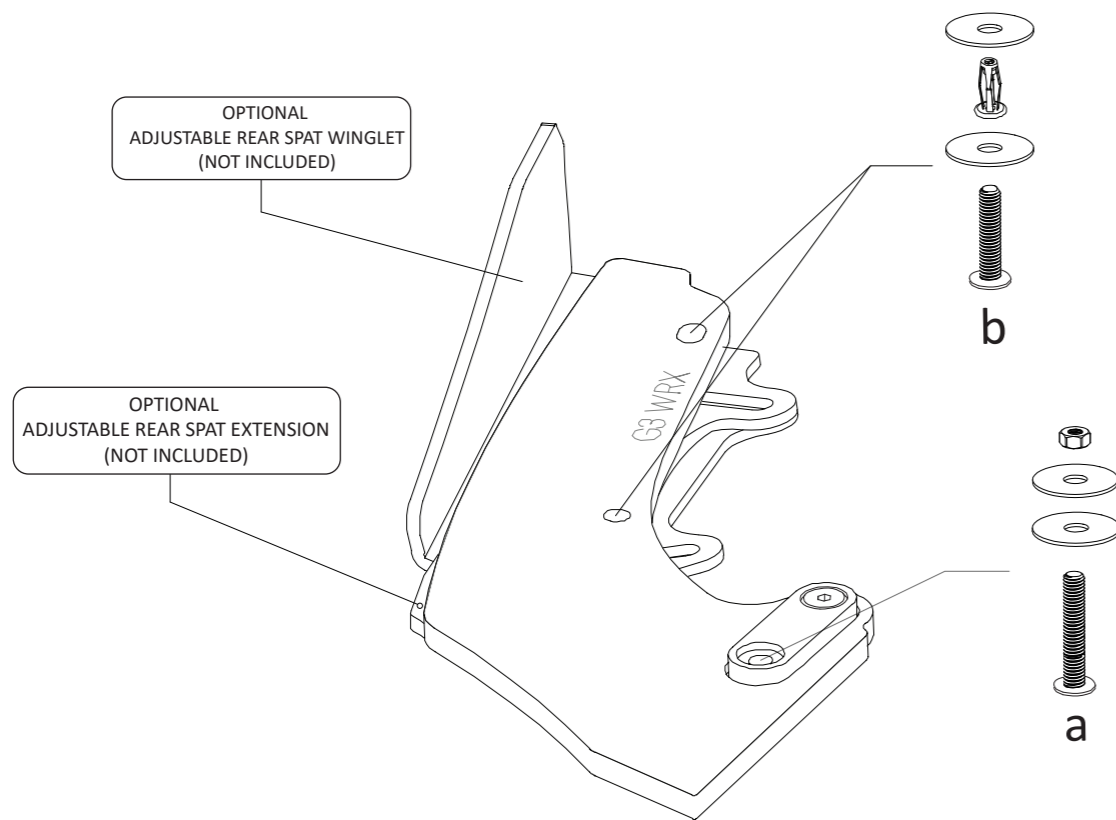

## FITTING KIT

**a**

**M6 BOLT  
40mm LONG**

**X 2**

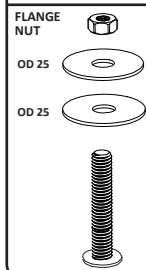

PLEASE NOTE:  
DRILLING REQUIRED  
TO FASTEN TO BUMPER  
PLEASE USE 8mm DRILL BIT

**b**

**M6 BOLT  
30mm LONG**

**X 4**

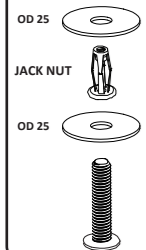

PLEASE NOTE:  
DRILLING NOT REQUIRED  
TO FASTEN TO BUMPER  
PLEASE USE 8mm DRILL BIT