

FITTING GUIDE - PAGE 1

SUBARU G3 WRX/RS NB HATCH - REAR SPATS + ADJUSTABLE WINGLETS

INSTALLATION AND FITTING SERVICES

If you are having any difficulties please seek professional advise from the listed International and Domestic Authorised Dealers on our website.

www.flowdesignsaustralia.com

**BUMPER REMOVAL
NOT REQUIRED**

SUBARU G3 WRX/RS NB HATCH - REAR MUDGUARD JACK NUT INSTALLATION GUIDE

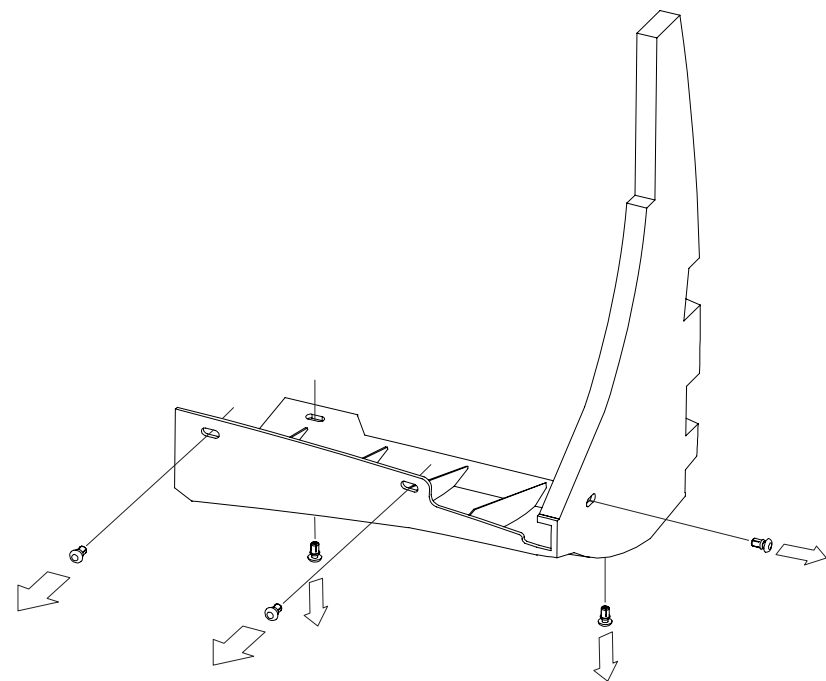

STEP 1

- Locate both left and right OEM rear wheel mudguards and the 5 push clips attaching mudguards to car
- Remove the four push clips to release mudguard from car (applies to both left and right side mudguard)

STEP 2

- Using an 11mm drill bit, drill bottom two OEM holes to ensure proper jack nut fitment
- Insert jack nuts into bottom two holes to replace push clips, ensuring to use provided washers for extra strength

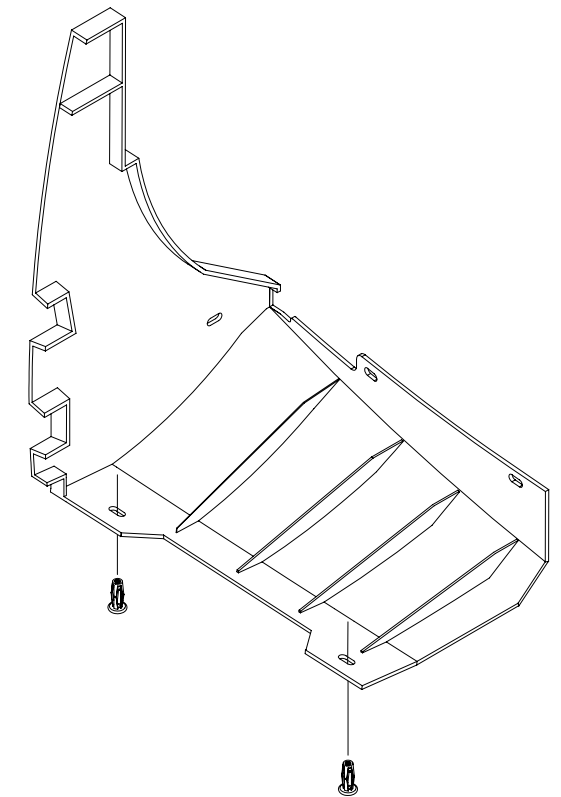

STEP 3a

ENSURE TO INSERT JACK NUT THROUGH HOLE IN OEM REAR MUDGUARD BEFORE COMPRESSING

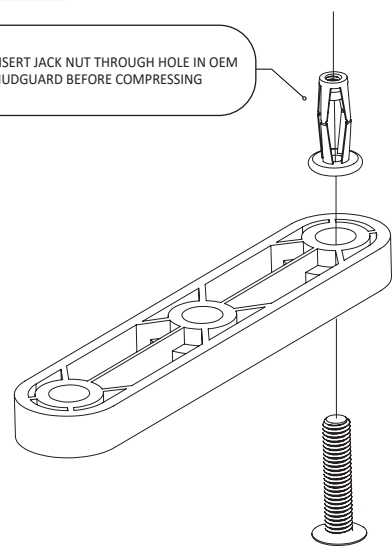

STEP 3b

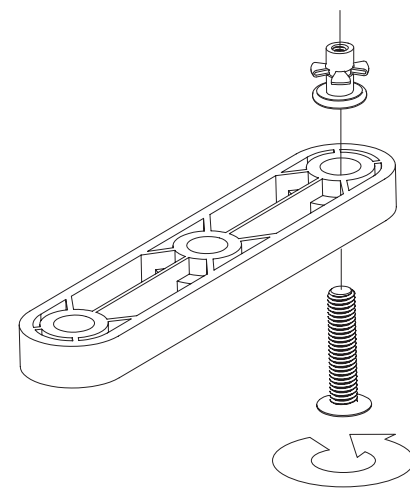

- Using provided Flow Designs Jack Nut Compression Tool, install jack nuts from STEP 2 into the OEM holes in the OEM side skirt
- Please ensure that the jack nut is firmly inserted into pre-drilled holes in OEM side skirt

STEP 4

- Reinstall OEM Rear Mudguard by replacing push clips in the three remaining holes not used by previously installed Jack Nuts

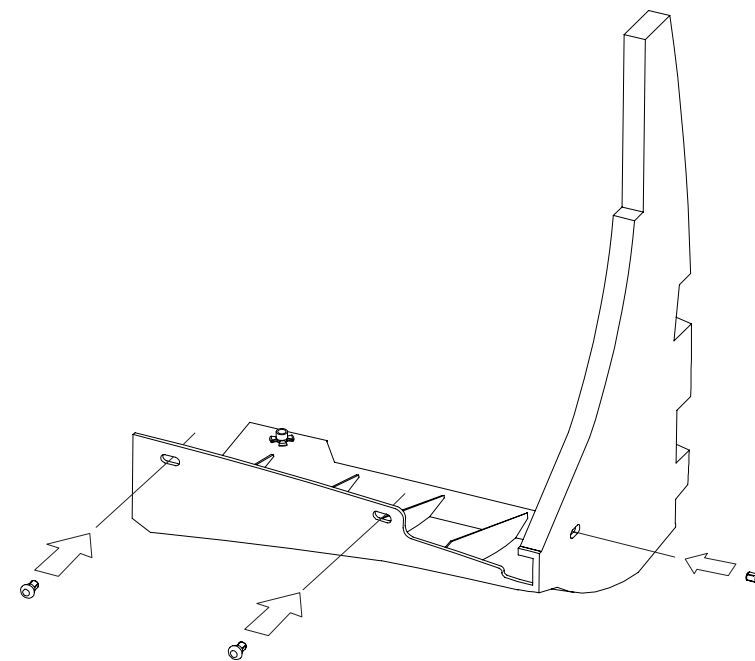

To install splitter
continue to page 2

FLOW
DESIGNS

FLOW DESIGNS AUSTRALIA
AABN: 99 505 842 199
FACTORY 11
6-7 NICOLE CLOSE
BAYSWATER NORTH VIC. 3153



TERMS AND CONDITIONS : MISUSE OF GOODS

This Product application is not intended for public road registered vehicles within Australia. Regulations may vary from Countries outside of Australia. Please check your Country's and State's road regulations before installing on a vehicle intended for public road use.

Flow Designs Australia PTY LTD will not be liable for any liabilities in relation to any use of the goods other than in strict accordance with the Company's instructions and for the purpose and application for which the goods were supplied by the Company. The Client undertakes with the Company:
• That it will acquaint itself with the requirements of all relevant government or statutory and other authorities, bodies or corporations relating to the goods and/or services and to the applications to which the goods and/or services are to be put;
• That at all times while the goods are in its possession or under its control it will comply with such requirements;
• That it will procure that any purchaser of goods from it will also acquaint itself with, and will comply with, such requirements;
• That it will indemnify the Company against any liability resulting from a breach of any such requirements.
www.flowdesignsaustralia.com

FITTING DIAGRAM - PAGE 2

SUBARU G3 WRX/RS NB HATCH REAR SPATS + ADJUSTABLE REAR WINGLETS

INSTALLATION AND FITTING SERVICES

If you are having any difficulties please seek professional advice from the listed International and Domestic Authorised Dealers on our website.

www.flowdesignsaustralia.com

**BUMPER REMOVAL
NOT REQUIRED**

OPTIONAL
ADJUSTABLE REAR SPAT WINGLET
(NOT INCLUDED)

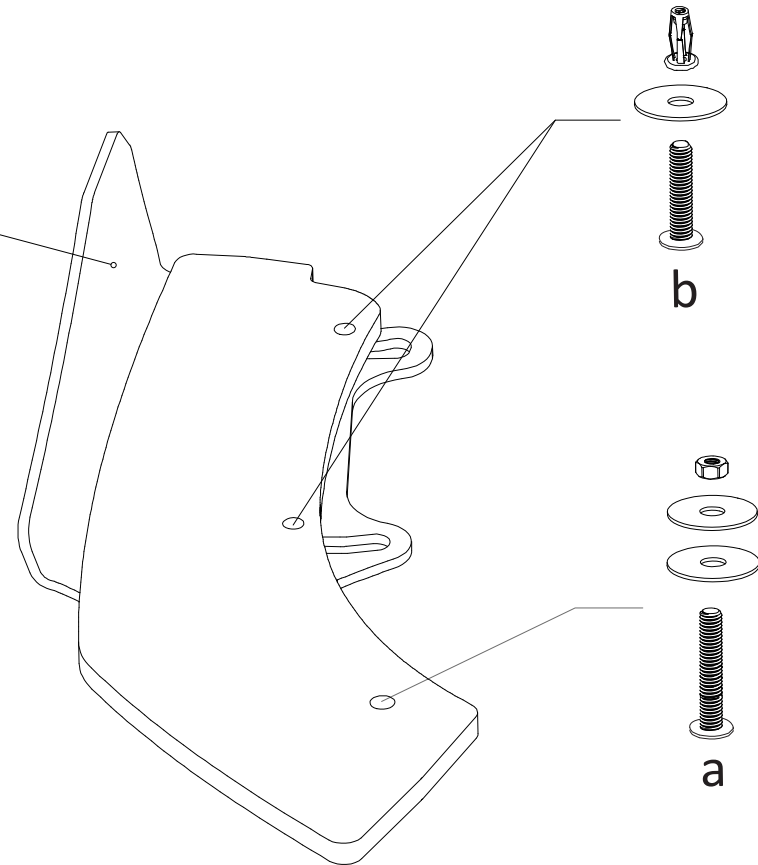

FOR JACK NUT
INSTALLATION SEE PAGE 1

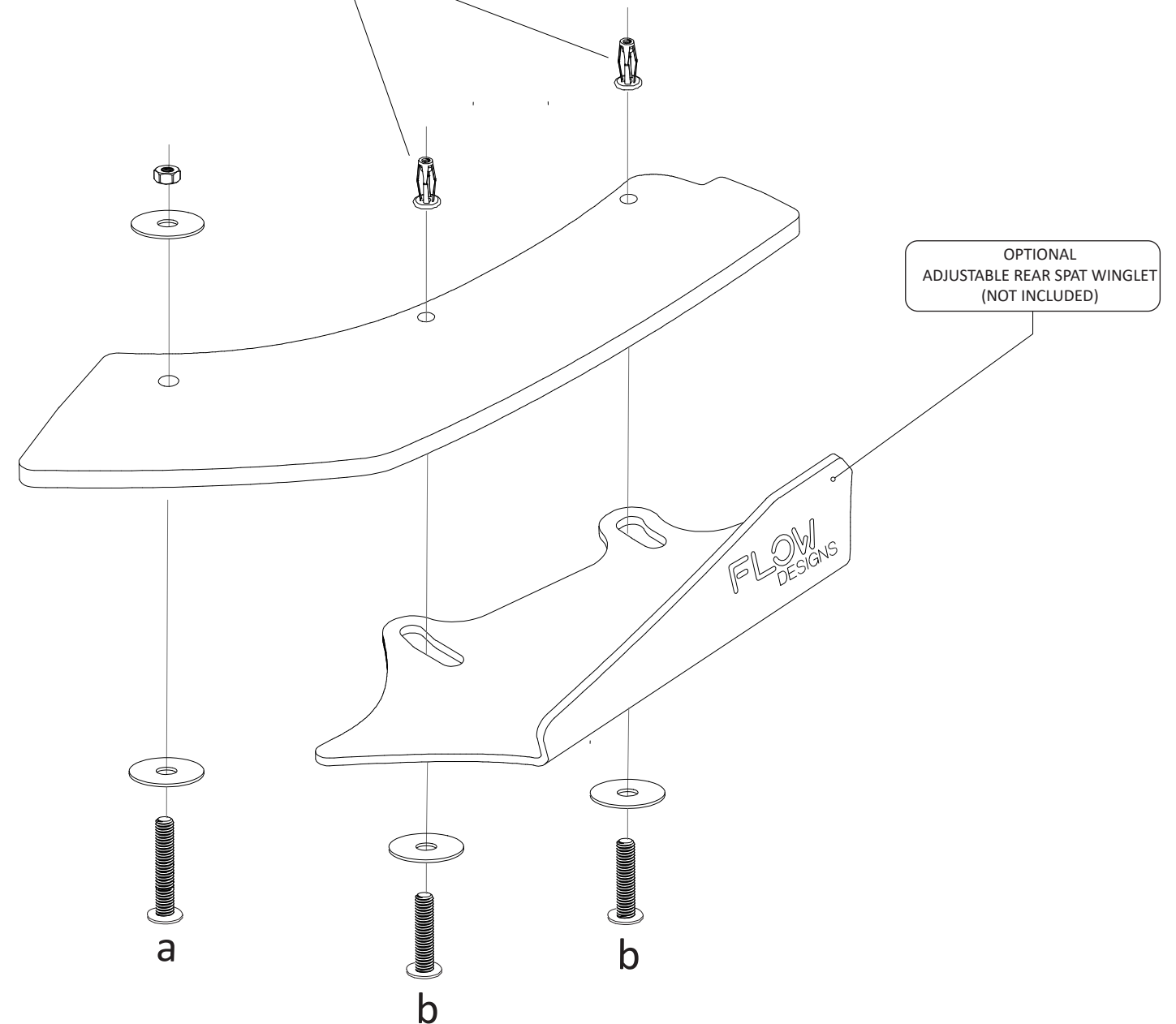

FITTING KIT

a

**M6 BOLT
30mm LONG**

X 2

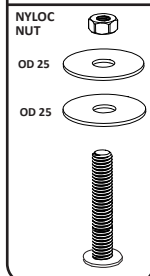

PLEASE NOTE:
DRILLING REQUIRED
TO FASTEN TO BUMPER

PLEASE USE 8mm DRILL BIT

b

**M6 BOLT
30mm LONG**

X 4

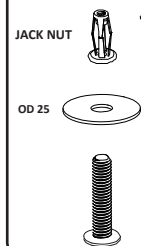

PLEASE NOTE:
DRILLING REQUIRED
TO FASTEN TO BUMPER

PLEASE USE 11mm DRILL BIT