

# FITTING GUIDE - PAGE 1

KIA STINGER GT - FRONT SPLITTER INSTRUCTIONS

INSTALLATION AND FITTING SERVICES

If you are having any difficulties please seek professional advise from the listed International and Domestic Authorised Dealers on our website.

[www.flowdesignsaustralia.com](http://www.flowdesignsaustralia.com)

**BUMPER REMOVAL  
NOT REQUIRED**

## KIA STINGER GT - FRONT OEM LIP REINFORCEMENT BRACKET INSTRUCTIONS

### STEP 1

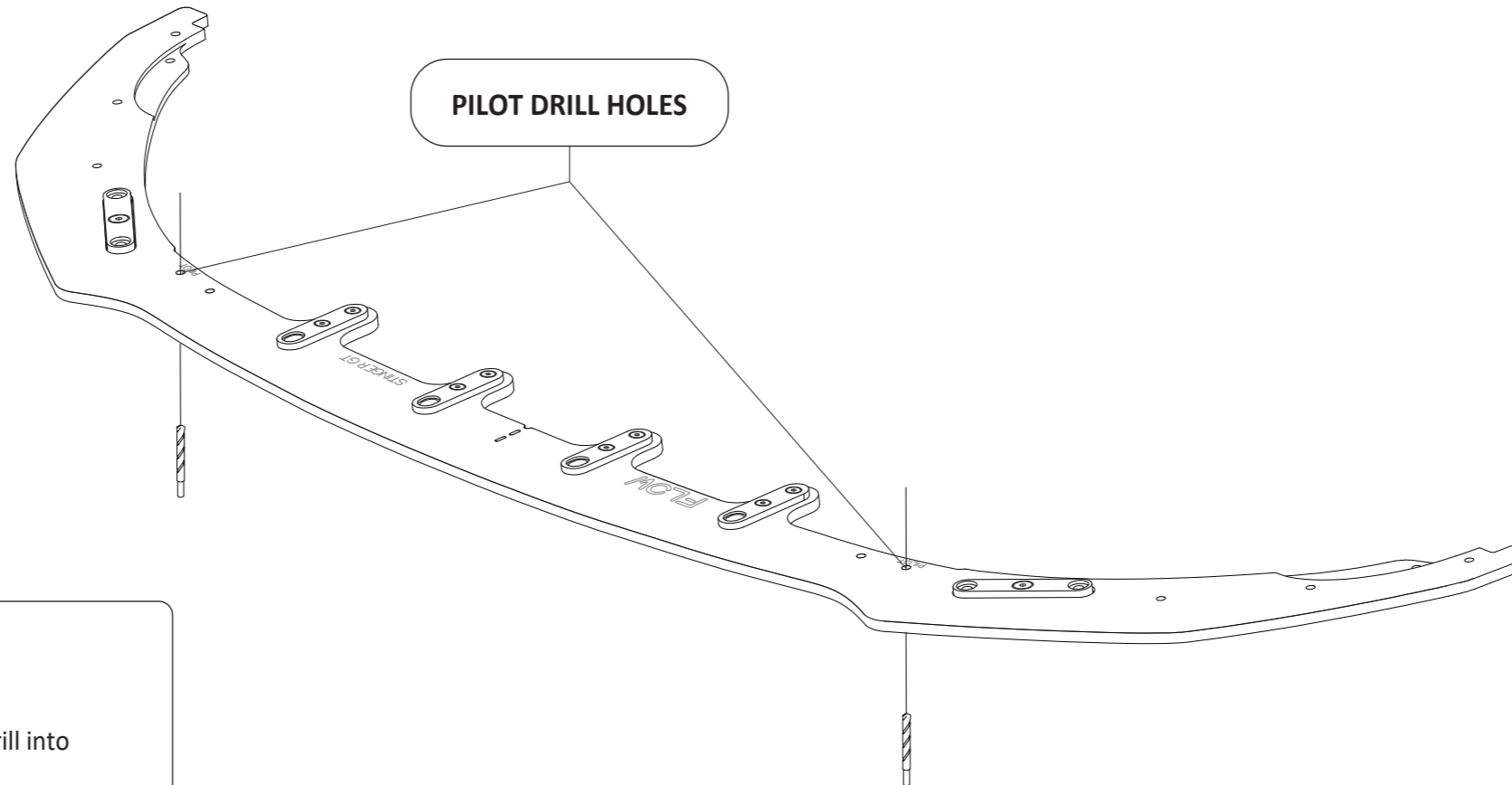

### STEP 1

- Remove OEM undertray
- Align front splitter with OEM bumper
- Using an 8mm drill bit and the front splitter as a template, drill into OEM bumper through holes marked 'pilot'

**PLEASE NOTE :** Drill bottom side of the front splitter

### STEP 2

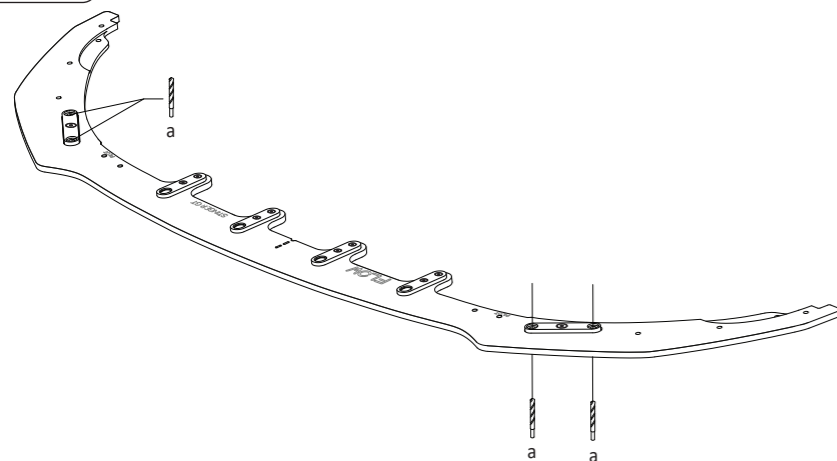

- Using an 8mm drill bit and the front splitter as a template, drill into OEM bumper through holes marked (a.)
- Remove Splitter from OEM bumper

**PLEASE NOTE :** Drill bottom side of the front splitter

### STEP 3

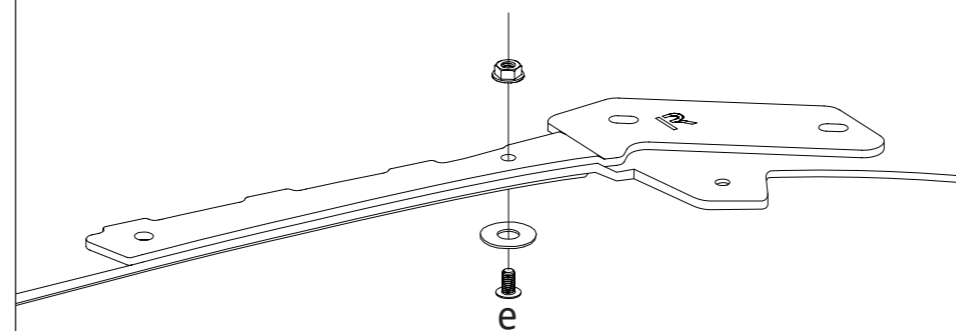

- Place both left and right brackets on inside of OEM bumper, aligning holes with previously drilled holes
- Using bolts (e.), fasten both left and right bracket directly to OEM bumper

**To install splitter  
continue to page 2**



**TERMS AND CONDITIONS : MISUSE OF GOODS**  
By taking possession of this Flow Designs Australia product, you (the buyer) agree that you have read, understood and will comply with the following disclaimer:  
This product may not be suitable for road use in your area. We cannot be held liable for any penalties or infringements that may occur as a result of installing any of our products.  
We cannot guarantee that this product will comply with subsequent aftermarket products you have applied to your vehicle.  
It is not legal to fit parts onto a road registered vehicle unless it carries and meets the design rules and public road regulations of your area, region and/or country.  
We do make our best effort to consider safety when designing our products, we want the scene to be a safe place for everyone!  
This disclaimer absolves us (Flow Designs Australia) of any and all liability for breaches to any requirement as a result of installation of our products.  
[www.flowdesignsaustralia.com](http://www.flowdesignsaustralia.com)

# FITTING DIAGRAM - PAGE 2

## KIA STINGER GT - FRONT SPLITTER

INSTALLATION AND FITTING SERVICES

If you are having any difficulties please seek professional advise from the listed International and Domestic Authorised Dealers on our website.

[www.flowdesignsaustralia.com](http://www.flowdesignsaustralia.com)

# BUMPER REMOVAL NOT REQUIRED

### FITTING KIT

**a** M6 BOLT  
20mm LONG

**X 2**

PLEASE NOTE:  
DRILLING NOT REQUIRED  
TO FASTEN TO BUMPER  
DO NOT OVERTIGHTEN

**b** M6 BOLT  
20mm LONG

**X 4**

PLEASE NOTE:  
DRILLING REQUIRED  
TO FASTEN TO BUMPER  
DO NOT OVERTIGHTEN

**c** M6 BOLT  
30mm LONG

**X 4**

PLEASE NOTE:  
DRILLING REQUIRED  
TO FASTEN TO BUMPER  
DO NOT OVERTIGHTEN

**d** M6 BOLT  
20mm LONG

**X 2**

PLEASE NOTE:  
DRILLING REQUIRED  
TO FASTEN TO BUMPER  
DO NOT OVERTIGHTEN

**e** M6 BOLT  
12mm LONG

**X 2**

PLEASE NOTE:  
DRILLING REQUIRED  
TO FASTEN TO BUMPER  
DO NOT OVERTIGHTEN

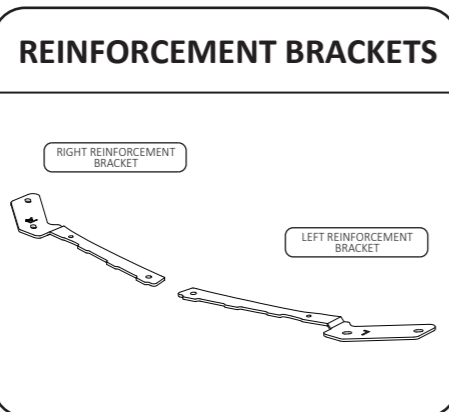
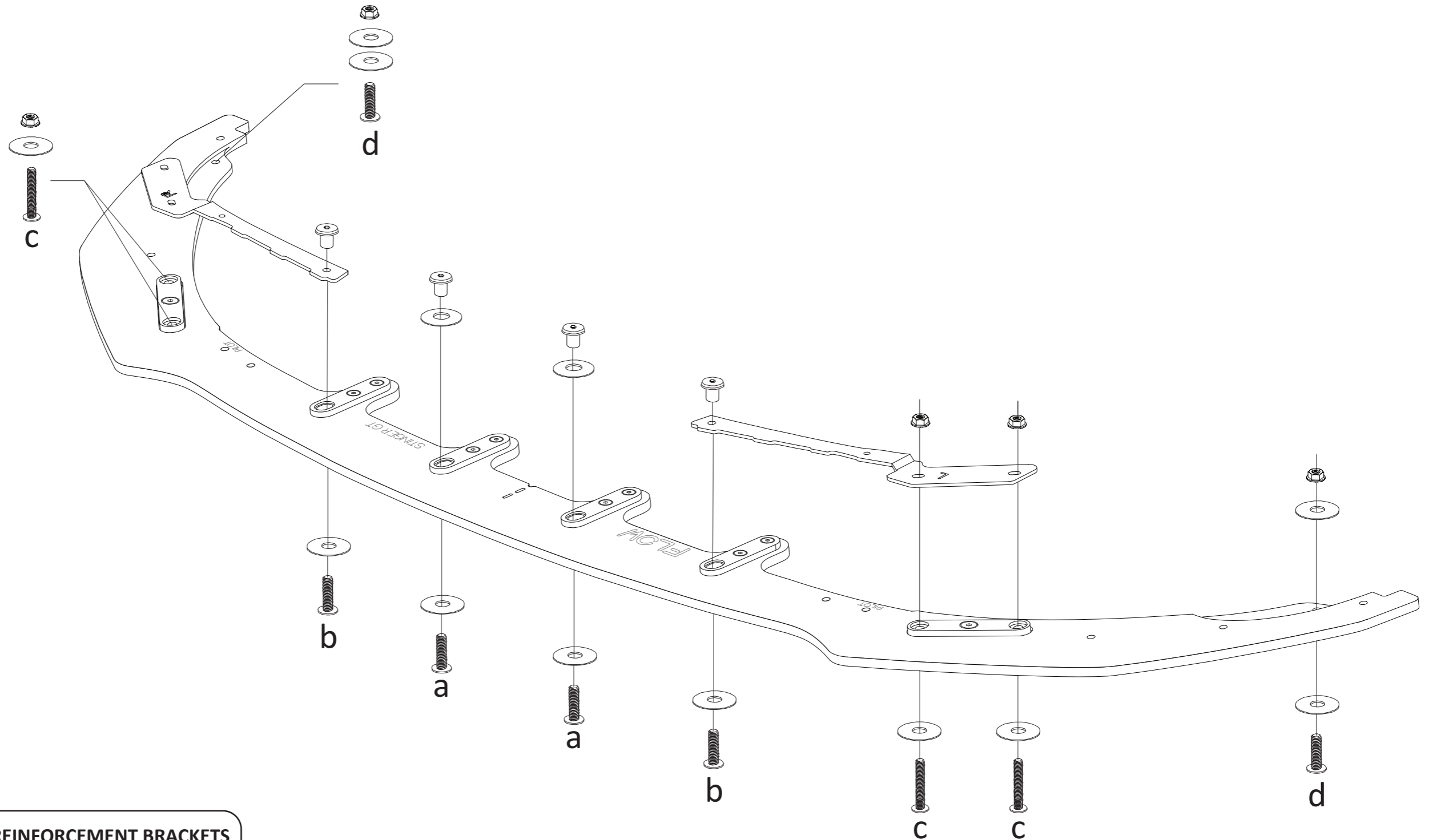

**TERMS AND CONDITIONS : MISUSE OF GOODS**  
 By taking possession of this Flow Designs Australia product, you (the buyer) agree that you have read, understood and will comply with the following disclaimer:  
 This product may not be suitable for road use in your area. We cannot be held liable for any penalties or infringements that may occur as a result of installing any of our products.  
 We cannot guarantee that this product will comply with subsequent government products you have applied to your vehicle. It is not legal to fit parts onto a road registered vehicle unless it carries and meets the design rules and public road regulations of your area, region and/or country.  
 We do make our best effort to consider safety when designing our products, we want the scene to be a safe place for everyone!  
 This disclaimer absolves us (Flow Designs Australia) of any and all liability for breaches to any requirement as a result of installation of our products.

[www.flowdesignsaustralia.com](http://www.flowdesignsaustralia.com)