

# FITTING DIAGRAM

KIA BD CERATO GT PFL HATCH / SEDAN - SIDE WINGLET INSTRUCTIONS

## INSTALLATION AND FITTING SERVICES

If you are having any difficulties please seek professional advice from the listed International and Domestic Authorised Dealers on our website.

[www.flowdesignsaustralia.com](http://www.flowdesignsaustralia.com)

**SIDE SKIRT REMOVAL  
NOT REQUIRED**

## CONFIGURATION 1

FRONT SIDE WINGLETS ONLY

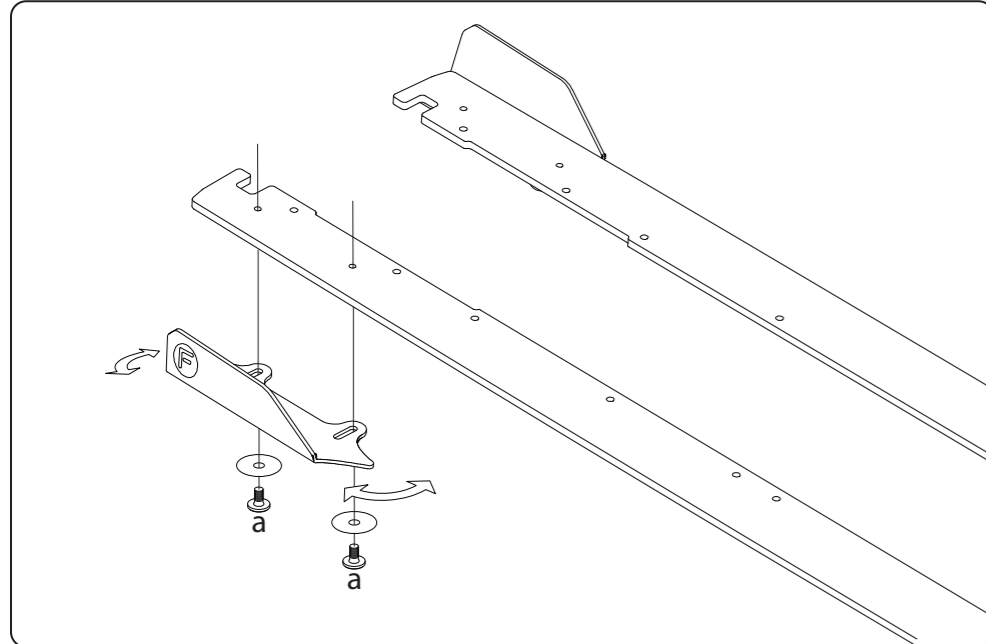

- Insert bolts loosely into allocated brass thread locations.
- Slide extensions in and out to your liking.
- Use a 4mm hex key to hand tighten.

**PLEASE NOTE : DO NOT OVERTIGHTEN** - These bolts do not need to be very tight.

## CONFIGURATION 2

REAR SIDE WINGLETS ONLY

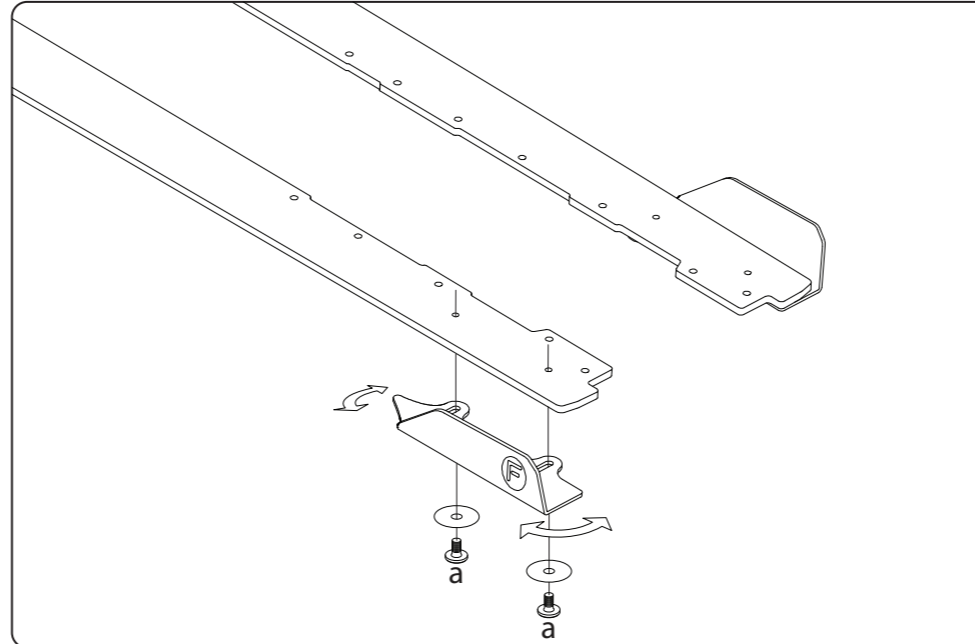

- Insert bolts loosely into allocated brass thread locations.
- Slide and pivot winglets to your liking.
- Use a 4mm hex key to hand tighten.

**PLEASE NOTE : DO NOT OVERTIGHTEN** - These bolts do not need to be very tight.

## CONFIGURATION 3

FRONT AND REAR SIDE WINGLETS

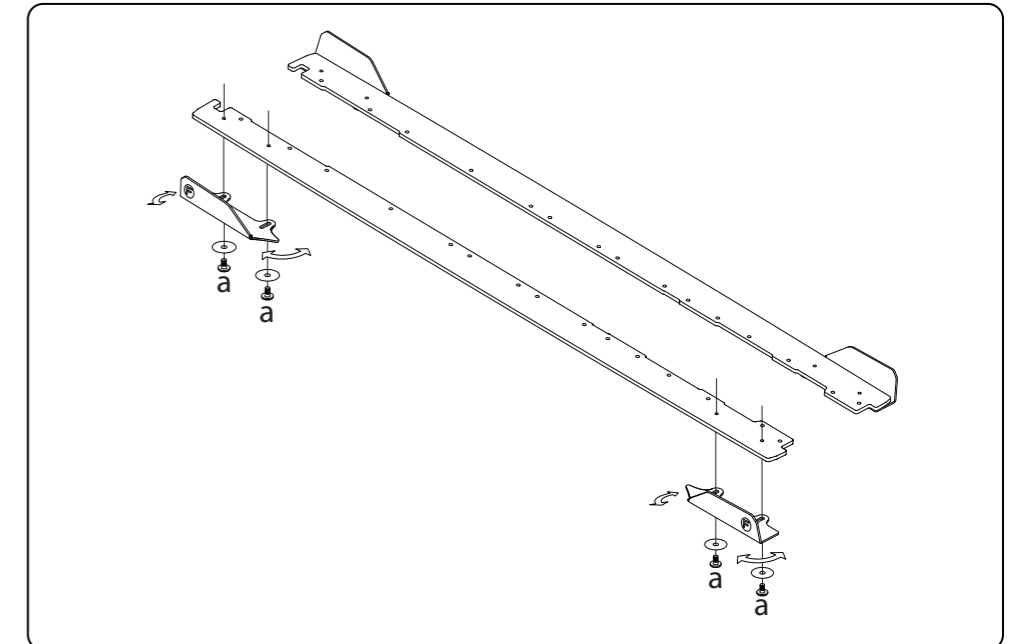

- Insert bolts loosely into allocated brass thread locations.
- Slide and pivot extensions and winglets to your liking.
- Use a 4mm hex key to hand tighten.

**PLEASE NOTE : DO NOT OVERTIGHTEN** - These bolts do not need to be very tight.

## FITTING KIT

a

M6 BOLT  
10mm LONG

**X 4**

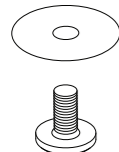

PLEASE NOTE:  
DRILLING NOT REQUIRED  
TO FASTEN TO SPLITTER

**DO NOT OVERTIGHTEN**

**PLEASE NOTE**  
FOR ADD ON ACCESSORIES

**DO NOT**  
OVERTIGHTEN FASTENERS  
INTO BRASS FITTINGS

HAND TIGHTEN ONLY

FLOW  
DESIGNS

**FLOW**  
DESIGNS

FLOW DESIGNS AUSTRALIA  
ABN : 99 605 842 199  
10 LONGSTAFF RD  
BAYSWATER  
VIC, 3153



### TERMS AND CONDITIONS : MISUSE OF GOODS

This Product application is not intended for public road registered vehicles within Australia. Regulations may vary from Countries outside of Australia. Please check your Country's and State's road regulators before installing on a vehicle intended for public road use.

Flow Designs Australia PTY LTD will not be liable for any liabilities in relation to any use of the goods other than in strict accordance with the Company's instructions and for the purpose and application for which the goods were supplied by the Company.

The Client undertakes with the Company:

- That it will acquaint itself with the requirements of all relevant government or statutory and other authorities, bodies or corporations relating to the goods and/or services and to the applications to which the goods and/or services are to be put;
- That at all times while the goods are in its possession or under its control it will comply with such requirements;
- That it will procure that any purchaser of goods from it will also acquaint itself with, and will comply with, such requirements;
- That it will indemnify the Company against any liability resulting from a breach of any such requirements.

[www.flowdesignsaustralia.com](http://www.flowdesignsaustralia.com)