

# FITTING DIAGRAM

HYUNDAI i30N FASTBACK - FACELIFT : REAR DIFFUSER + FLOW-LOCK FINS

INSTALLATION AND FITTING SERVICES

If you are having any difficulties please seek professional advice from the listed International and Domestic Authorised Dealers on our website.

www.flowdesignsaustralia.com

## BUMPER REMOVAL NOT REQUIRED

### HANDY HINTS

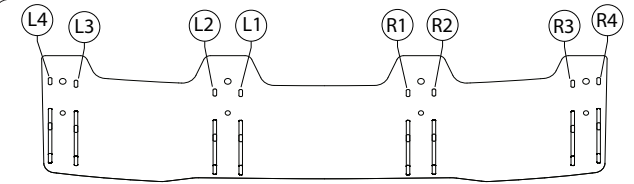

- Align FLOW-LOCK Fins to their corresponding slots.
- Please ensure to allocate the correct FLOW-LOCK Fin to the correct corresponding slot (L1 into L1 slot, R1 into R1 slot etc.)
- Ensure textured side of fin is facing out from opposing fin
- Push fin firmly into the slots until a clicking sound is heard.
- Check both top and bottom locking tabs have securely seated.

**Please Note :** Once fins have been locked into position, they will be difficult to remove.

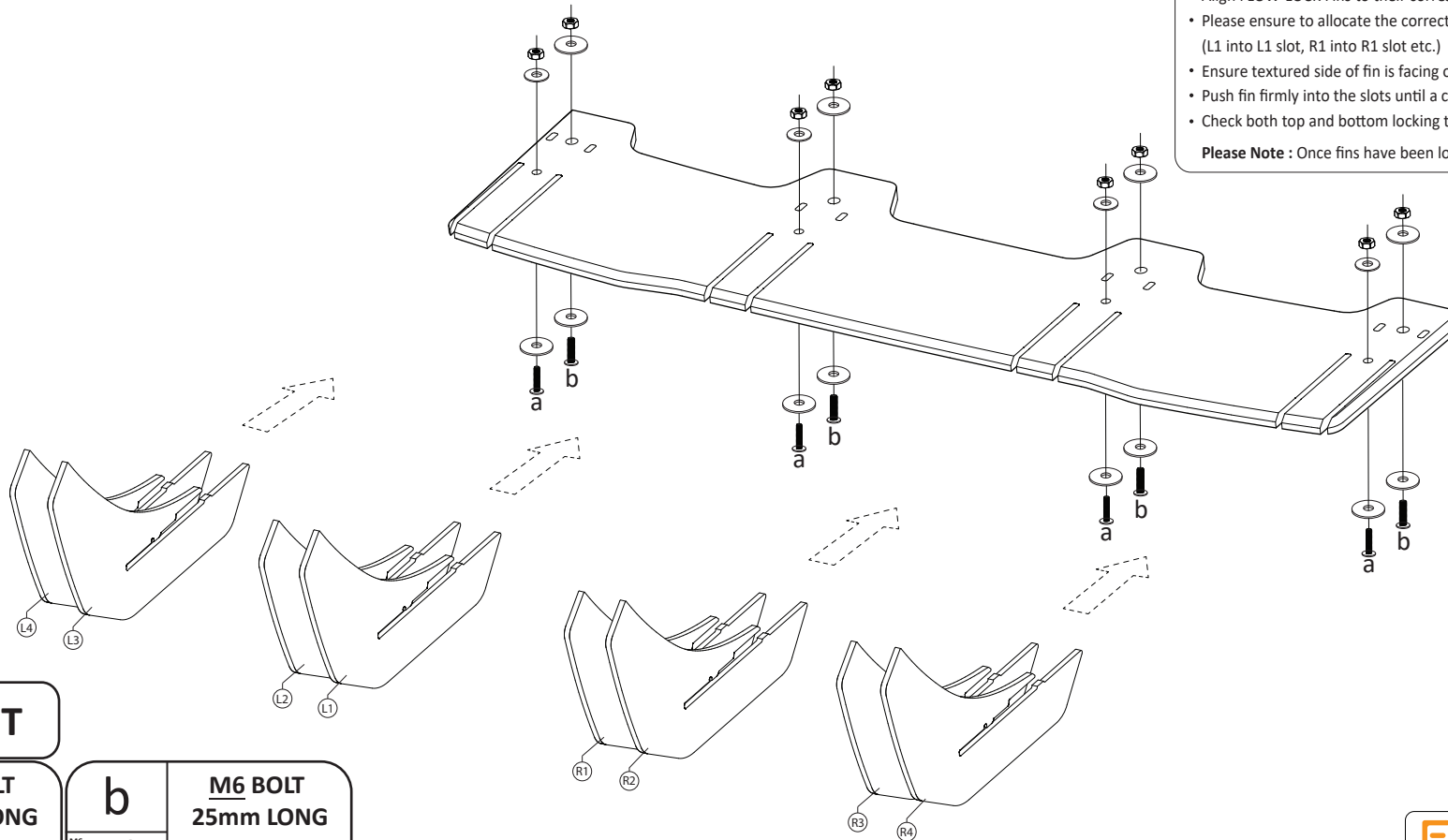

## FITTING KIT

a

**M5 BOLT  
25mm LONG**

**X 4**

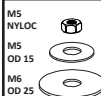

PLEASE NOTE:  
DRILLING REQUIRED  
TO FASTEN TO BUMPER  
PLEASE USE 6mm DRILL BIT

b

**M6 BOLT  
25mm LONG**

**X 4**

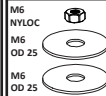

PLEASE NOTE:  
DRILLING REQUIRED  
TO FASTEN TO BUMPER  
PLEASE USE 8mm DRILL BIT

**FLOW**  
DESIGNS

FLOW DESIGNS AUSTRALIA  
ABN: 196 865 342 199  
93 LONGSTAFF RD  
BAYSWATER  
VIC. 3183

DESIGNED AND MANUFACTURED IN AUSTRALIA

**TERMS AND CONDITIONS: MISUSE OF GOODS**  
By having possession of the Flow Designs Australia product, you (the buyer) agree that you have read, understood and will comply with the following disclaimer:

- This product may not be suitable for road use in your area. We cannot be held liable for any penalties or infringements that may occur after installing any of our products.
- We cannot guarantee that this product will comply with all subsequent aftermarket products you have applied to your vehicle.
- It is not legal to fit parts onto a road registered vehicle unless it carries and meets the design rules and public road regulations of your area, region or the country.
- We do our best effort to consider safety when designing our products. We want the scene to be a safe place for everyone!

This disclaimer absolves us (Flow Designs Australia) of any and all liability or breaches to any requirement as a result of installation of our products.

www.flowdesignsaustralia.com

**FLOW-LOCK**  
TECHNOLOGY