

FITTING DIAGRAM

HYUNDAI PD i30N FACELIFT: REAR SPATS + ADJUSTABLE REAR WINGLETS

INSTALLATION AND FITTING SERVICES

If you are having any difficulties please seek professional advice from the listed International and Domestic Authorised Dealers on our website.

www.flowdesignsaustralia.com

BUMPER REMOVAL NOT REQUIRED

HANDY HINT

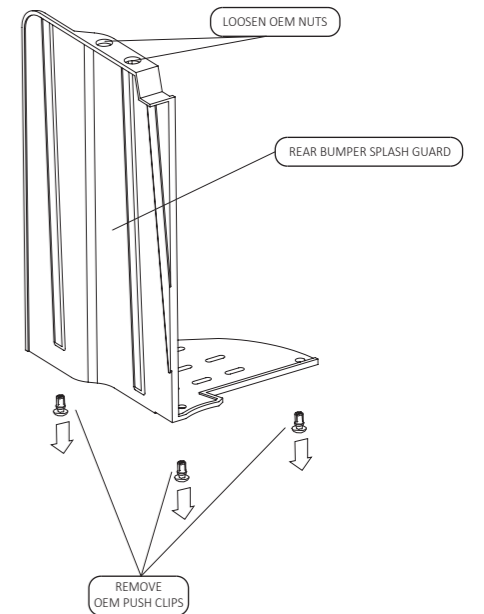

- REMOVE REAR BUMPER SPLASH GUARD BEFORE SPAT INSTALLATION
- TO REMOVE, TAKE OUT OEM PUSH CLIPS AND LOOSEN OEM NUTS

OPTIONAL
ADJUSTABLE REAR SPAT WINGLET
(NOT INCLUDED)

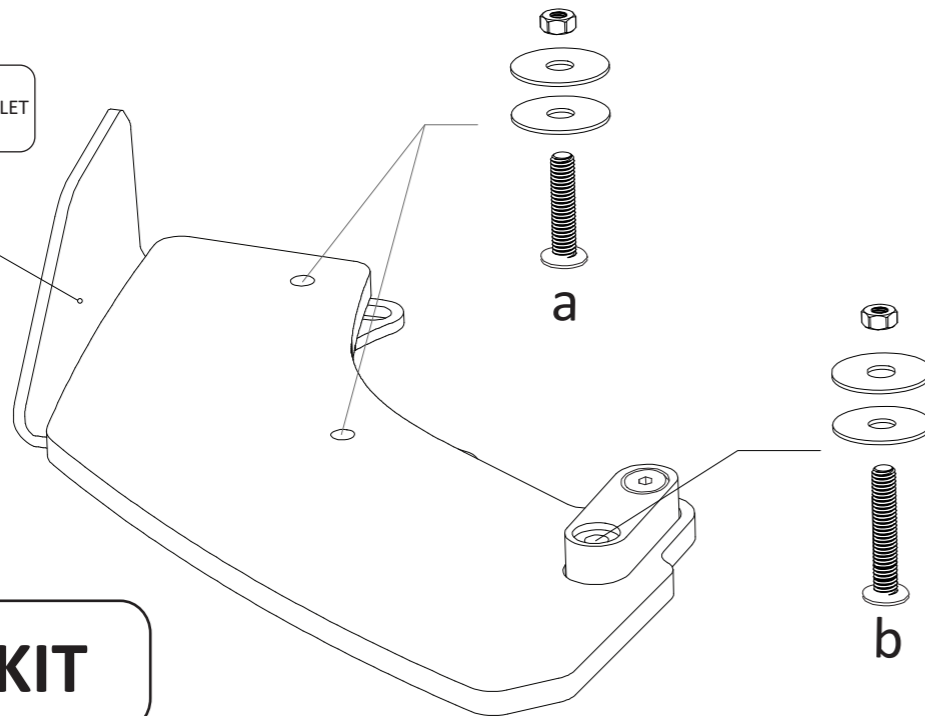

FITTING KIT

a

**M6 BOLT
30mm LONG**

X 4

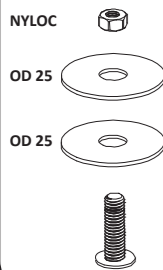

PLEASE NOTE:
DRILLING **REQUIRED**
TO FASTEN TO BUMPER
PLEASE USE 8mm DRILL BIT

b

**M6 BOLT
40mm LONG**

X 2

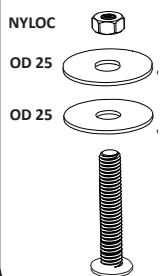

PLEASE NOTE:
DRILLING **REQUIRED**
TO FASTEN TO BUMPER
PLEASE USE 8mm DRILL BIT

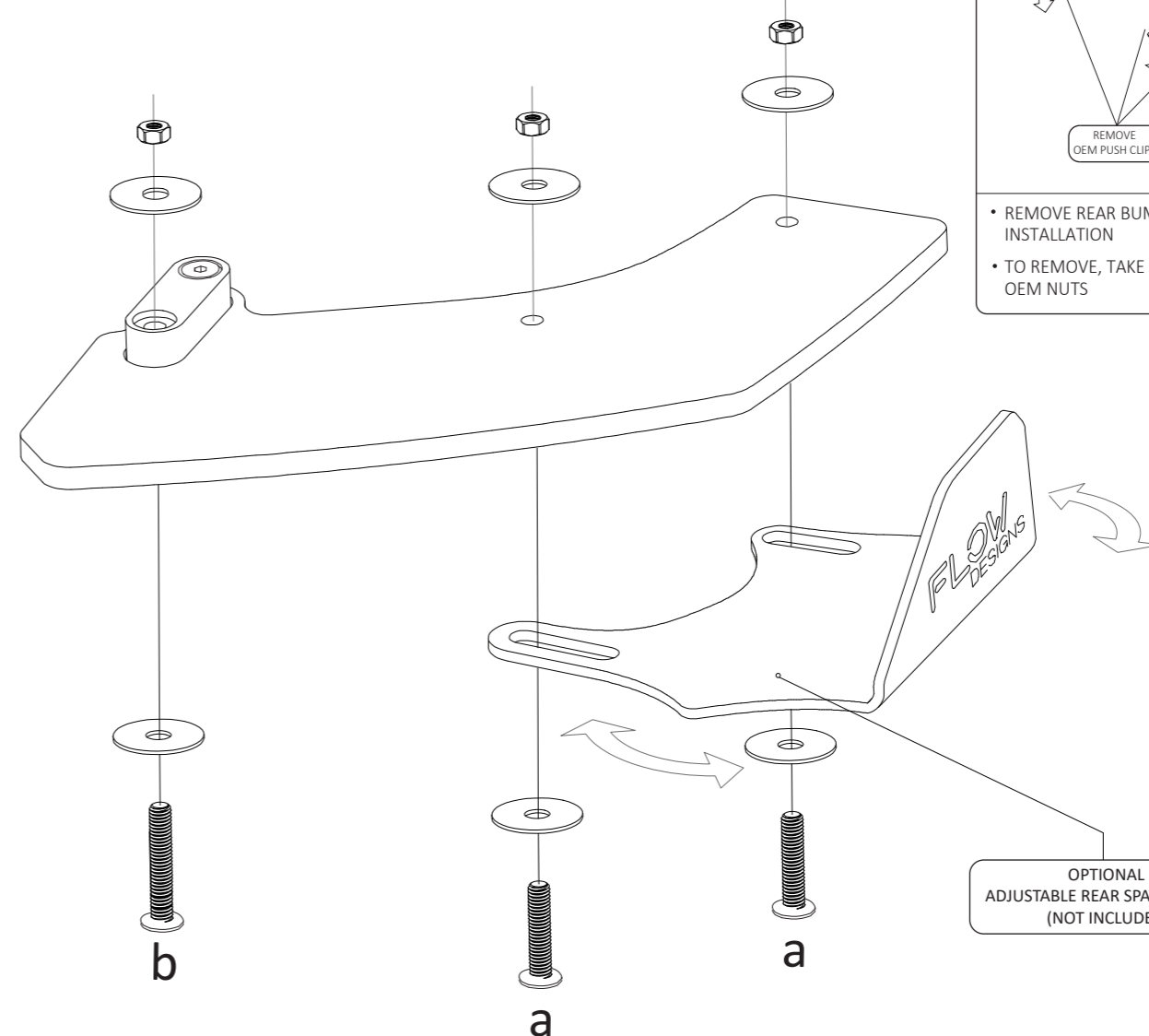

OPTIONAL
ADJUSTABLE REAR SPAT WINGLET
(NOT INCLUDED)