

FITTING DIAGRAM

HYUNDAI SONATA DN8 N-LINE: REAR SPAT INSTRUCTIONS

INSTALLATION AND FITTING SERVICES

If you are having any difficulties please seek professional advice from the listed International and Domestic Authorised Dealers on our website.

www.flowdesignsaustralia.com

**BUMPER REMOVAL
NOT REQUIRED**

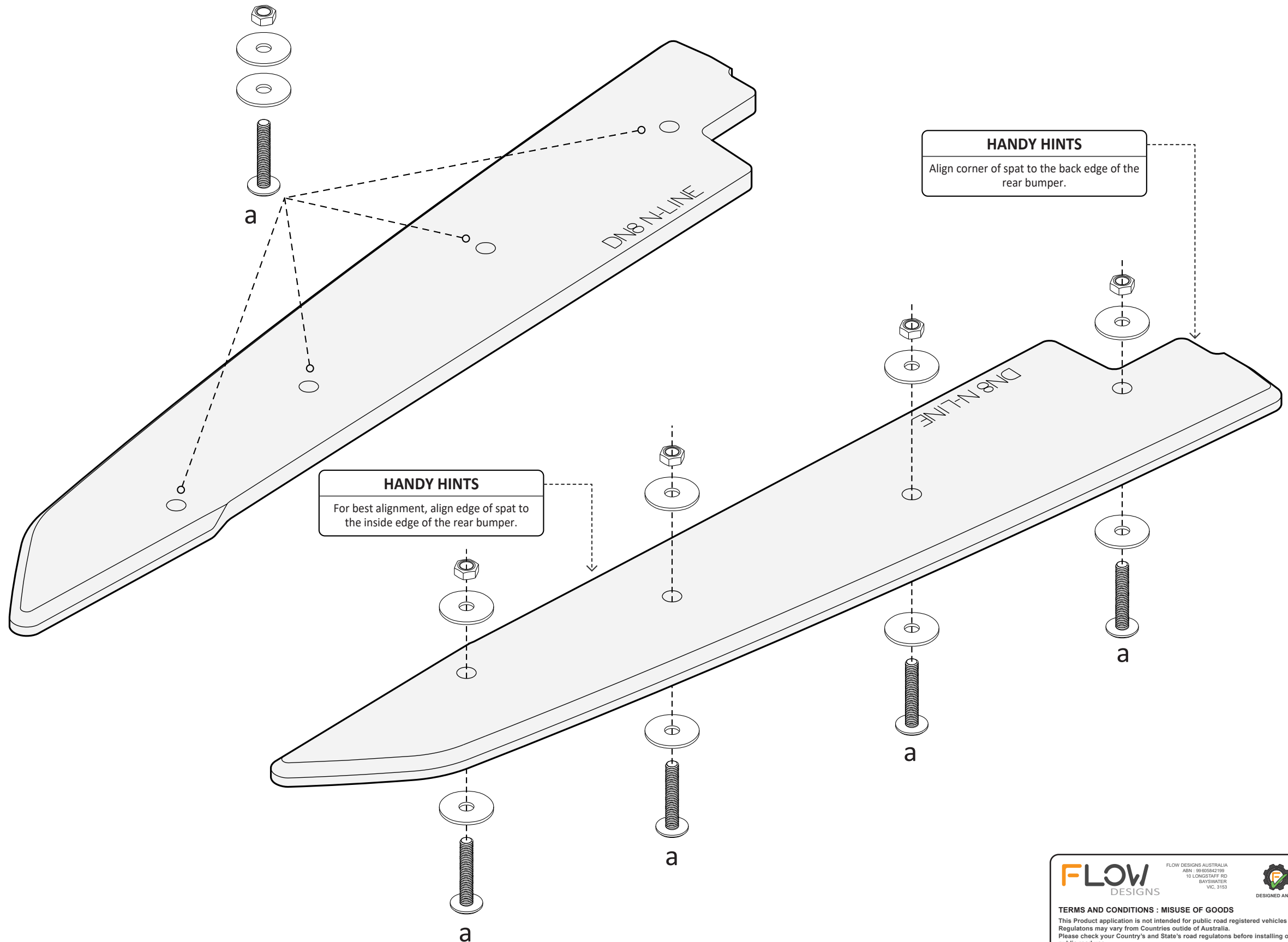

FITTING KIT

a

**M6 BOLT
35mm LONG**

X 8

NYLOC
NUT

OD 25

OD 25

35mm M6

PLEASE NOTE:
**DRILLING REQUIRED
TO FASTEN TO BUMPER
USE AN 8mm DRILL BIT**

FLOW
DESIGNS

FLOW DESIGNS AUSTRALIA
ABN : 99 605842199
10 LONGSTAFF RD
BAYSWATER
VIC. 3153



TERMS AND CONDITIONS : MISUSE OF GOODS

This Product application is not intended for public road registered vehicles within Australia. Regulations may vary from Countries outside of Australia. Please check your Country's and State's road regulations before installing on a vehicle intended for public road use.

Flow Designs Australia PTY LTD will not be liable for any liabilities in relation to any use of the goods other than in strict accordance with the Company's instructions and for the purpose and application for which the goods were supplied by the Company.

The Client undertakes with the Company:

- That it will acquaint itself with the requirements of all relevant government or statutory and other authorities, bodies or corporations relating to the goods and/or services and to the applications to which the goods and/or services are to be put;
- That at all times while the goods are in its possession or under its control it will comply with such requirements;
- That it will procure that any purchaser of goods from it will also acquaint itself with, and will comply with, such requirements;
- That it will indemnify the Company against any liability resulting from a breach of any such requirements.

www.flowdesignsaustralia.com