

HYUNDAI SONATA DN8 N-LINE FRONT SPLITTER INSTRUCTIONS

PLEASE SCAN QR CODE
TO WATCH INSTRUCTIONAL VIDEO
BEFORE INSTALLING

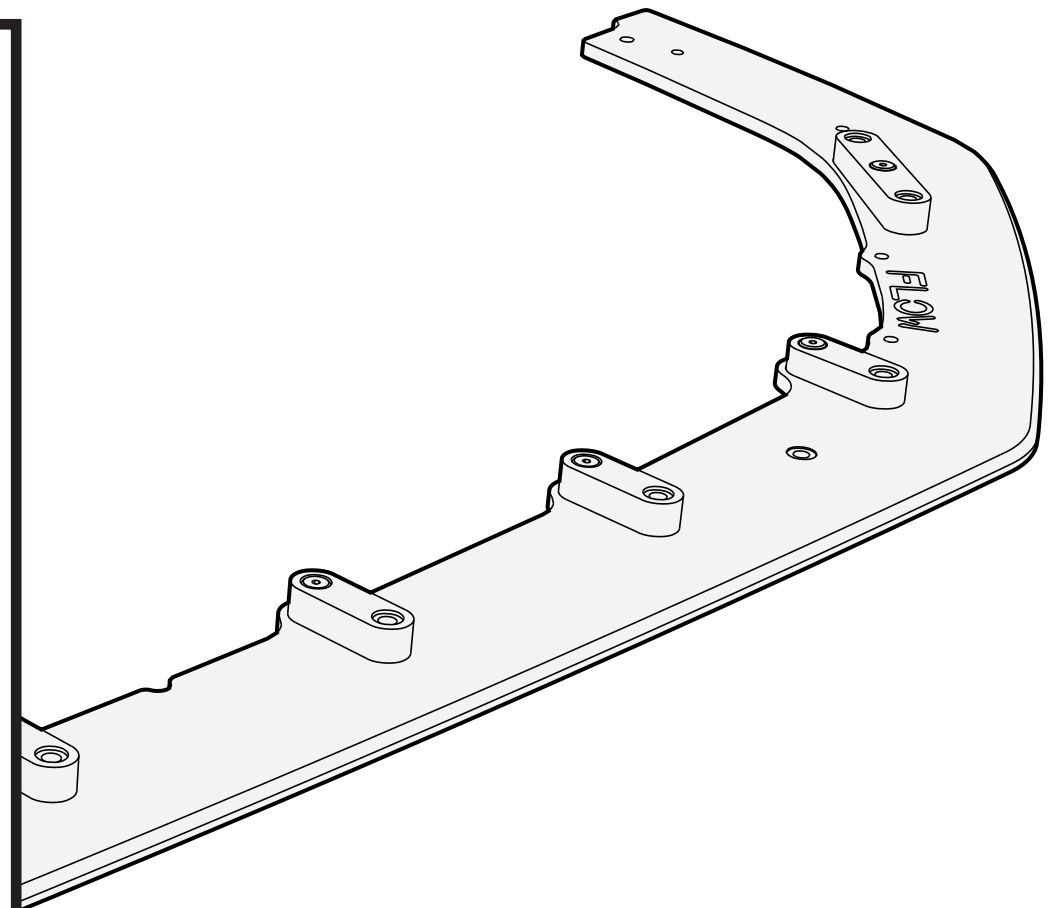
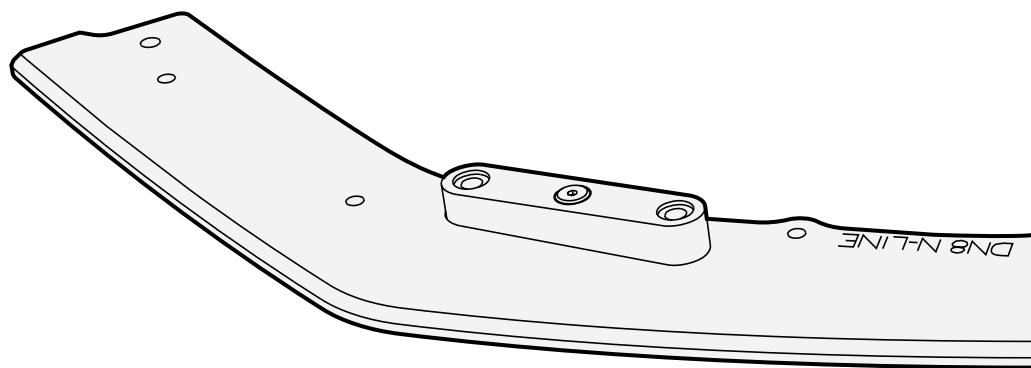
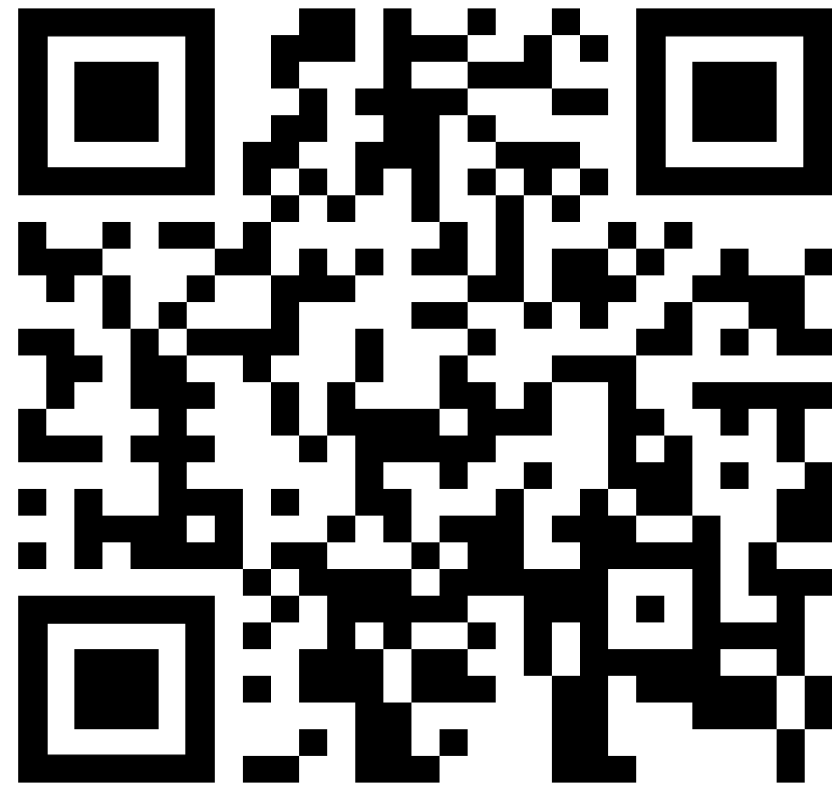

FITTING DIAGRAM

HYUNDAI SONATA DN8 N-LINE: FRONT SPLITTER INSTRUCTIONS

INSTALLATION AND FITTING SERVICES

If you are having any difficulties please seek professional advice from the listed International and Domestic Authorised Dealers on our website.

www.flowdesignsaustralia.com

BUMPER REMOVAL NOT REQUIRED



FLOW DESIGNS AUSTRALIA
ABN : 99 605 842 199
10 LONGSTAFF RD
BAYSWATER
VIC, 3153



TERMS AND CONDITIONS: MISUSE OF GOODS

By taking possession of the Flow Designs Australia product, you (the buyer) agree that you have read, understood and will comply with the following disclaimer:

- This product may not be suitable for road use in your area. We cannot be held liable for any penalties or infringements that may occur after installing any of our products.
- We cannot guarantee that this product will comply with all subsequent aftermarket products you have applied to your vehicle.
- It is not legal to fit parts onto a road registered vehicle unless it carries and meets the designs rules and public road regulations of your area, region and/or country.
- We do our best effort to consider safety when designing our products. We want the scene to be a safe place for everyone!

This disclaimer absolves us (Flow Designs Australia) of any and all liability or breaches to any requirement as a result of installation of our products.

www.flowdesignsaustralia.com

FITTING KIT

a

**M6 BOLT
30mm LONG**

X 2

NYLOC NUT
OD 25
OD 25
30mm M6

PLEASE NOTE:
DRILLING REQUIRED
TO FASTEN TO BUMPER
PLEASE USE 8mm DRILL BIT

b

**M6 BOLT
45mm LONG**

X 4

NYLOC NUT
OD 25
OD 25
45mm M6

PLEASE NOTE:
DRILLING REQUIRED
TO FASTEN TO BUMPER
PLEASE USE 8mm DRILL BIT

c

**M6 BOLT
55mm LONG**

X 6

NYLOC NUT
OD 25
SPACER
OD 25
55mm M6

PLEASE NOTE:
DRILLING REQUIRED
TO FASTEN TO BUMPER
PLEASE USE 8mm DRILL BIT

d

**M6 BOLT
15mm LONG**

X 2

FLANGE NUT
15mm M6

PLEASE NOTE:
DRILLING NOT REQUIRED
TO FASTEN TO BUMPER
REPLACE OEM CLIP

REINFORCEMENT BRACKETS (PAIR)

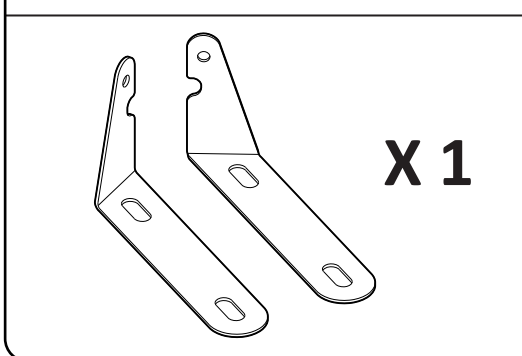

PLEASE NOTE
FOR ADD ON ACCESSORIES

DO NOT
OVERTIGHTEN FASTENERS
INTO BRASS FITTINGS

HAND TIGHTEN ONLY

FLOW DESIGNS

HANDY HINTS

Align corner and inside of splitter to back edge of bumper before drilling for best fitment.

FITTING KIT - C INSTALLATION GUIDE

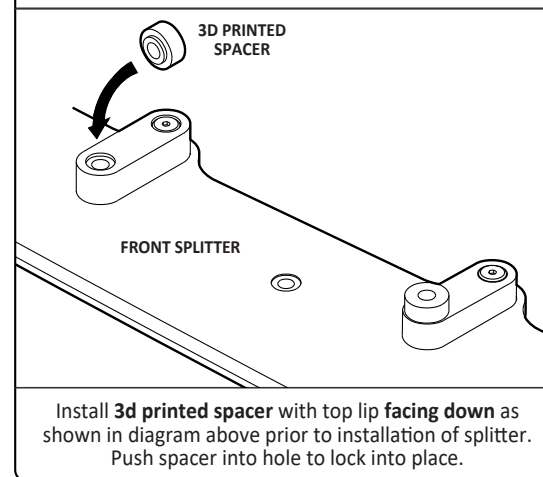

HANDY HINTS

Remove undertray prior to installation of front splitter. Reinstall undertray after installation of splitter.

REINFORCEMENT BRACKET INSTALLATION GUIDE

Use Phillips head screwdriver to remove OEM screw within bumper. Drill mounting holes (b) then align reinforcement bracket with holes.

Loosely thread bolts through bracket before securing bracket with OEM screw. Tighten mounting bolts to reinforcement bracket.

REFER TO INSTALLATION VIDEO

REINFORCEMENT BOLTS - D INSTALLATION GUIDE

Remove OEM clips within guard liner to access OEM clip to be replaced. Remove OEM clip that attaches to the bumper and lower lip and replace with supplied fitting kit (d). Tighten bolt and reinstall remaining OEM clips to guard liner.

REFER TO INSTALLATION VIDEO

INSTRUCTIONAL VIDEO QR CODE

