

# HYUNDAI CN7 N REAR DIFFUSER INSTRUCTIONS

*i30N SEDAN / ELANTRA N*

PLEASE SCAN QR CODE  
TO WATCH INSTRUCTIONAL VIDEO  
BEFORE INSTALLING

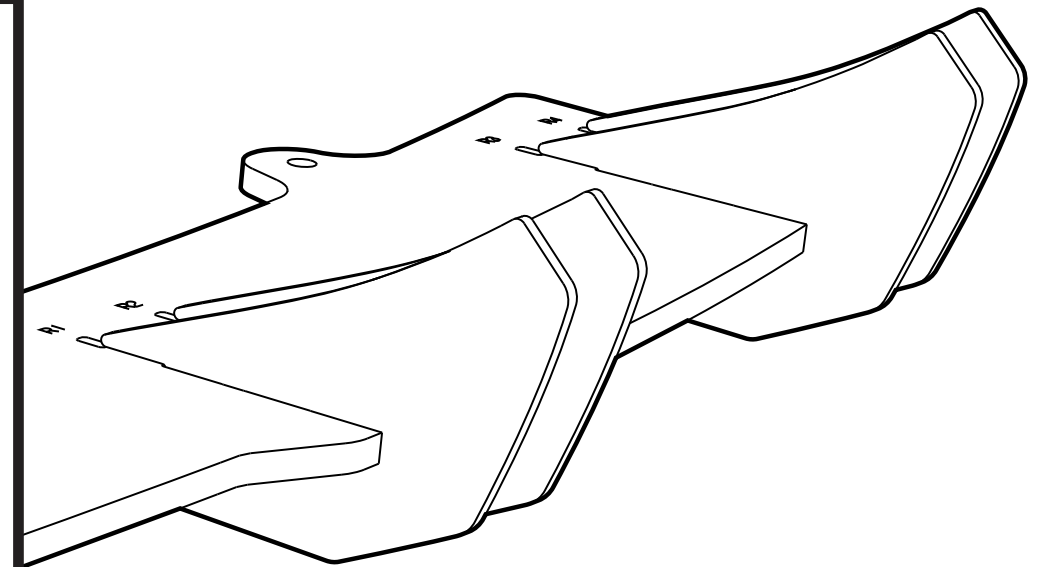
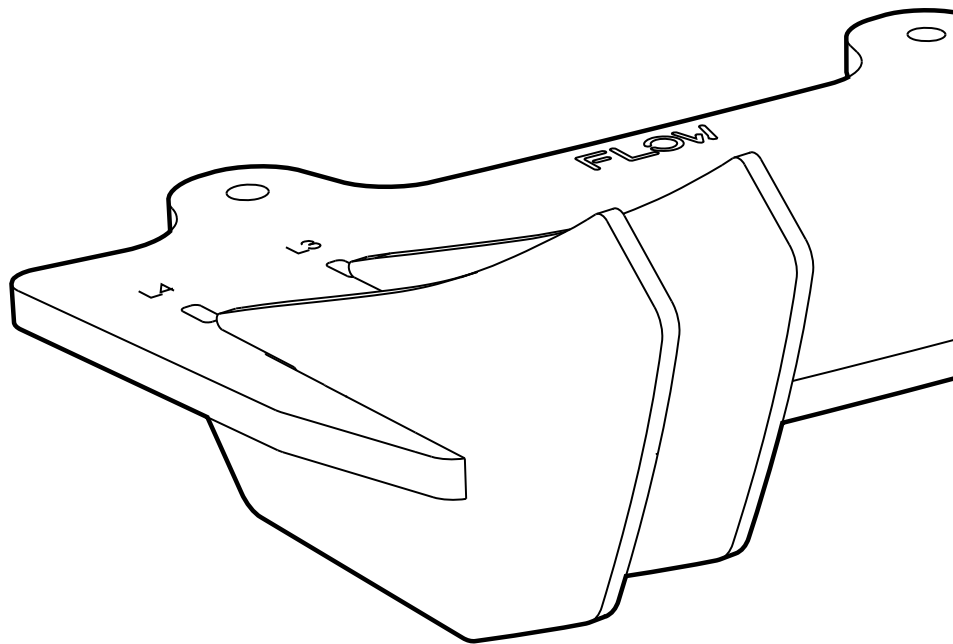
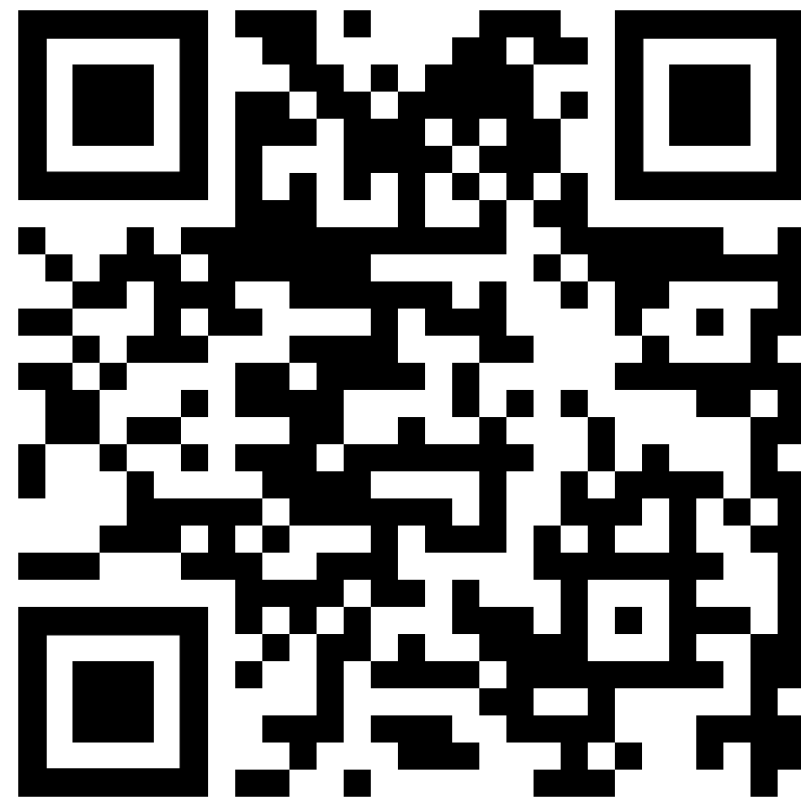

# FITTING GUIDE - PAGE 2

## HYUNDAI CN7 N: REAR DIFFUSER + FLOW LOCK FINS INSTRUCTIONS

### INSTALLATION AND FITTING SERVICES

If you are having any difficulties please seek professional advice from the listed International and Domestic Authorised Dealers on our website.

www.flowdesignsaustralia.com

# BUMPER REMOVAL NOT REQUIRED

### HANDY HINTS

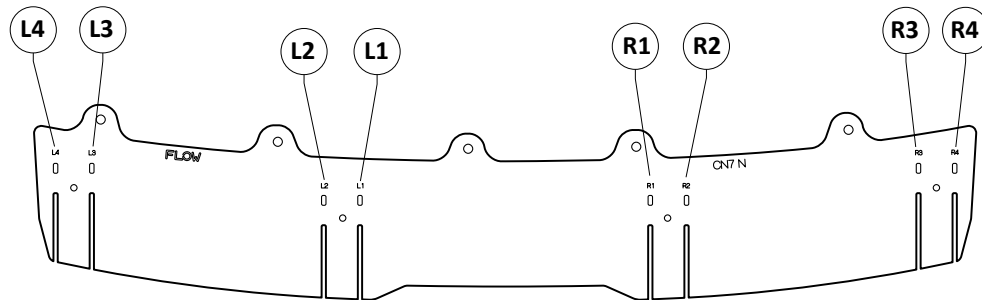

- Align FLOW-LOCK Fins to their corresponding slots.
- Please ensure to allocate the correct FLOW-LOCK Fin to the correct corresponding slot (L1 into L1 slot, R1 into R1 slot etc.)
- Ensure textured side of fin is facing out from opposing fin
- Push fin in firmly into the slots until a clicking sound is heard.
- Check both top and bottom locking tabs have securely seated

**Please Note:** Once fins have been locked into position, they will be difficult to remove.

### HANDY HINT - JACK NUT INSTALLATION

#### STEP A

Ensure to insert Jack nut into Pre-drilled hole in OEM rear bumper before compressing

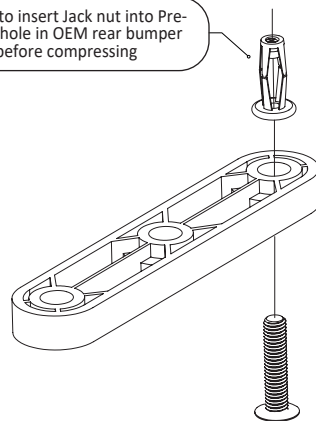

#### STEP B

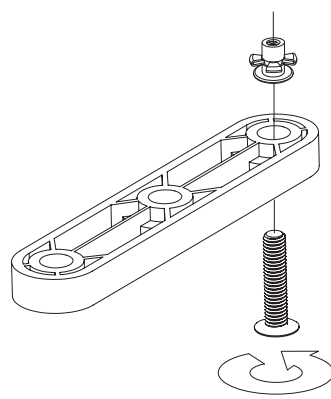

- Using provided Flow Designs Jack Nut Compression Tool, install provided jack nuts into the drilled out holes in the rear bumper
- Please ensure that the Jack Nut is firmly inserted into pre-drilled holes in enlarged hole.
- Tighten supplied bolt through Jack Nut Compression Tool until Jack Nut is fully compressed.

### INSTALLATION DIAGRAM - FITTING KIT A

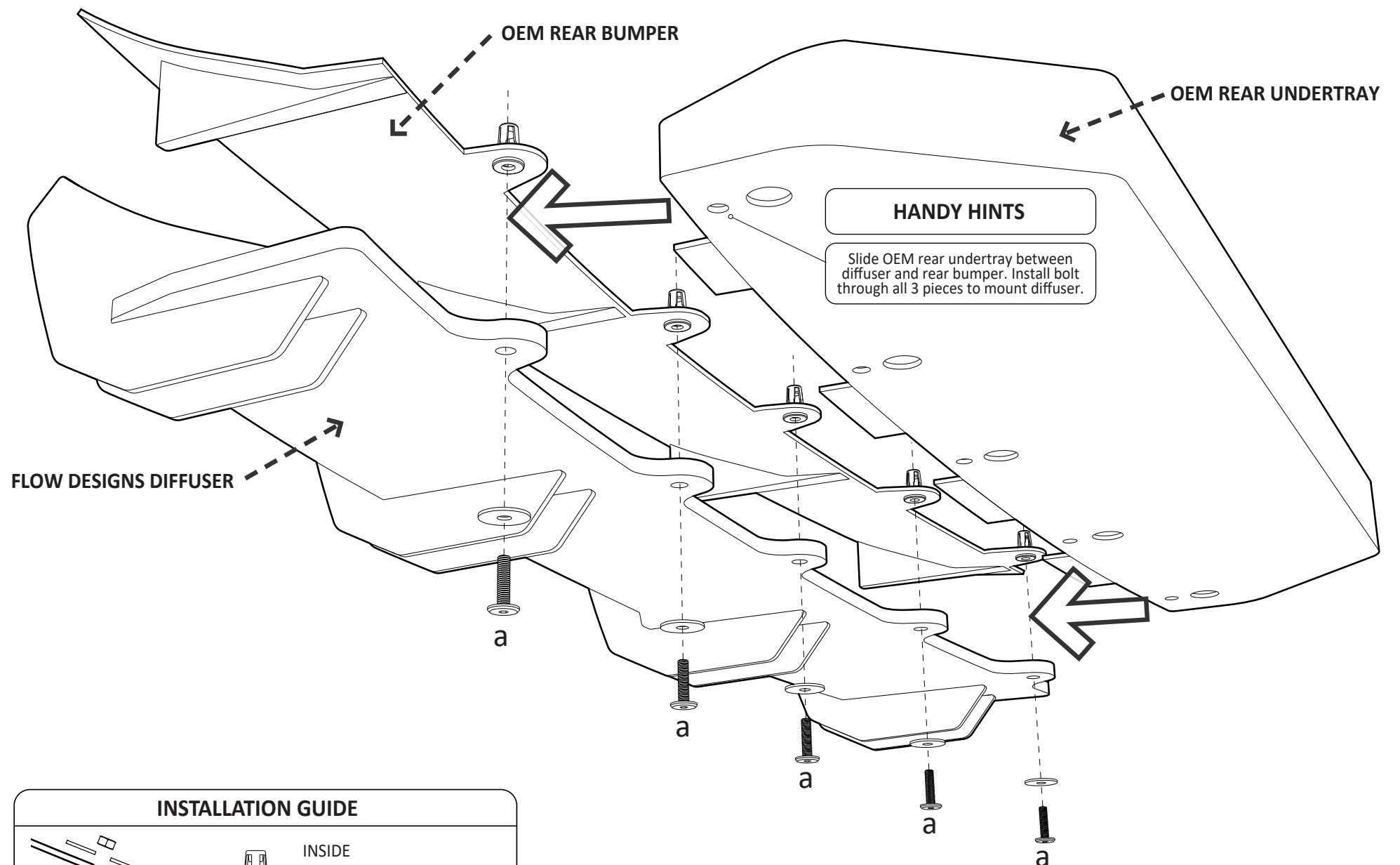

### INSTALLATION GUIDE

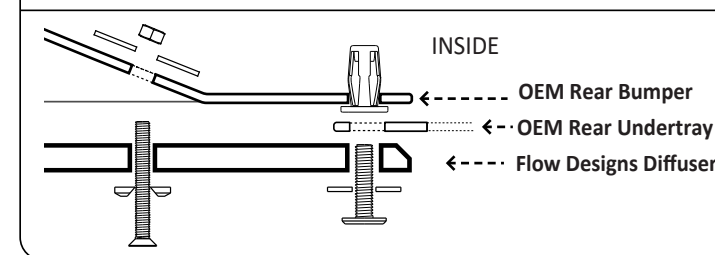

**LOW-LOG**  
TECHNOLOGY

**FLOW**  
DESIGNS

FLOW DESIGNS AUSTRALIA  
ABN : 99 605 842 199  
10 LONGSTAFF RD  
BAYSWATER  
VIC, 3153



#### TERMS AND CONDITIONS: MISUSE OF GOODS

By taking possession of the Flow Designs Australia product, you (the buyer) agree that you have read, understood and will comply with the following disclaimer:

- This product may not be suitable for road use in your area. We cannot be held liable for any penalties or infringements that may occur after installing any of our products.
- We cannot guarantee that this product will comply with all subsequent aftermarket products you have applied to your vehicle.
- It is not legal to fit parts onto a road registered vehicle unless it carries and meets the design rules and public road regulations of your area, region and/or country.
- We do our best effort to consider safety when designing our products. We want the scene to be a safe place for everyone!

This disclaimer absolves us (Flow Designs Australia) of any and all liability or breaches to any requirement as a result of installation of our products.

www.flowdesignsaustralia.com

# FITTING DIAGRAM - PAGE 1

HYUNDAI CN7 N: REAR DIFFUSER + FLOW LOCK FINS INSTRUCTIONS

## INSTALLATION AND FITTING SERVICES

If you are having any difficulties please seek professional advice from the listed International and Domestic Authorised Dealers on our website.

www.flowdesignsaustralia.com

# BUMPER REMOVAL NOT REQUIRED

## INSTALLATION GUIDE

- Remove existing rear undertray.
- Enlarge OEM holes with 11mm bit (*no larger than 11mm*) and install Jack Nuts (a).
- For best fitment, temporarily mount the diffuser using bolts (a) prior to drilling holes for (b).
- Align and centre the holes for (b) to OEM fins on rear bumper then drill.
- Using bolts (b) mount diffuser to rear bumper, then remove bolts (a) to reinstall undertray.
- Insert OEM undertray inbetween diffuser and rear bumper, then reinstall and tighten bolts (a).
- Lastly install diffuser fins into corresponding slots.

SCAN QR CODE TO WATCH INSTALLATION VIDEO PRIOR TO INSTALLING

## INSTRUCTIONAL VIDEO QR CODE

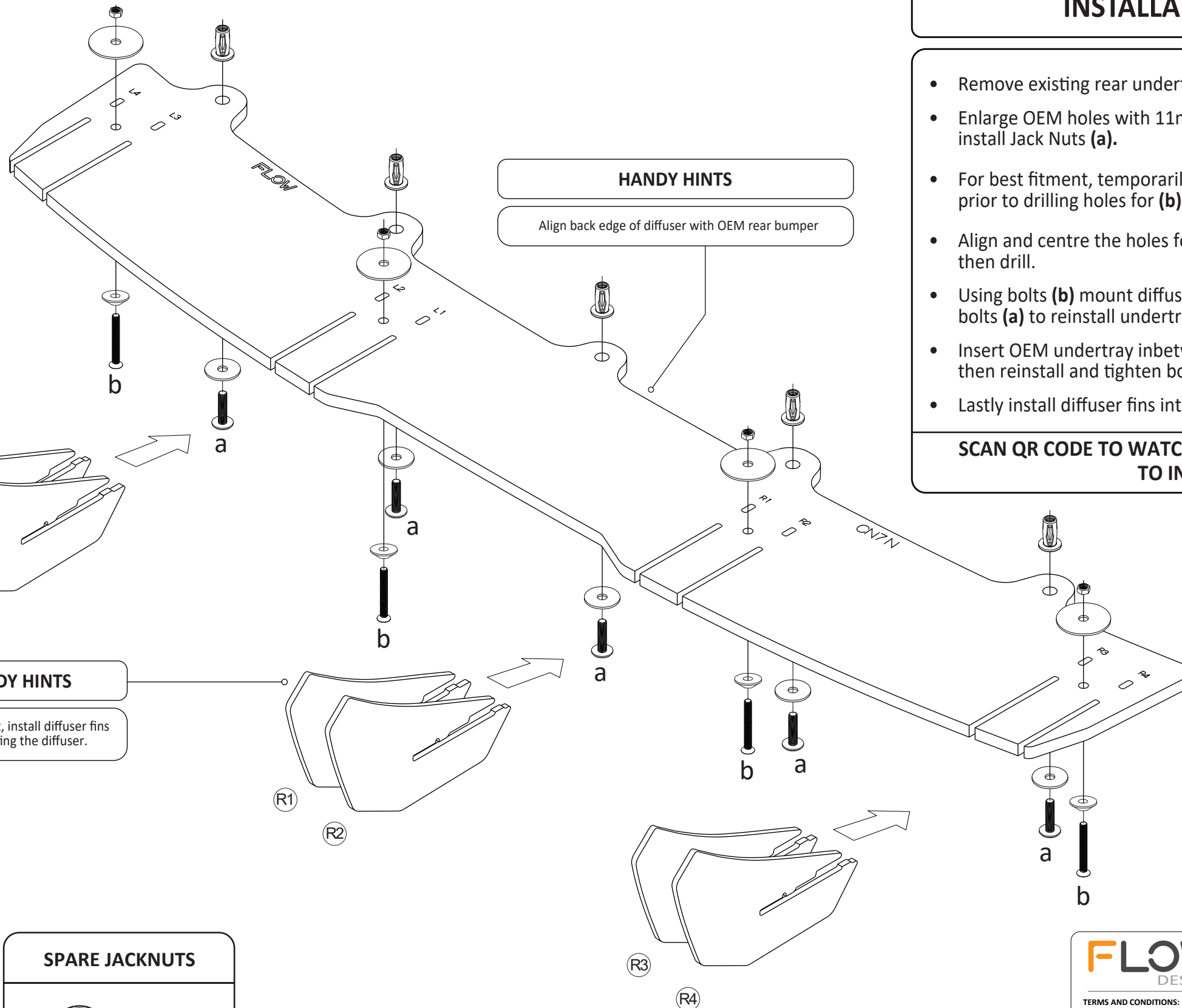

### HANDY HINTS

Align back edge of diffuser with OEM rear bumper

### HANDY HINTS

For best fitment, install diffuser fins after mounting the diffuser.

## FITTING KIT

**a** M6 BOLT 25mm LONG

**X 5**

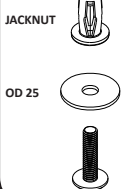

PLEASE NOTE:  
DRILLING REQUIRED TO FASTEN TO BUMPER  
DO NOT OVERTIGHTEN  
PLEASE USE 11mm DRILL BIT

**b** M5 BOLT 40mm LONG

**X 4**



PLEASE NOTE:  
DRILLING REQUIRED TO FASTEN TO BUMPER  
DO NOT OVERTIGHTEN  
PLEASE USE 6mm DRILL BIT

### JACKNUT COMPRESSION TOOL

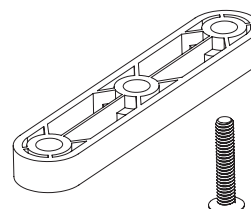

3 HOLE AEROSPACER x 1

30mm BOLT x 1

### SPARE JACKNUTS

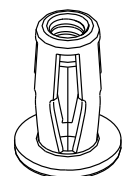

**X 2**

**FLOW-LOG**  
TECHNOLOGY

**FLOW**  
DESIGNS

FLOW DESIGNS AUSTRALIA  
ABN : 99 605 842 199  
10 LONGSTAFF RD  
BAYSWATER  
VIC. 3153



### TERMS AND CONDITIONS: MISUSE OF GOODS

By taking possession of the Flow Designs Australia product, you (the buyer) agree that you have read, understood and will comply with the following disclaimer:

- This product may not be suitable for road use in your area. We cannot be held liable for any penalties or infringements that may occur after installing any of our products.
- We cannot guarantee that this product will comply with all subsequent aftermarket products you have applied to your vehicle.
- It is not legal to fit parts onto a road registered vehicle unless it carries and meets the design rules and public road regulations of your area, region and/or country.
- We do our best effort to consider safety when designing our products. We want the scene to be a safe place for everyone!

This disclaimer absolves us (Flow Designs Australia) of any and all liability or breaches to any requirement as a result of installation of our products.

www.flowdesignsaustralia.com