

FITTING DIAGRAM

HONDA FK8 CIVIC TYPE R- FRONT BOLT-ON INSTRUCTIONS

INSTALLATION AND FITTING SERVICES

If you are having any difficulties please seek professional advice from the listed International and Domestic Authorised Dealers on our website.

www.flowdesignsaustralia.com

**BUMPER REMOVAL
NOT REQUIRED**

CONFIGURATION 1

FRONT EXTENSIONS ONLY

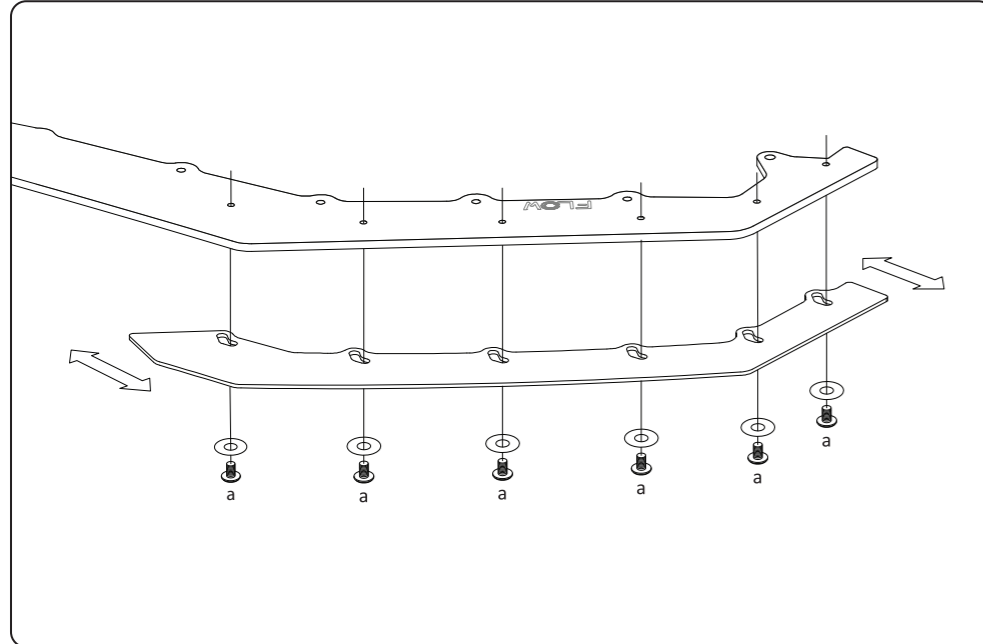

- Insert bolts loosely into allocated brass thread locations.
- Slide extensions in and out to your liking.
- Use a 4mm hex key to hand tighten.

PLEASE NOTE : DO NOT OVERTIGHTEN - These bolts do not need to be very tight.

CONFIGURATION 2

FRONT WINGLETS ONLY

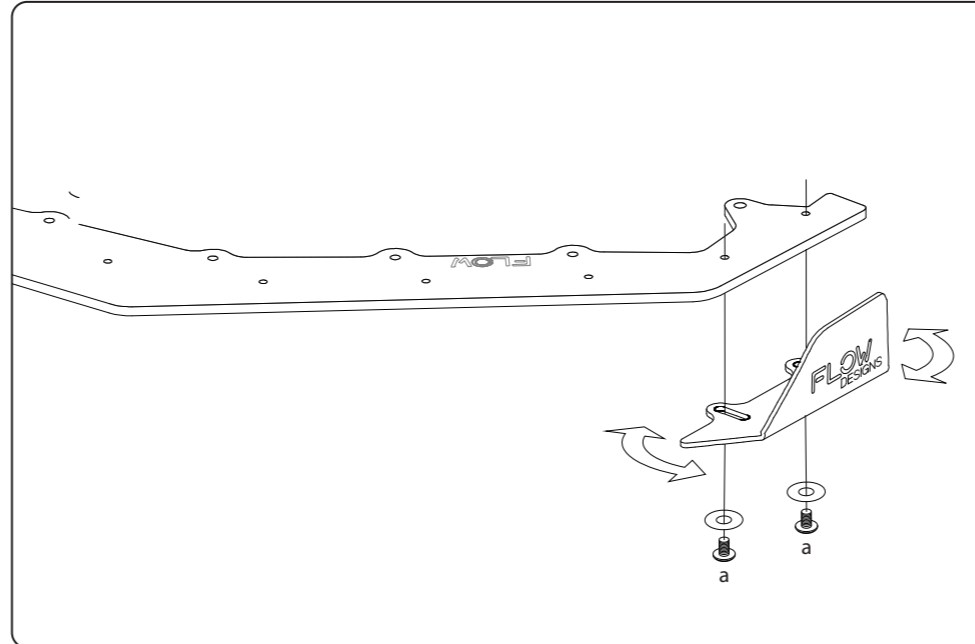

- Insert bolts loosely into allocated brass thread locations.
- Slide and pivot winglets to your liking.
- Use a 4mm hex key to hand tighten.

PLEASE NOTE : DO NOT OVERTIGHTEN - These bolts do not need to be very tight.

CONFIGURATION 3

FRONT EXTENSIONS AND WINGLETS

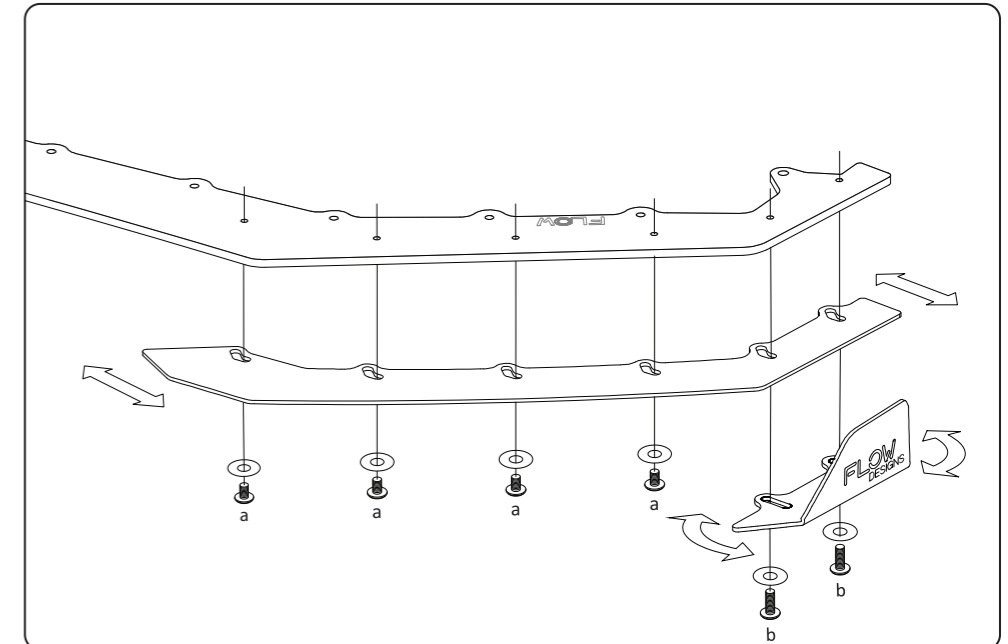

- Insert bolts loosely into allocated brass thread locations.
- Slide and pivot extensions and winglets to your liking.
- Use a 4mm hex key to hand tighten.

PLEASE NOTE : DO NOT OVERTIGHTEN - These bolts do not need to be very tight.

FITTING KIT

a

M6 BOLT
12mm LONG

X 12

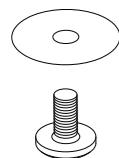

PLEASE NOTE:
DRILLING NOT REQUIRED
TO FASTEN TO SPLITTER

DO NOT OVERTIGHTEN

b

M6 BOLT
20mm LONG

X 4

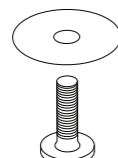

PLEASE NOTE:
DRILLING NOT REQUIRED
TO FASTEN TO SPLITTER

DO NOT OVERTIGHTEN

PLEASE NOTE
FOR ADD ON ACCESSORIES

DO NOT
OVERTIGHTEN FASTENERS
INTO BRASS FITTINGS

HAND TIGHTEN ONLY

FLOW
DESIGNS

FLOW
DESIGNS

FLOW DESIGNS AUSTRALIA
ABN : 99 605 942 199
FACTORY 11
6-7 NICOLE CLOSE
BAYSWATER NORTH
VIC. 3153

DESIGNED AND MANUFACTURED IN AUSTRALIA

TERMS AND CONDITIONS : MISUSE OF GOODS

This Product application is not intended for public road registered vehicles within Australia. Regulations may vary from Countries outside of Australia. Please check your Country's and State's road regulations before installing on a vehicle intended for public road use.

Flow Designs Australia PTY LTD will not be liable for any liabilities in relation to any use of the goods other than in strict accordance with the Company's instructions and for the purpose and application for which the goods were supplied by the Company.

The Client undertakes with the Company:

- That it will acquaint itself with the requirements of all relevant government or statutory and other authorities, bodies or corporations relating to the goods and/or services and to the applications to which the goods and/or services are to be put;
- That at all times while the goods are in its possession or under its control it will comply with such requirements;
- That it will procure that any purchaser of goods from it will also acquaint itself with, and will comply with, such requirements;
- That it will indemnify the Company against any liability resulting from a breach of any such requirements.

www.flowdesignsaustralia.com