

FITTING GUIDE

HONDA ACCORD CU2 PFL/FL: SIDE SPLITTER INSTRUCTIONS

INSTALLATION GUIDE

1. Clean underside surface of side sill.
2. Remove rubber grommet plugs from underside of sill and clips at front of side skirt.
3. Align the drilling template to the rubber grommet holes and clamp to front and rear of metal sill as shown in **Diagram A**.
4. Hold template through rubber grommet holes to mark each hole on drilling template.
5. Drill marked holes through metal sill with Step Drill to 9mm bit or 9mm drill bit as shown in **Diagram B**.
6. Apply adhesive sealant on nutsert around flange as show in **Diagram C**.
7. Compress nutsert into drilled holes as shown in **Diagram D**.
8. Align side splitter to side skirt and mount supplied bolts into nutsert to complete installation.
9. Reinstall rubber grommet plugs and clips.

INSTALLATION AND FITTING SERVICES

If you are having any difficulties please seek professional advice from the listed International and Domestic Authorised Dealers on our website.

www.flowdesignsaustralia.com

DRILLING INTO METAL SIDE SILL REQUIRED

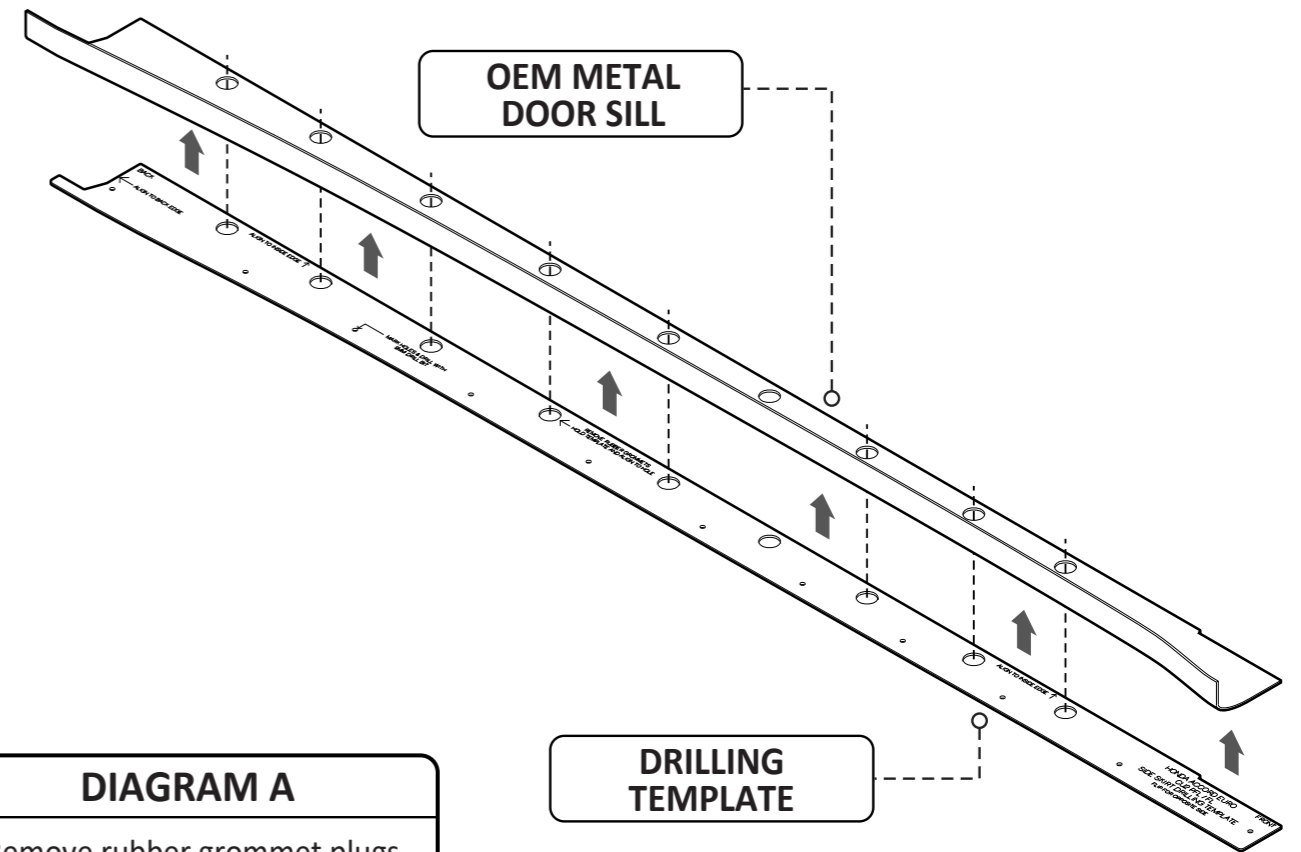

DIAGRAM A

Remove rubber grommet plugs and align template to holes.

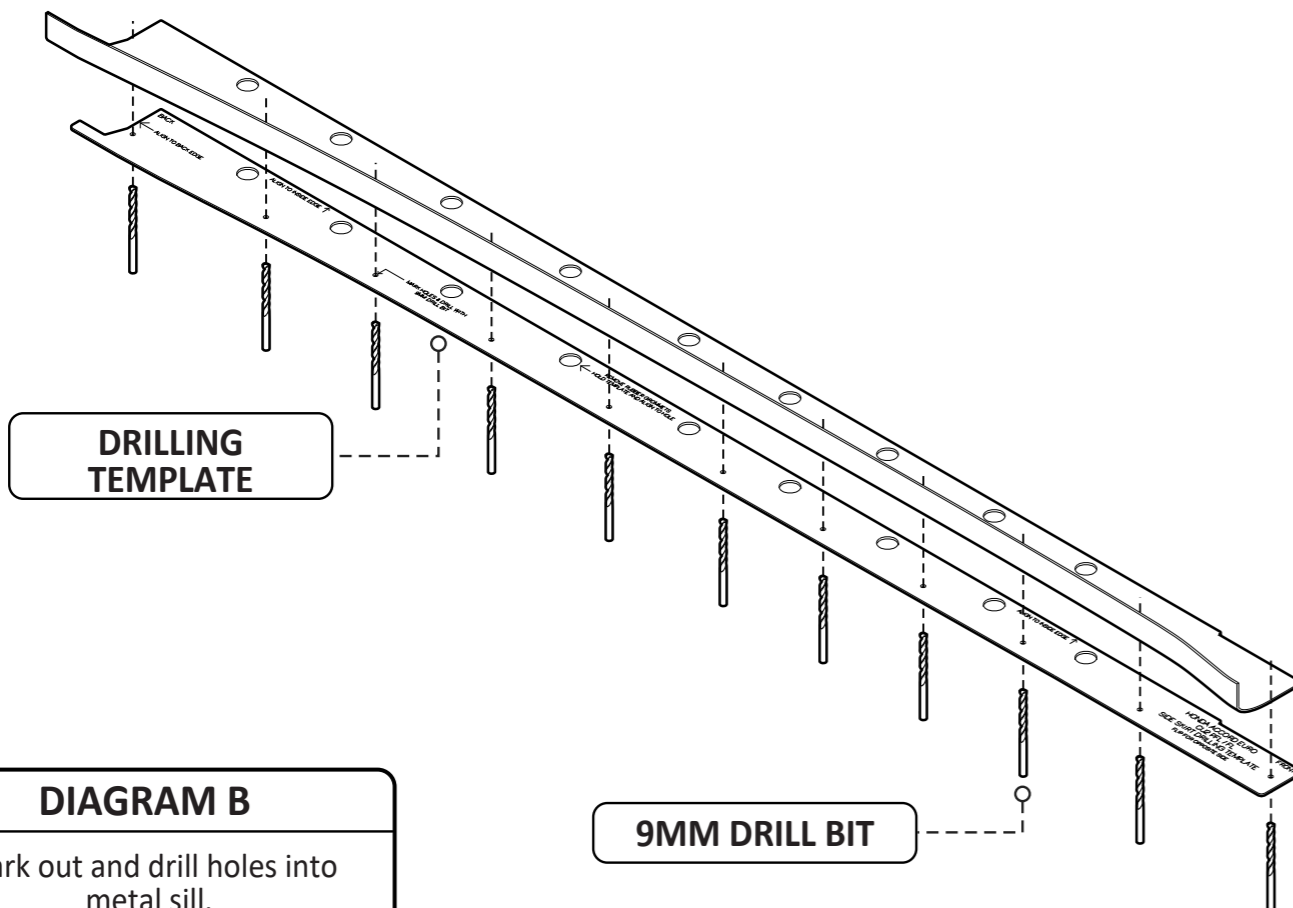

DIAGRAM B

Mark out and drill holes into metal sill.

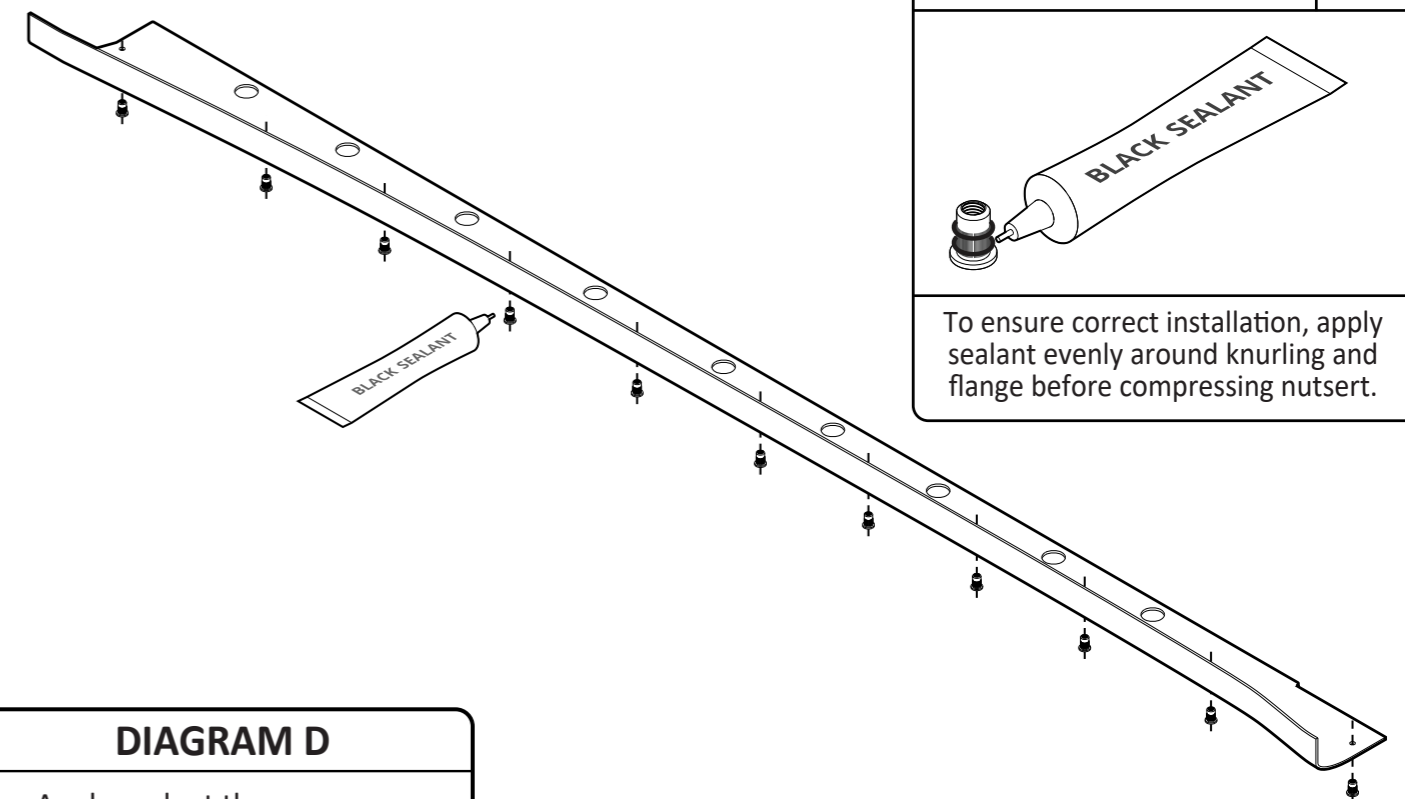

DIAGRAM D

Apply sealant then compress nutserts into metal sill.

FITTING DIAGRAM

HONDA ACCORD CU2 PFL/FL: SIDE SPLITTER INSTRUCTIONS

INSTALLATION AND FITTING SERVICES

If you are having any difficulties please seek professional advice from the listed International and Domestic Authorised Dealers on our website.

www.flowdesignsaustralia.com

**DRILLING INTO METAL
SIDE SILL REQUIRED**

REAR

HANDY HINTS

Align back edge of side splitter with rear underside of the metal body.

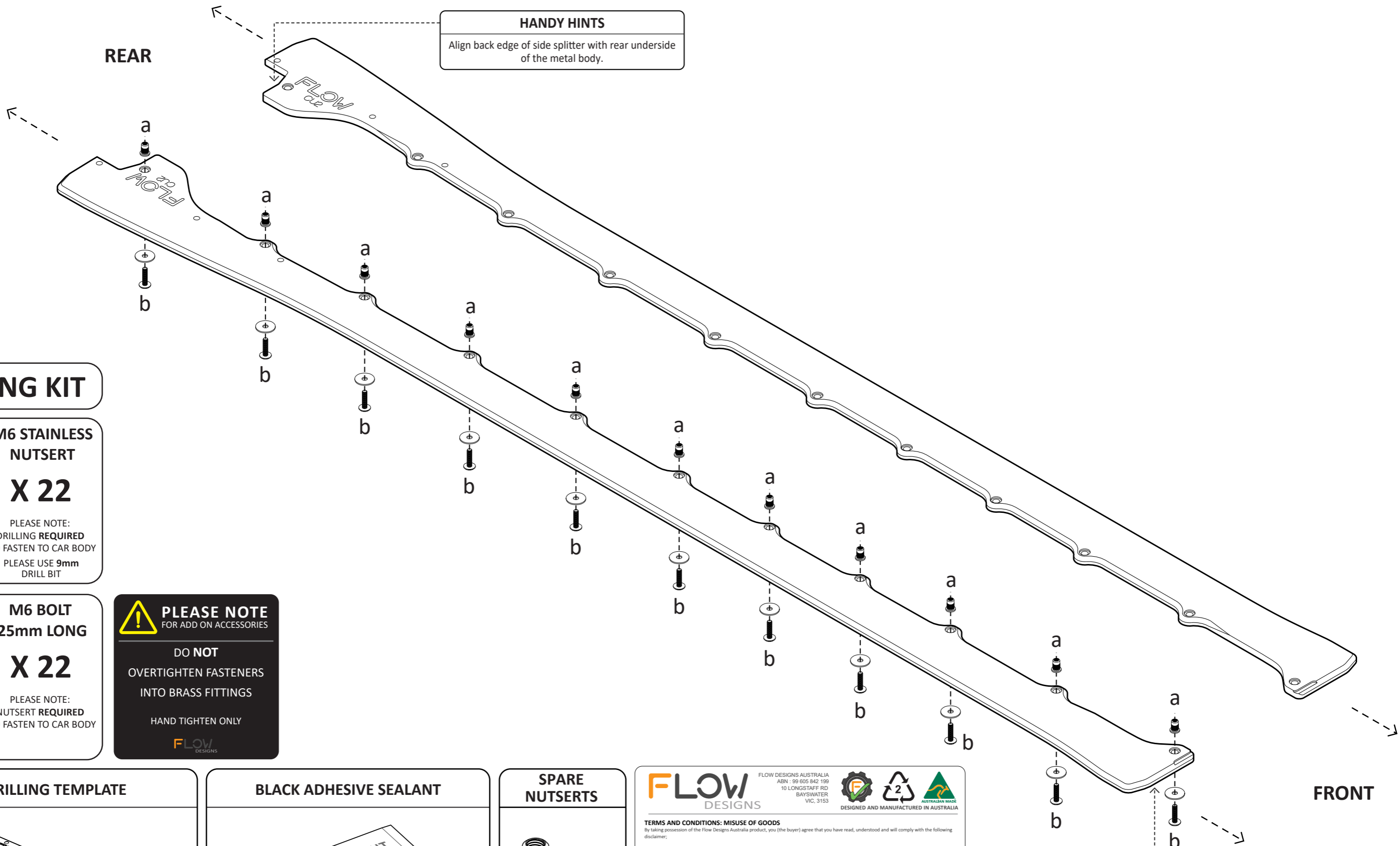

FITTING KIT

a

**M6 STAINLESS
NUTSERT**

X 22



LARGE FLANGE
OD 9MM

PLEASE NOTE:
DRILLING REQUIRED
TO FASTEN TO CAR BODY
PLEASE USE 9mm
DRILL BIT

b

**M6 BOLT
25mm LONG**

X 22

OD 25

25mm M6

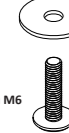

PLEASE NOTE:
NUTSERT REQUIRED
TO FASTEN TO CAR BODY



PLEASE NOTE
FOR ADD ON ACCESSORIES

DO NOT
OVERTIGHTEN FASTENERS
INTO BRASS FITTINGS

HAND TIGHTEN ONLY

FLOW
DESIGNS

DRILLING TEMPLATE

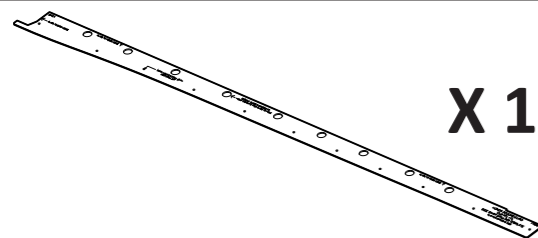

X 1

BLACK ADHESIVE SEALANT

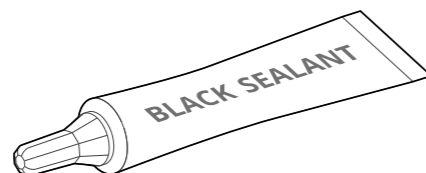

X 1

SPARE NUTSERTS



LARGE FLANGE
OD 9MM

X 2

FLOW
DESIGNS

FLOW DESIGNS AUSTRALIA
ABN : 99 605 842 199
10 LONGSTAFF RD
BAYSWATER
VIC. 3153



DESIGNED AND MANUFACTURED IN AUSTRALIA

TERMS AND CONDITIONS: MISUSE OF GOODS

By taking possession of the Flow Designs Australia product, you (the buyer) agree that you have read, understood and will comply with the following disclaimer:

- This product may not be suitable for road use in your area. We cannot be held liable for any penalties or infringements that may occur after installing any of our products.
- We cannot guarantee that this product will comply with all subsequent aftermarket products you have applied to your vehicle.
- It is not legal to fit parts onto a road registered vehicle unless it carries and meets the design rules and public road regulations of your area, region and/or country.
- We do our best effort to consider safety when designing our products. We want the scene to be a safe place for everyone!

This disclaimer absolves us (Flow Designs Australia) of any and all liability or breaches to any requirement as a result of installation of our products.

www.flowdesignsaustralia.com

FRONT

HANDY HINTS

For best fitment, align bevel of side splitter with front and back edge of side skirt.