

FITTING DIAGRAM

HOLDEN VE / VF COMMODORE UTE- SERIES 1 & SERIES 2:
REAR DIFFUSER + FLOW - LOCK DIFFUSER FINS

INSTALLATION AND FITTING SERVICES

If you are having any difficulties please seek professional advice from the listed International and Domestic Authorised Dealers on our website.

www.flowdesignsaustralia.com

BUMPER REMOVAL NOT REQUIRED

HANDY HINTS

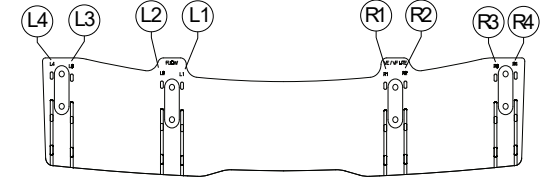

- Align FLOW-LOCK Fins to their corresponding slots.
- Please ensure to allocate the correct FLOW-LOCK Fin to the correct corresponding slot (L1 into L1 slot, R1 into R1 slot etc.)
- Ensure textured side of fin is facing out from opposing fin
- Push fin firmly into the slots until a clicking sound is heard.
- Check both top and bottom locking tabs have securely seated.

Please Note: Once fins have been locked into position, they will be difficult to remove.

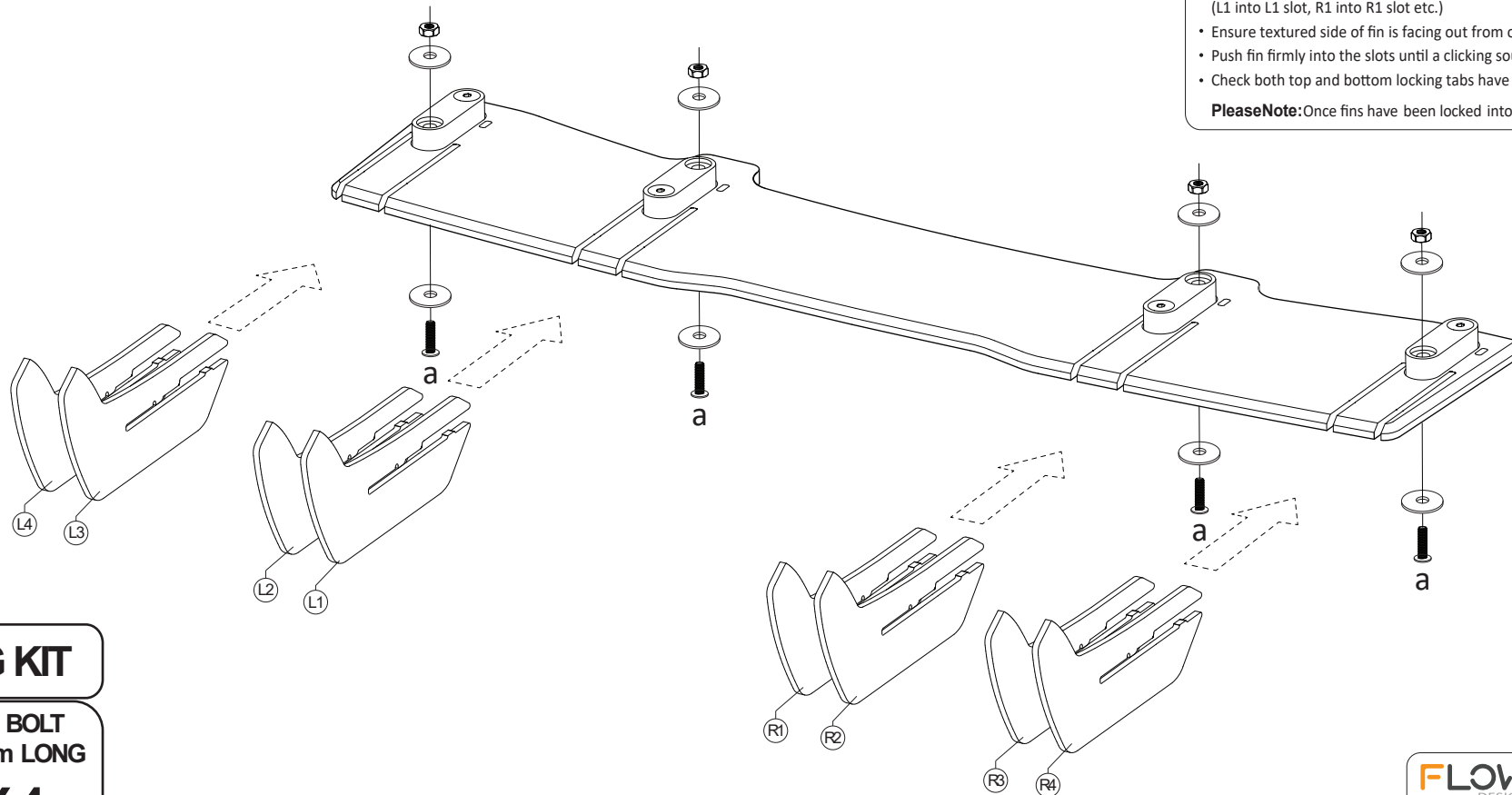

FITTING KIT

a

M6 BOLT
40mm LONG

X4

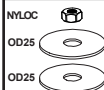

PLEASE NOTE:
DRILLING **REQUIRED**
TO FASTEN TO BUMPER

PLEASE USE 8mm DRILL BIT

FLOW-LOCK
TECHNOLOGY

FLOW
DESIGNS

FLOW DESIGNS AUSTRALIA
ABN: 58 636 842 190
15 LOGGERS DRIVE
SAVANNAH
VIC 3135



TERMS AND CONDITIONS : MISUSE OF GOODS

This Product application is not intended for public road registered vehicles within Australia. Regulations may vary from Countries outside of Australia. Please check your Country's and State's road regulations before installing on a vehicle intended for public road use.

Flow Designs Australia PTY LTD will not be liable for any liabilities in relation to any use of the goods other than in strict accordance with the Company's instructions and for the purpose and application for which the goods were supplied by the Company.

- That it will acquiesce itself with the requirements of all relevant government or statutory and other authorities, bodies or corporations relating to the goods and/or services and to the applications to which the goods and/or services are to be put;
- That it will ensure that any purchaser of goods from it will also acquiesce itself with, and will comply with, such requirements;
- That it will indemnify the Company against any liability resulting from a breach of any such requirements.

www.flowdesignsaustralia.com