

FITTING DIAGRAM

FORD MUSTANG S550 FN GT REAR DIFFUSER + FLOW-LOCK FINS

INSTALLATION AND FITTING SERVICES

If you are having any difficulties please seek professional advise from the listed International and Domestic Authorised Dealers on our website.

www.flowdesignsaustralia.com

BUMPER REMOVAL NOT REQUIRED

HANDY HINTS

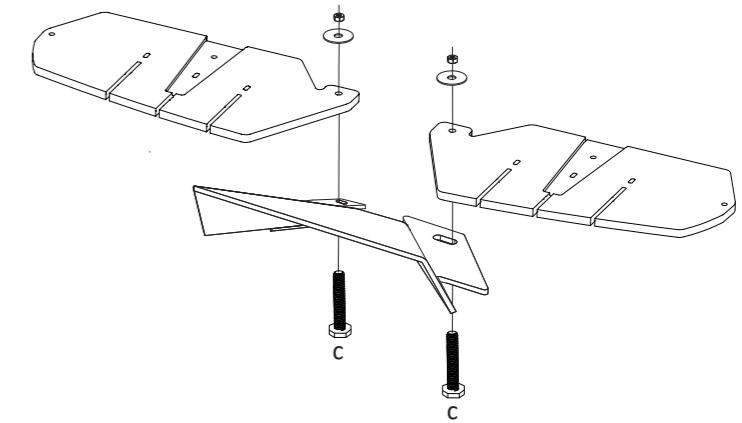

- To install optional centre bracket, align with inside of Flow Designs diffusers.
- Using bolts (c.), fasten optional centre bracket and Flow Designs Diffusers to OEM diffuser.

HANDY HINTS

- Fit pocket in Valance to OEM Fins and align back edge of pocket to be flush with back edge of stock diffuser for correct alignment

HANDY HINTS

- To install inner bolt first remove stock middle screw
- Using a 6mm drillbit, drill through stock clipping.
- Install bolt (c.) in drilled out hole

FITTING KIT

a
M5 BOLT
25mm LONG
X 2

M5
OD 10
M5
OD 18

PLEASE NOTE:
DRILLING REQUIRED
TO FASTEN TO BUMPER
PLEASE USE 6mm DRILL BIT

b
M5 BOLT
25mm LONG
X 2

M5
OD 18
M5
OD 25

PLEASE NOTE:
DRILLING REQUIRED
TO FASTEN TO BUMPER
PLEASE USE 6mm DRILL BIT

c
M5 BOLT
50mm LONG
X 2

M5
OD 18
M5
OD 25

PLEASE NOTE:
DRILLING REQUIRED
TO FASTEN TO BUMPER
PLEASE USE 6mm DRILL BIT

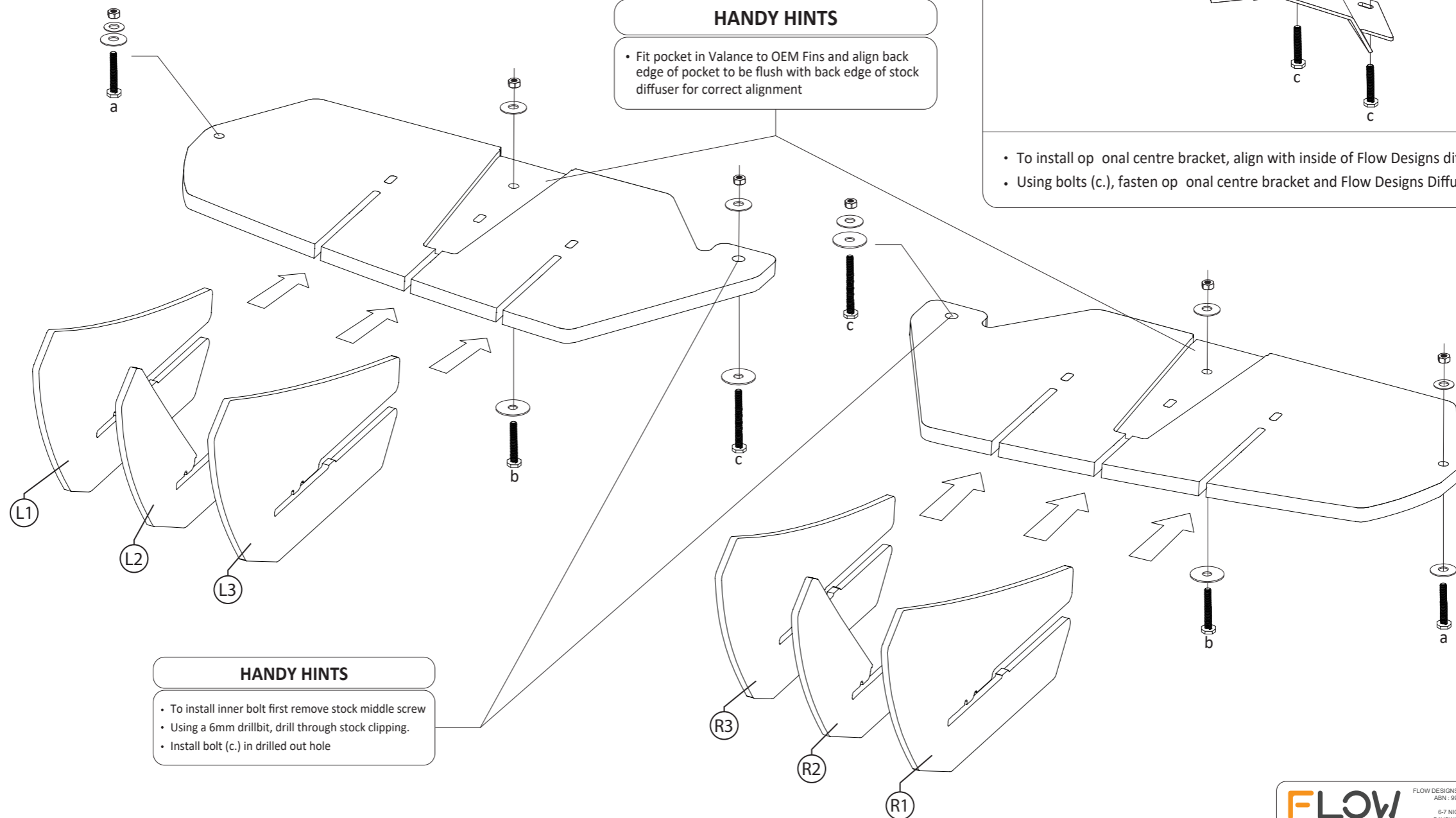

TERMS AND CONDITIONS : MISUSE OF GOODS
By taking possession of this Flow Designs Australia product, you (the buyer) agree that you have read, understood and will comply with the following disclaimer:

- This product may not be suitable for road use in your area. We cannot be held liable for any penalties or infringements that may occur after installing any of our products.
- We cannot guarantee that this product will comply with subsequent aftermarket products you have applied to your vehicle.
- It is not legal to fit parts onto a road registered vehicle unless it carries and meets the design rules and public road regulations of your area, region and/or country.
- We do make our best effort to consider safety when designing our products, we want the scene to be a safe place for everyone!

This disclaimer absolves us (Flow Designs Australia) of any and all liability for breaches to any requirement as a result of installation of our products.

www.flowdesignsaustralia.com