

FITTING DIAGRAM

FORD MK3.5 FOCUS ST : REAR DIFFUSER

INSTALLATION AND FITTING SERVICES

If you are having any difficulties please seek professional advise from the listed International and Domestic Authorised Dealers on our website.

www.flowdesignsaustralia.com

BUMPER REMOVAL NOT REQUIRED

FITTING KIT

a
M6 BOLT
30mm LONG
X 8

PLEASE NOTE:
DRILLING REQUIRED
TO FASTEN TO BUMPER
PLEASE USE 8mm DRILL BIT

b
M6 BOLT
25mm LONG
X 6

PLEASE NOTE:
DRILLING REQUIRED
TO FASTEN TO BUMPER
PLEASE USE 8mm DRILL BIT

c
M6 BOLT
12mm LONG
X 4

PLEASE NOTE:
DRILLING REQUIRED
TO FASTEN TO BUMPER
PLEASE USE 8mm DRILL BIT

d
BLACK SCREWS
25mm LONG
X 2

PLEASE NOTE:
DRILLING NOT REQUIRED
TO FASTEN TO SIDE SKIRT

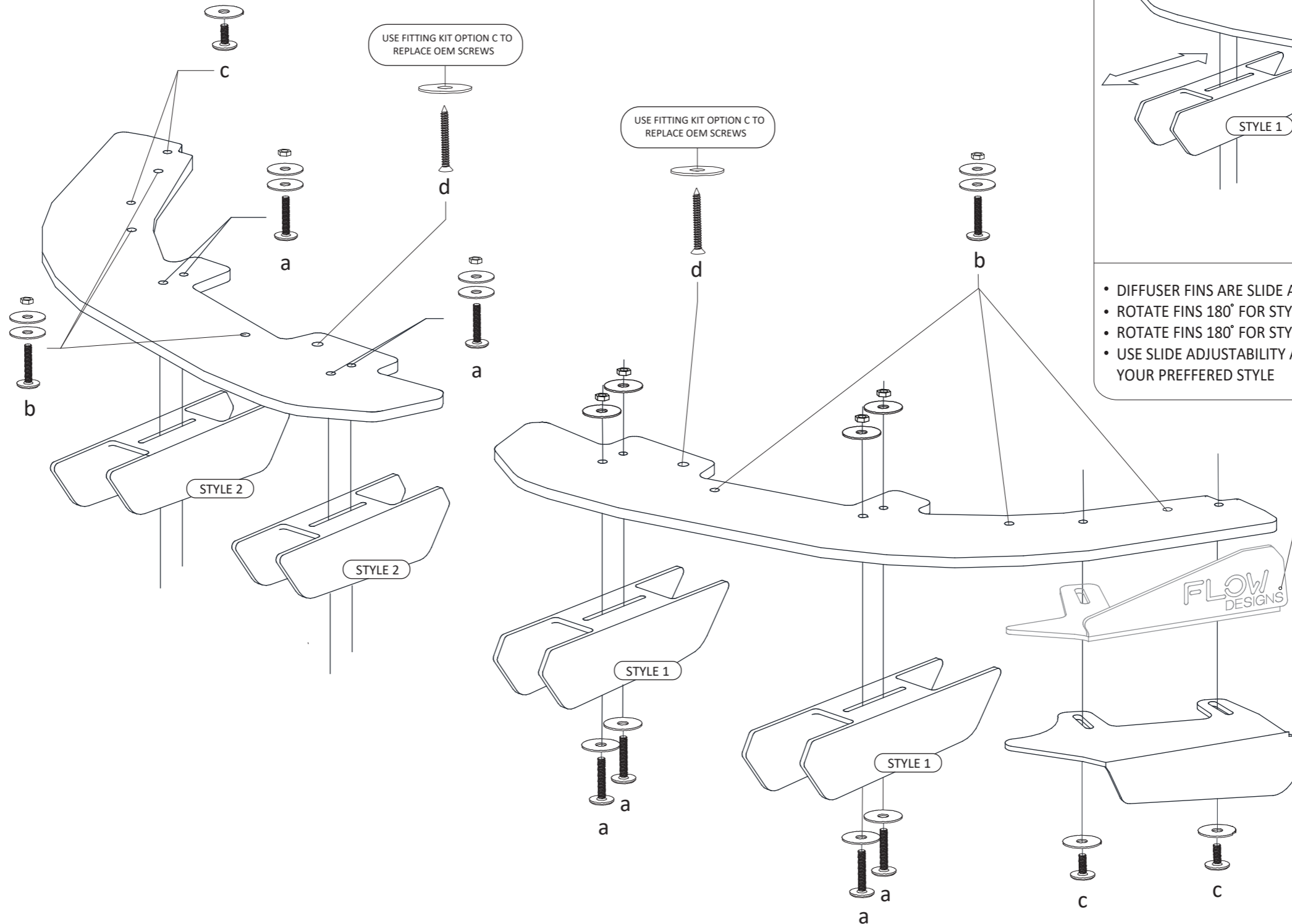

HANDY HINTS

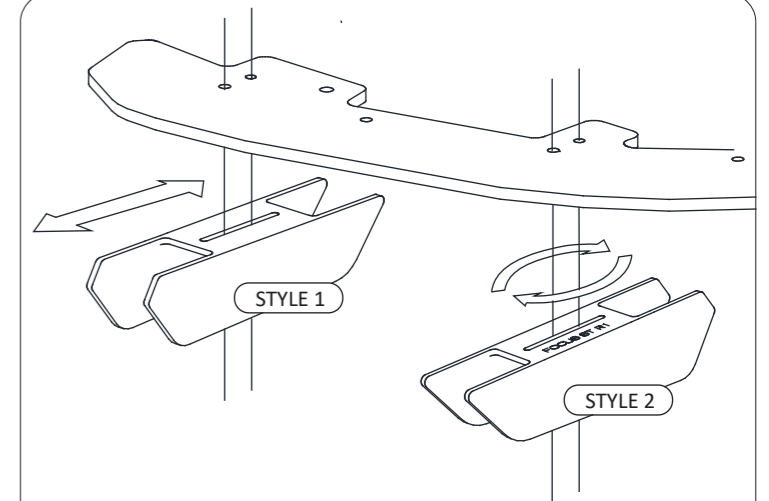

- DIFFUSER FINS ARE SLIDE ADJUSTABLE
- ROTATE FINS 180° FOR STYLE 1
- ROTATE FINS 180° FOR STYLE 2
- USE SLIDE ADJUSTABILITY AND ROTATING FEATURE TO SUIT YOUR PREFERRED STYLE

TOP WINGLET AVAILABLE SEPERATELEY. PLEASE VISIT OUR WEBSITE FOR INFORMATION