

FITTING DIAGRAM

FORD FGX : FRONT BOLT-ON INSTRUCTIONS

INSTALLATION AND FITTING SERVICES

If you are having any difficulties please seek professional advice from the listed International and Domestic Authorised Dealers on our website.

www.flowdesignsaustralia.com

**BUMPER REMOVAL
NOT REQUIRED**

CONFIGURATION 1

FRONT EXTENSIONS ONLY

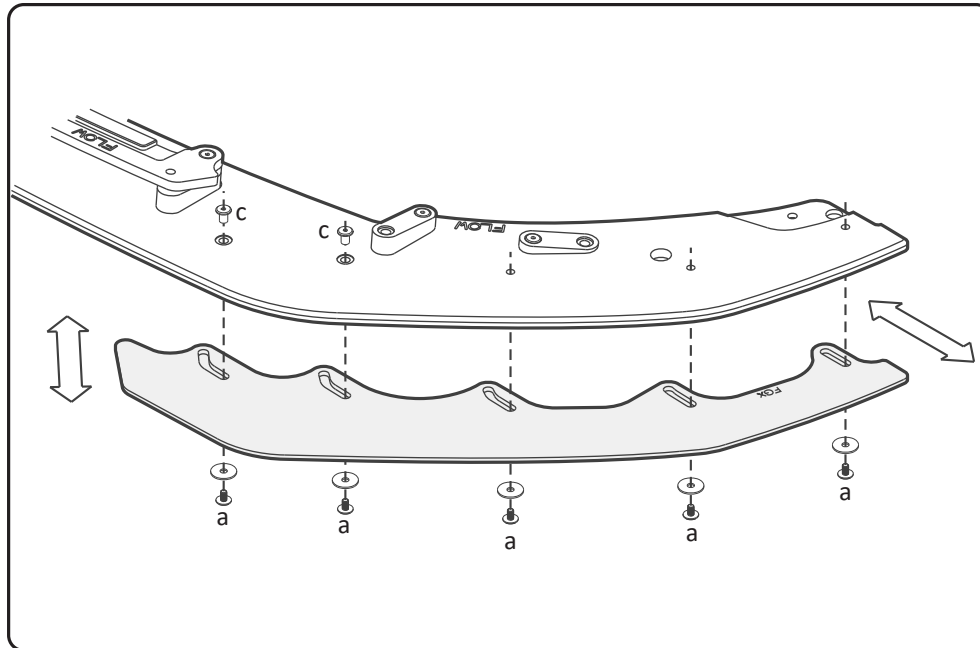

- Insert bolts loosely into allocated brass thread locations.
- Slide extensions in and out to your liking.
- Use a 4mm hex key to hand tighten.

PLEASE NOTE : DO NOT OVERTIGHTEN - These bolts do not need to be very tight.

CONFIGURATION 2

FRONT WINGLETS ONLY

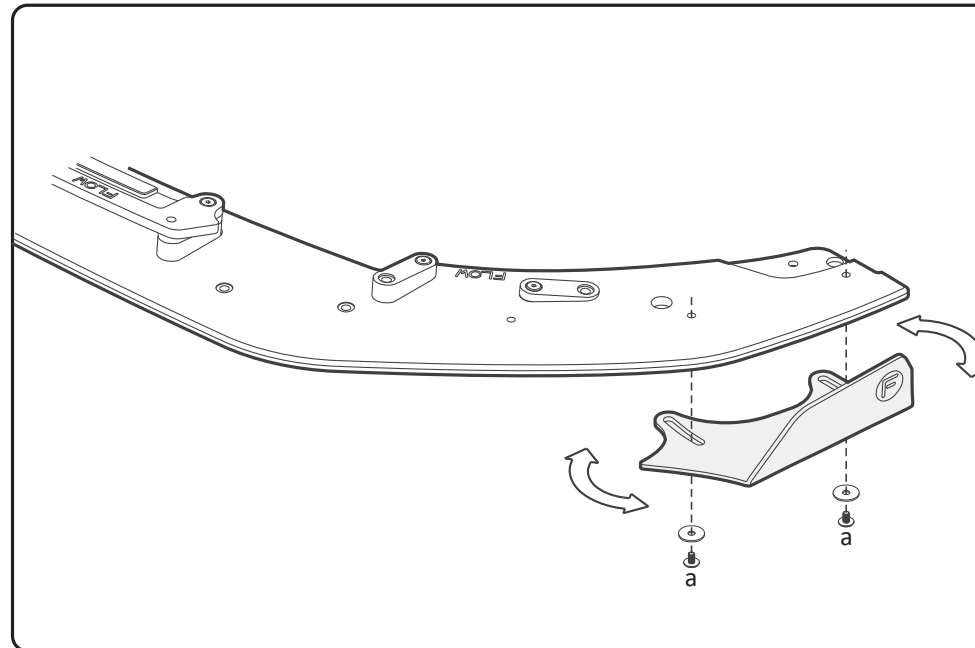

- Insert bolts loosely into allocated brass thread locations.
- Slide and pivot winglets to your liking.
- Use a 4mm hex key to hand tighten.

PLEASE NOTE : DO NOT OVERTIGHTEN - These bolts do not need to be very tight.

CONFIGURATION 3

FRONT EXTENSIONS AND WINGLETS

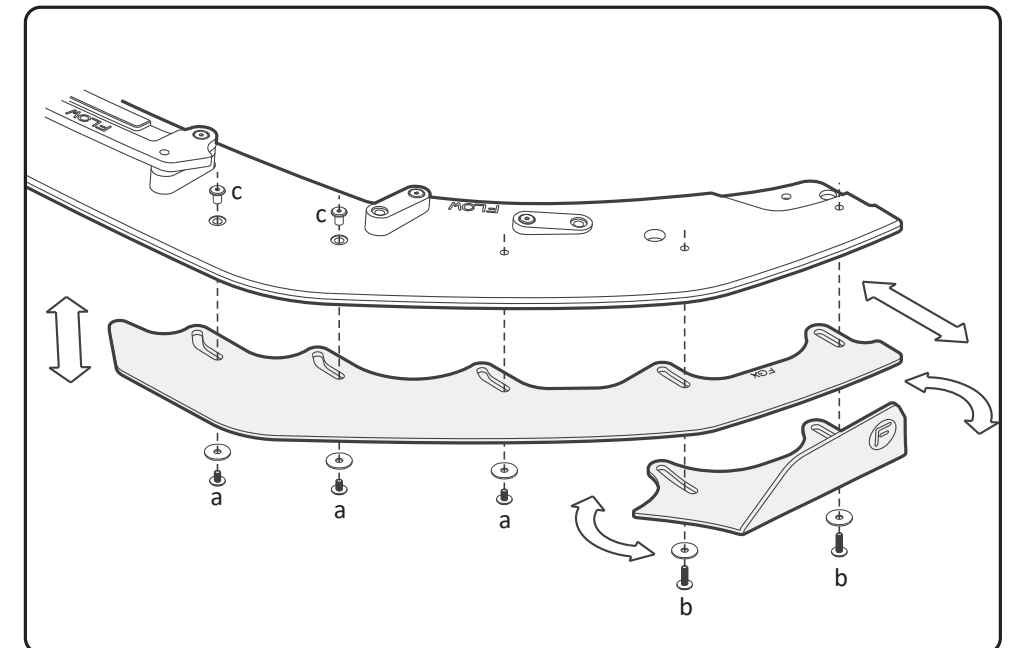

- Insert bolts loosely into allocated brass thread locations.
- Slide and pivot extensions and winglets to your liking.
- Use a 4mm hex key to hand tighten.

PLEASE NOTE : DO NOT OVERTIGHTEN - These bolts do not need to be very tight.

FITTING KIT

a	<p>M6 BOLT 10mm LONG X 10</p> <p>PLEASE NOTE: DRILLING NOT REQUIRED TO FASTEN TO SPLITTER DO NOT OVERTIGHTEN</p>	b	<p>M6 BOLT 20mm LONG X 4</p> <p>PLEASE NOTE: DRILLING NOT REQUIRED TO FASTEN TO SPLITTER DO NOT OVERTIGHTEN</p>	c	<p>BLACK CHICAGO BOLT X 4</p> <p>PLEASE NOTE: DRILLING NOT REQUIRED TO FASTEN TO SPLITTER</p>
---	---	---	--	---	--

PLEASE NOTE
FOR ADD ON ACCESSORIES

**DO NOT
OVERTIGHTEN FASTENERS
INTO BRASS FITTINGS**

HAND TIGHTEN ONLY

FLOW
DESIGNS

FLOW
DESIGNS

FLOW DESIGNS AUSTRALIA
ABN : 99 605 842 199
10 LONGSTAFF RD
BAYSWATER
VIC, 3153

DESIGNED AND MANUFACTURED IN AUSTRALIA

TERMS AND CONDITIONS: MISUSE OF GOODS
By taking possession of the Flow Designs Australia product, you (the buyer) agree that you have read, understood and will comply with the following disclaimer:

- This product may not be suitable for road use in your area. We cannot be held liable for any penalties or infringements that may occur after installing any of our products.
- We cannot guarantee that this product will comply with all subsequent aftermarket products you have applied to your vehicle.
- It is not legal to fit parts onto a road registered vehicle unless it carries and meets the designs rules and public road regulations of your area, region and/or country.
- We do our best effort to consider safety when designing our products. We want the scene to be a safe place for everyone!

This disclaimer absolves us (Flow Designs Australia) of any and all liability or breaches to any requirement as a result of installation of our products.

www.flowdesignsaustralia.com