

FITTING DIAGRAM

FORD MK3 FOCUS RS : REAR SPAT + FLOW-LOCK FINS

INSTALLATION AND FITTING SERVICES

If you are having any difficulties please seek professional advise from the listed International and Domestic Authorised Dealers on our website.

www.flowdesignsaustralia.com

BUMPER REMOVAL NOT REQUIRED

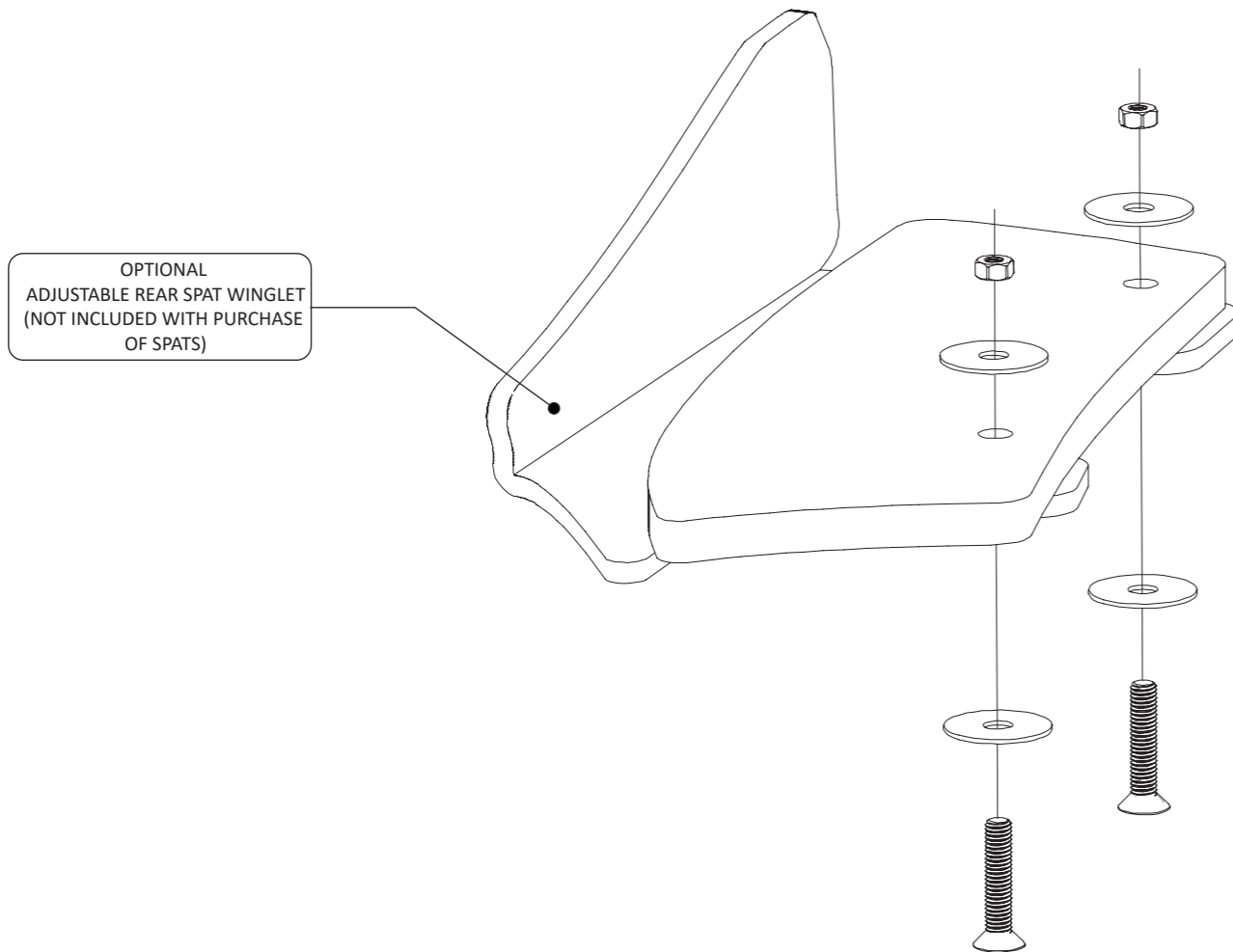

FITTING KIT

a

M6 BOLT
30mm LONG

X 4

PLEASE NOTE:
DRILLING REQUIRED
TO FASTEN TO BUMPER

PLEASE USE 8mm DRILL BIT

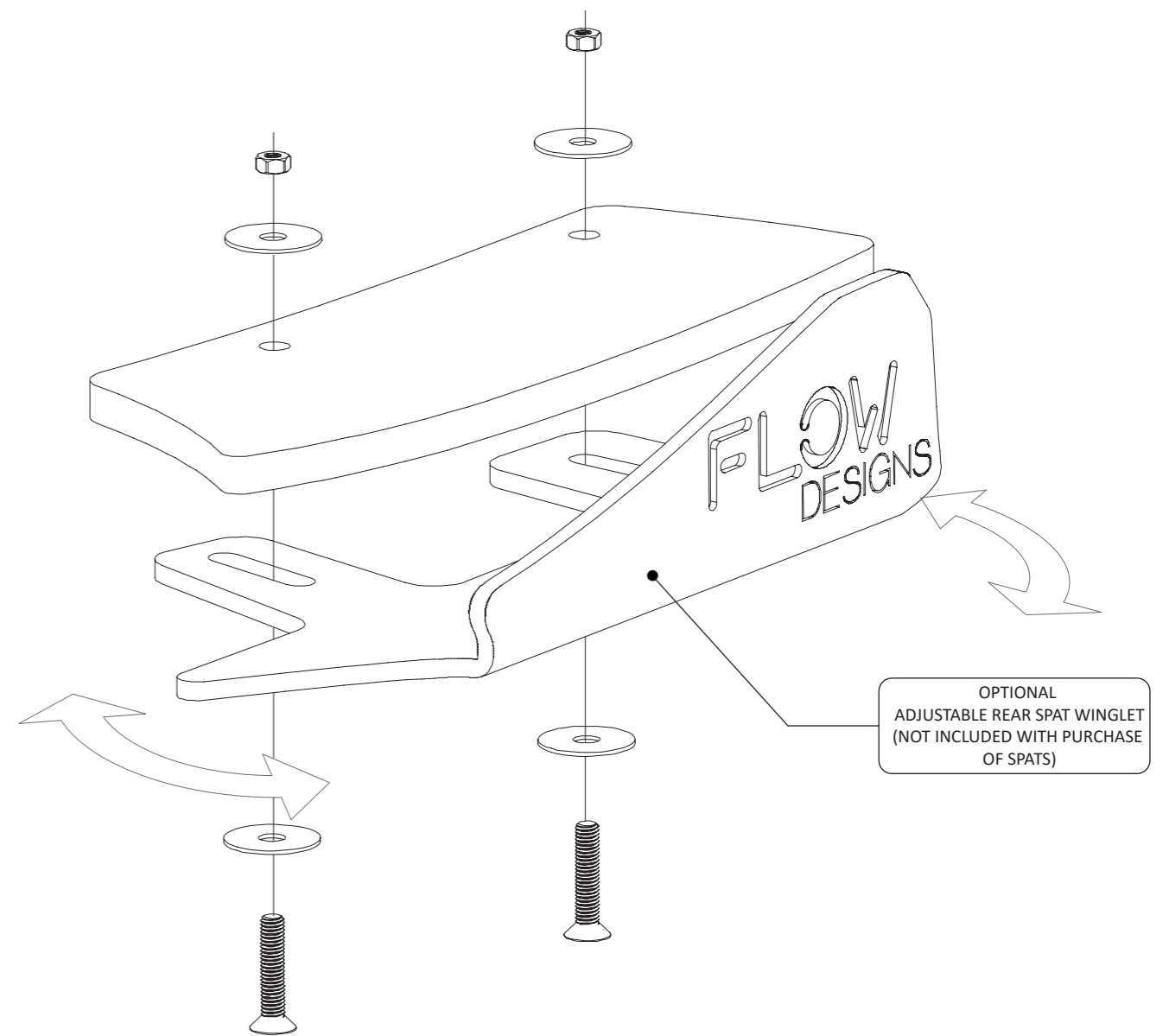

FLOW-LOCK
TECHNOLOGY

FLOW
DESIGNS

