

FITTING DIAGRAM

FORD MK3 FOCUS RS: FRONT EXTENSION + FRONT WINGLETS

INSTALLATION AND FITTING SERVICES

If you are having any difficulties please seek professional advise from the listed International and Domestic Authorised Dealers on our website.

www.flowdesignsaustralia.com

BUMPER REMOVAL NOT REQUIRED

CONFIGURATION 1

FRONT EXTENSIONS ONLY

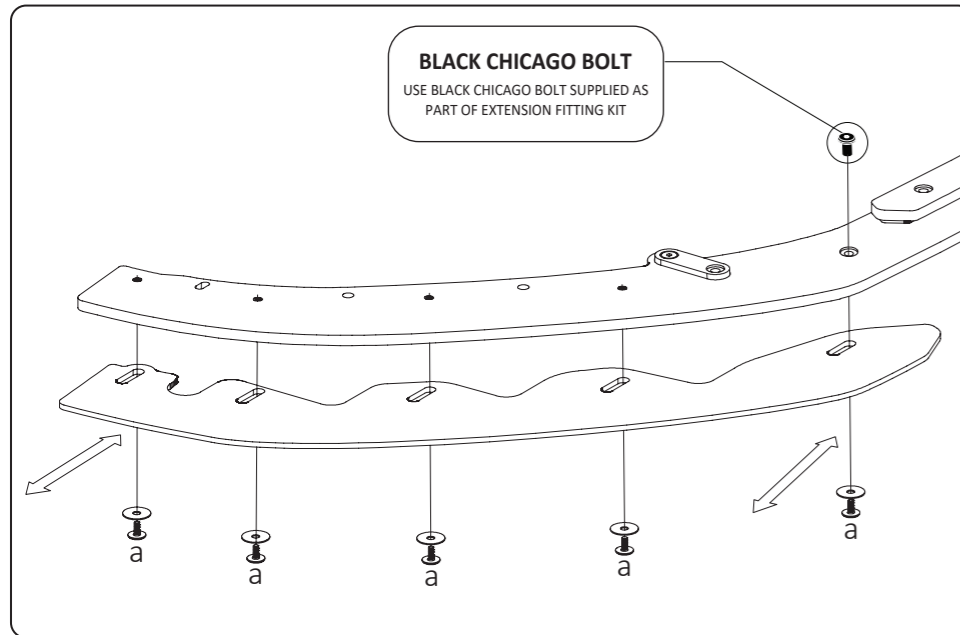

- Insert bolts loosely into allocated brass thread locations.
- Slide extensions in and out to your liking.
- Use a 4mm Alan Key to hand tighten.

PLEASE NOTE : DO NOT OVERTIGHTEN - These bolts do not need to be very tight.

CONFIGURATION 2

FRONT WINGLETS ONLY

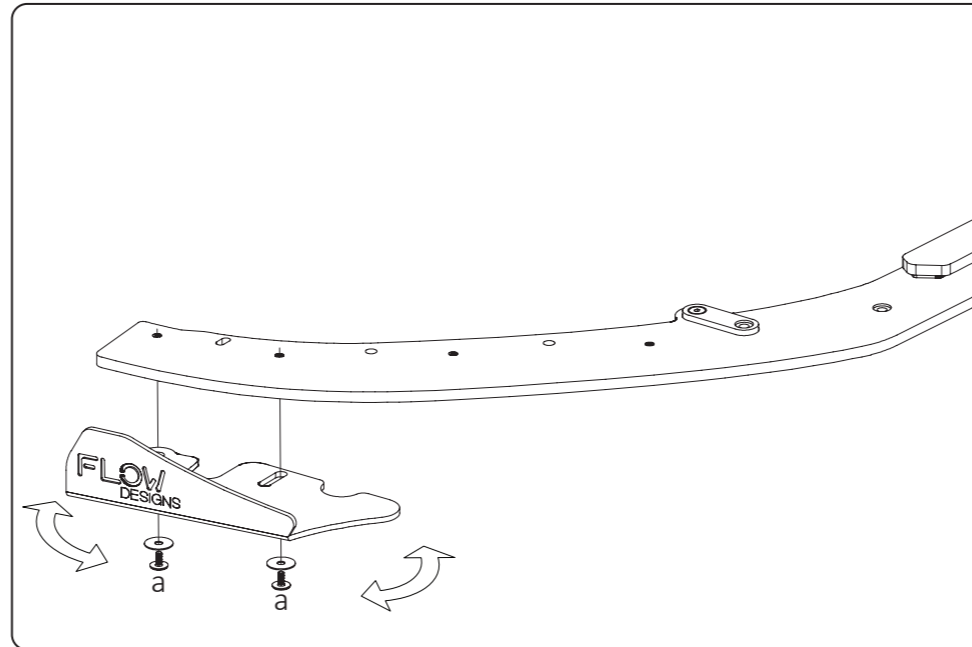

- Insert bolts loosely into allocated brass thread locations.
- Slide and pivot winglets to your liking.
- Use a 4mm Alan Key to hand tighten.

PLEASE NOTE : DO NOT OVERTIGHTEN - These bolts do not need to be very tight.

CONFIGURATION 3

FRONT EXTENSIONS AND WINGLETS

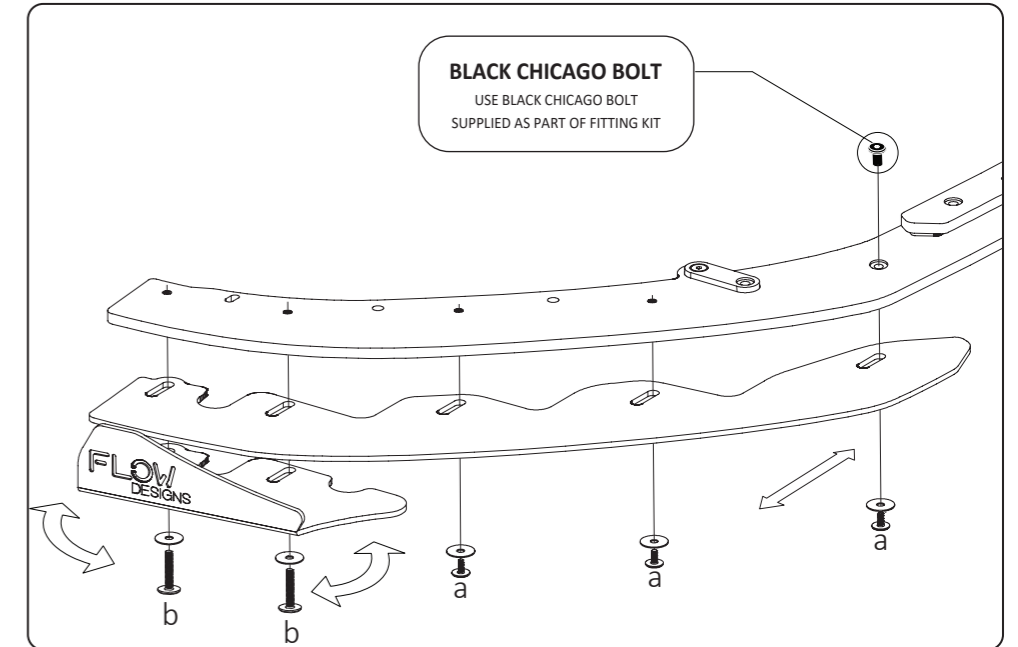



- Insert bolts loosely into allocated brass thread locations.
- Slide and pivot extensions and winglets to your liking.
- Use a 4mm Alan Key to hand tighten.

PLEASE NOTE : DO NOT OVERTIGHTEN - These bolts do not need to be very tight.

FITTING KIT

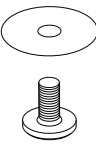
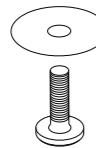
BLACK CHICAGO BOLT SUPPLIED WITH EXTENSIONS

<p>a</p> 	<p>M6 BOLT 12mm LONG X 10</p> <p>PLEASE NOTE: DRILLING NOT REQUIRED TO FASTEN TO SPLITTER DO NOT OVERTIGHTEN</p>
<p>b</p> 	<p>M6 BOLT 20mm LONG X 4</p> <p>PLEASE NOTE: DRILLING NOT REQUIRED TO FASTEN TO SPLITTER DO NOT OVERTIGHTEN</p>

<p>c</p> 	<p>BLACK CHICAGO BOLT X 2</p> <p>PLEASE NOTE: DRILLING NOT REQUIRED TO FASTEN TO SPLITTER DO NOT OVERTIGHTEN</p>
---	---

PLEASE NOTE
FOR ADD ON ACCESSORIES

**DO NOT
OVERTIGHTEN FASTENERS
INTO BRASS FITTINGS**

HAND TIGHTEN ONLY

FLOW
DESIGNS

FLOW DESIGNS

FLOW DESIGNS AUSTRALIA
ABN : 99 605 842 199
FACTORY 11
6-7 NICOLE CLOSE
BAYSWATER NORTH
VIC, 3153

DESIGNED AND MANUFACTURED IN AUSTRALIA

TERMS AND CONDITIONS : MISUSE OF GOODS

By taking possession of this Flow Designs Australia product, you (the buyer) agree that you have read, understood and will comply with the following disclaimer;

- This product may not be suitable for road use in your area. We cannot be held liable for any penalties or infringements that may occur after installing any of our products.
- We cannot guarantee that this product will comply with subsequent aftermarket products you have applied to your vehicle.
- It is not legal to fit parts onto a road registered vehicle unless it carries and meets the design rules and public road regulations of your area, region and/or country.
- We do make our best effort to consider safety when designing our products, we want the scene to be a safe place for everyone!

This disclaimer absolves us (Flow Designs Australia) of any and all liability for breaches to any requirement as a result of installation of our products.

www.flowdesignsaustralia.com