

# FITTING DIAGRAM

BMW F20 PRE LCI M135 REAR SPATS + ADJUSTABLE REAR WINGLETS V3

INSTALLATION AND FITTING SERVICES

If you are having any difficulties please seek professional advise from the listed International and Domestic Authorised Dealers on our website.

www.flowdesignsaustralia.com

**BUMPER REMOVAL  
NOT REQUIRED**

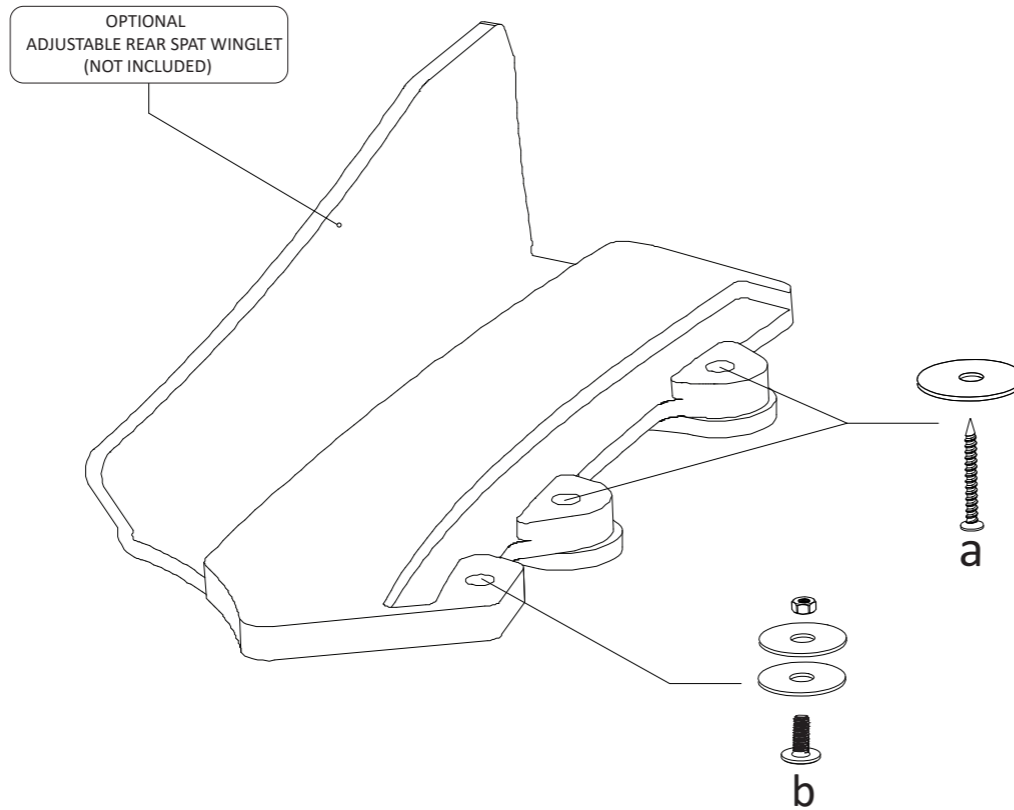

## FITTING KIT (included with spats only)

<b>a</b>	<p>BLACK 8g SELF TAPING SCREW 40mm LONG</p> <p><b>X 4</b></p> <p>PLEASE NOTE: DRILLING NOT REQUIRED TO FASTEN TO BUMPER DO NOT OVERTIGHTEN</p>

<b>b</b>	<p>M6 BOLT 30mm LONG</p> <p><b>X 2</b></p> <p>PLEASE NOTE: DRILLING NOT REQUIRED REPLACES OEM CLIP DO NOT OVERTIGHTEN</p>

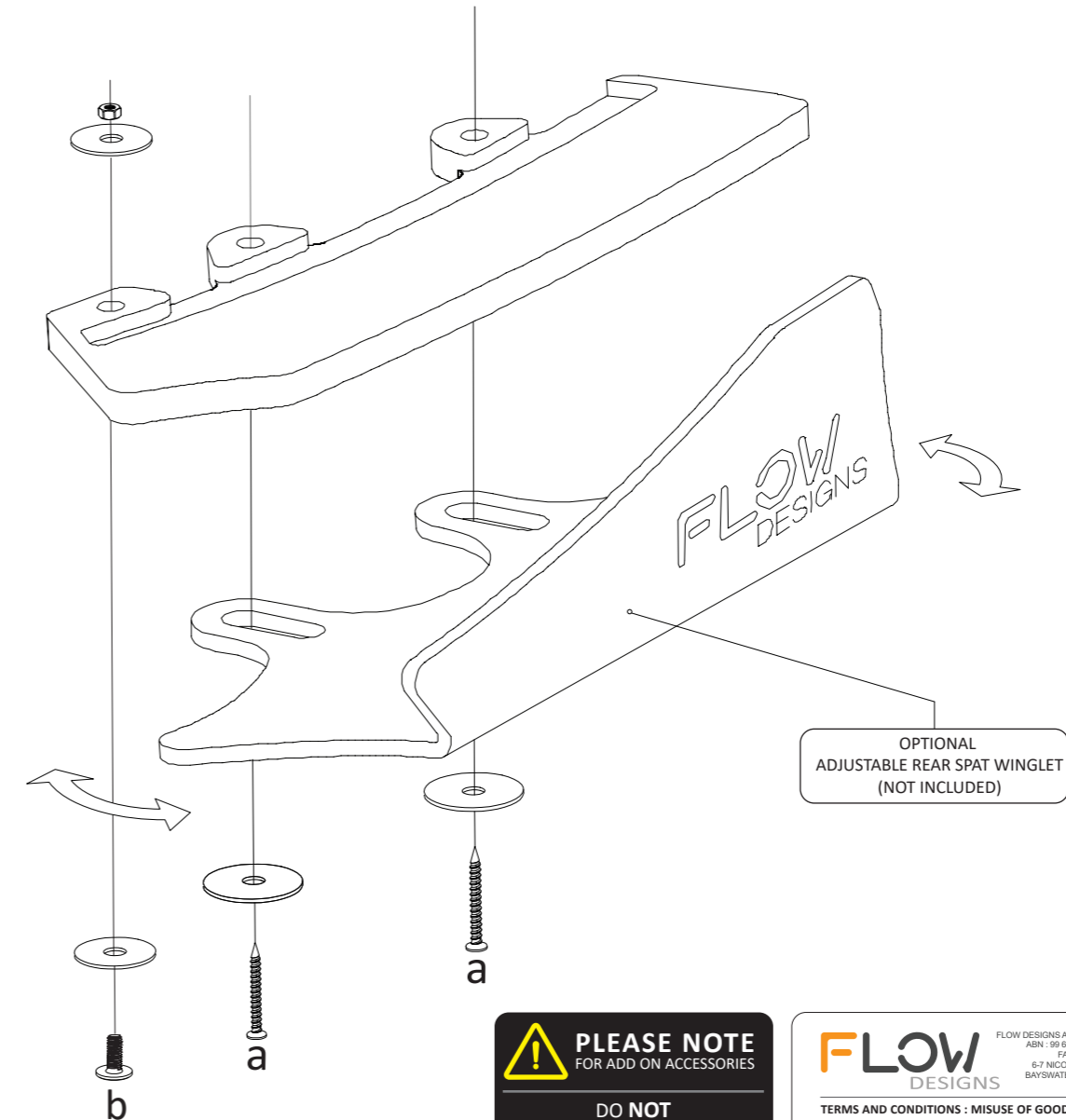

**PLEASE NOTE**  
FOR ADD ON ACCESSORIES

**DO NOT**  
OVERTIGHTEN FASTENERS  
INTO BRASS FITTINGS

HAND TIGHTEN ONLY

**FLOW**  
DESIGNS

**FLOW** DESIGNS AUSTRALIA  
ABN: 99 055 842 199  
FACTORY 11  
6-7 NICOLE CLOSE  
BAYSWATER NORTH VIC. 3153

DESIGNED AND MANUFACTURED IN AUSTRALIA

**TERMS AND CONDITIONS : MISUSE OF GOODS**  
By taking possession of this Flow Designs Australia product, you (the buyer) agree that you have read, understood and will comply with the following disclaimer:

- This product may not be suitable for road use in your area. We cannot be held liable for any penalties or infringements that may occur after installing any of our products.
- We cannot guarantee that this product will comply with subsequent aftermarket products you have applied to your vehicle.
- It is not legal to fit parts onto a road registered vehicle unless it carries and meets the design rules and public road regulations of your area, region and/or country.
- We do make our best effort to consider safety when designing our products, we want the scene to be a safe place for everyone!

This disclaimer absolves us (Flow Designs Australia) of any and all liability for breaches to any requirement as a result of installation of our products.

www.flowdesignsaustralia.com