

FEED CONVEYOR COMPLETE INFORMATION PACKAGE

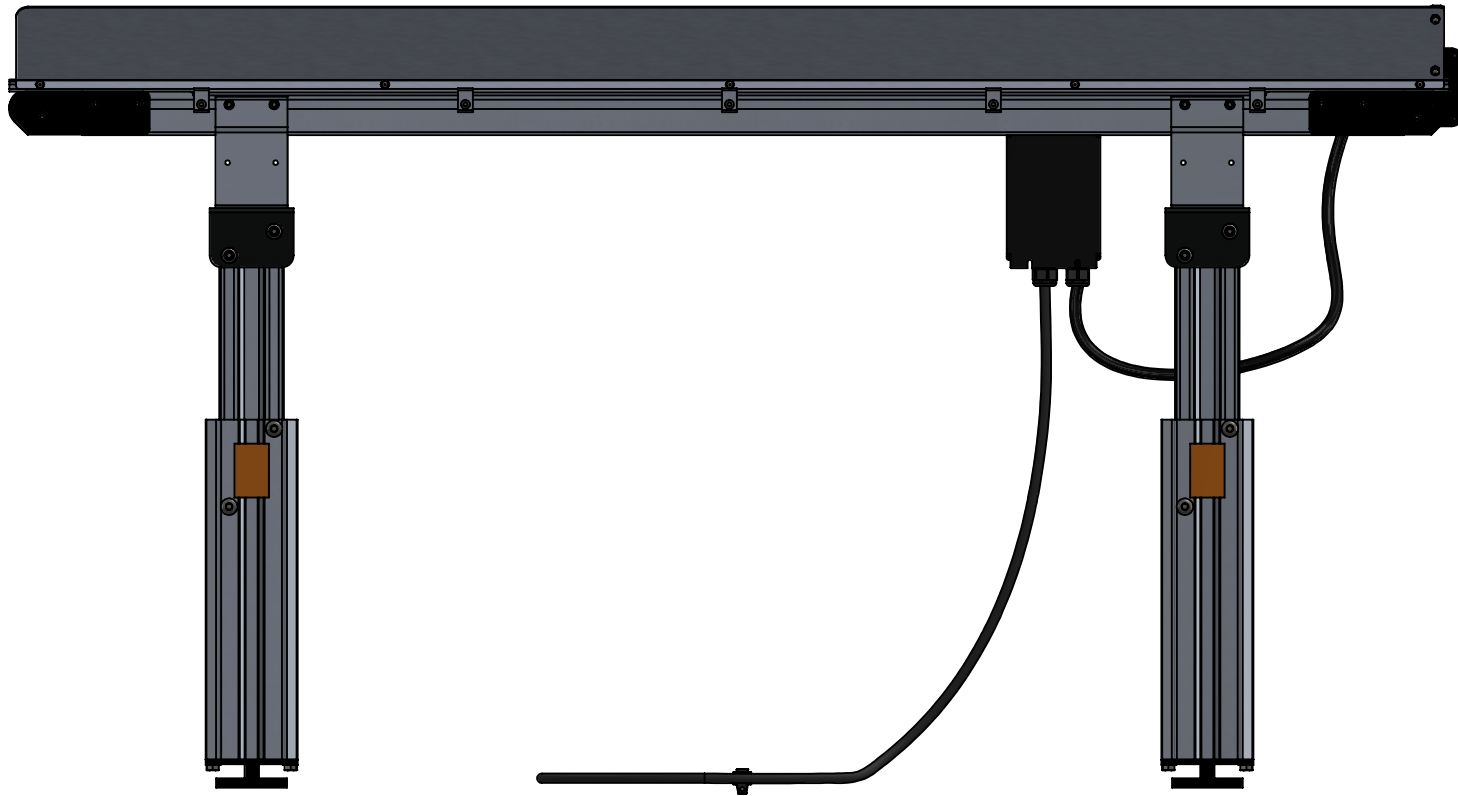

TITLE:
FEED CONVEYOR

DWG. NO.
26-0001-00



FRONT VIEW

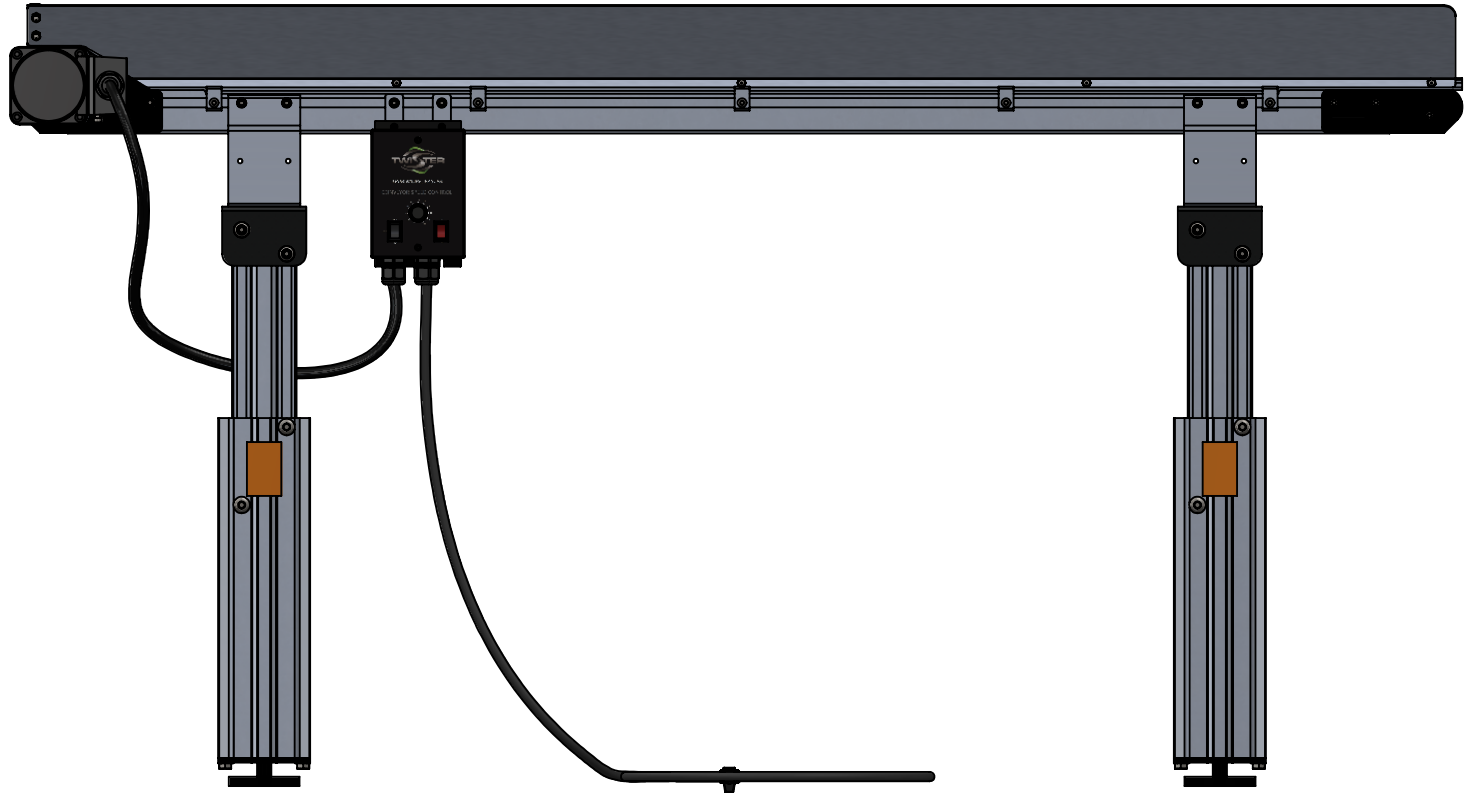

BACK VIEW

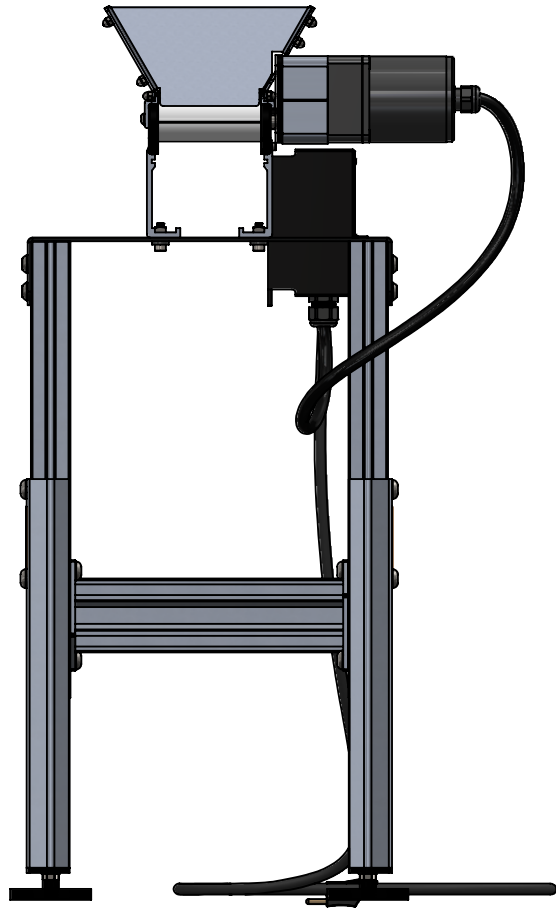

RIGHT VIEW

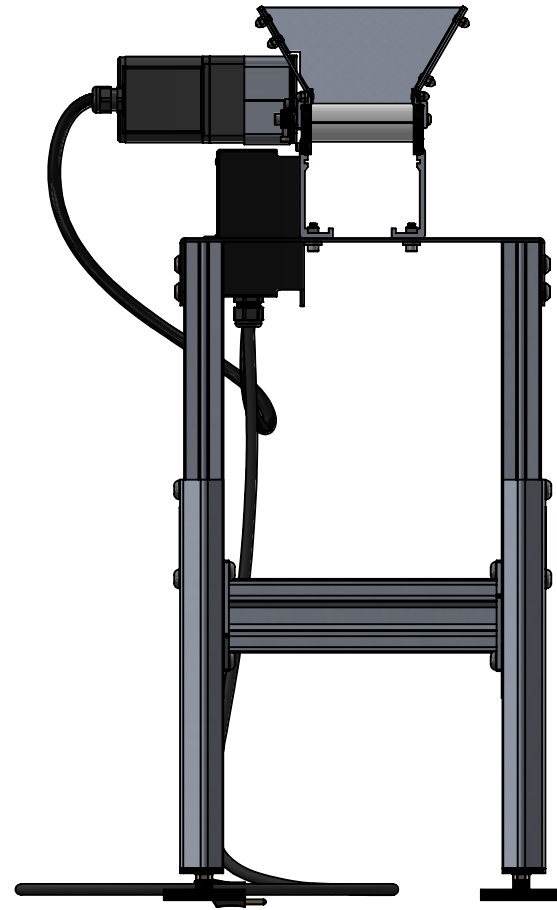

LEFT VIEW

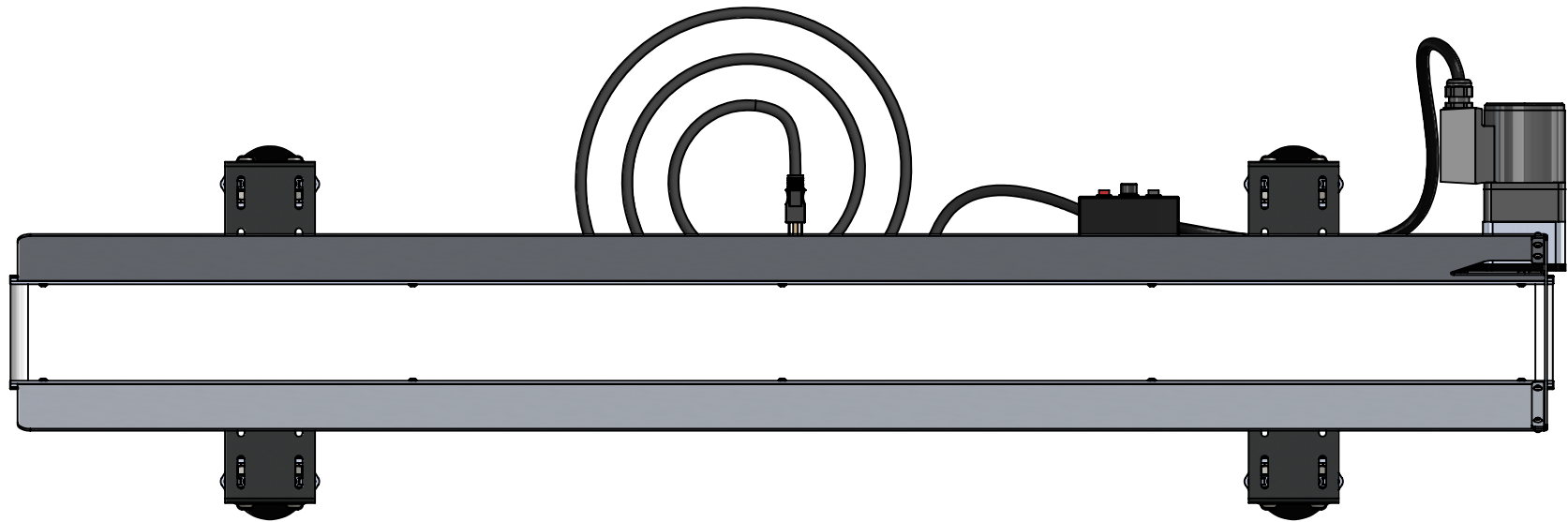

TOP VIEW

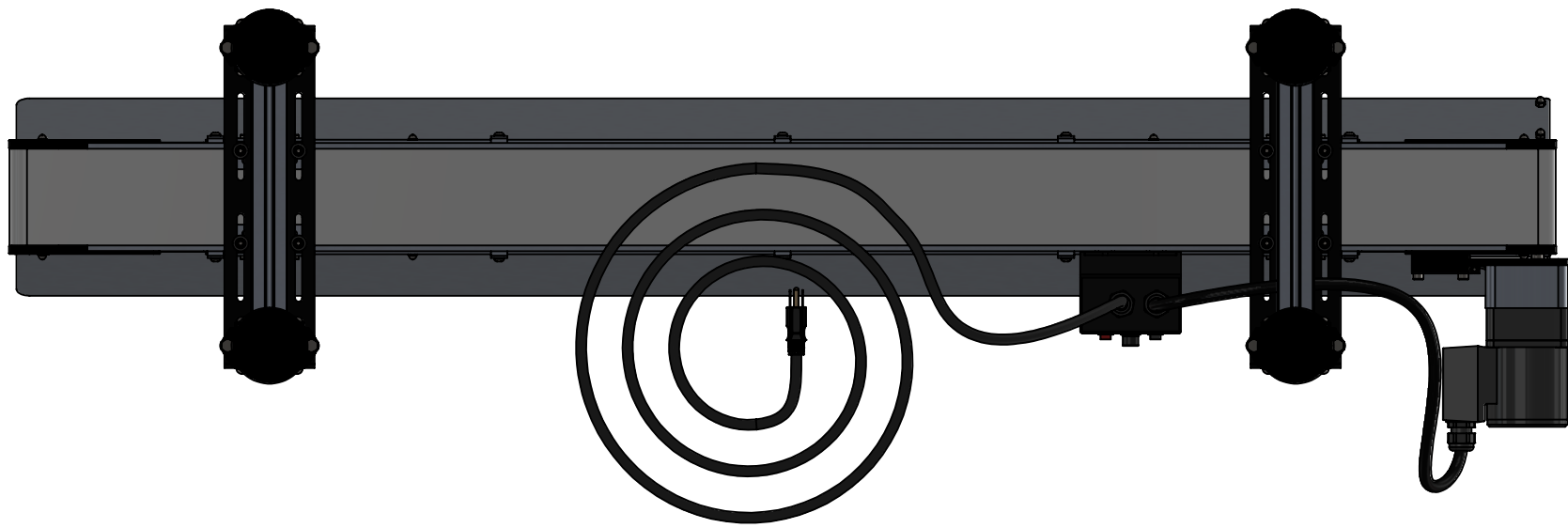

BOTTOM VIEW

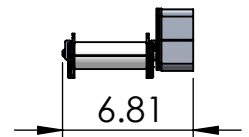
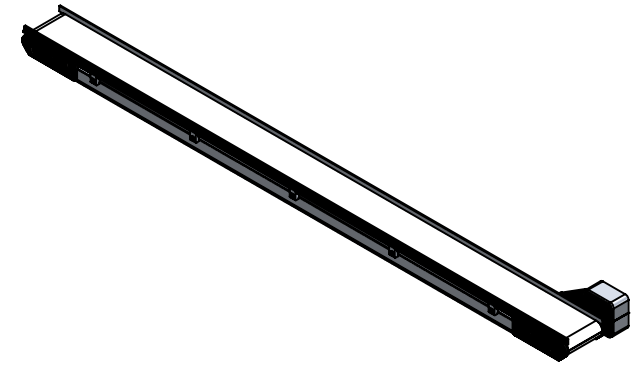
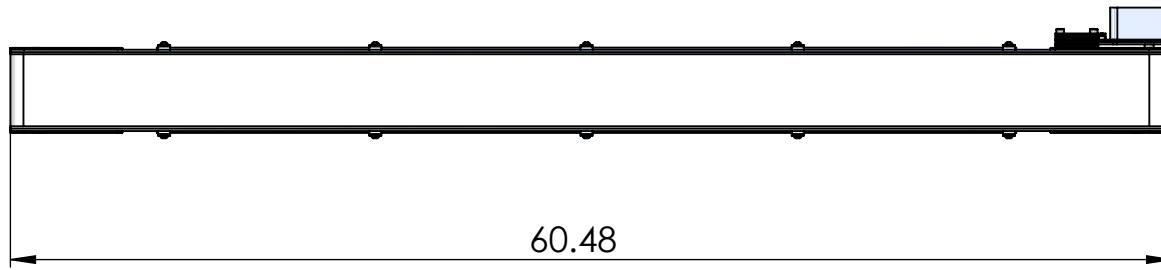

TITLE:
FEED CONVEYOR 95MM (3.75") W/ MOUNTING PACKAGE

DWG. NO.
26-0006-00

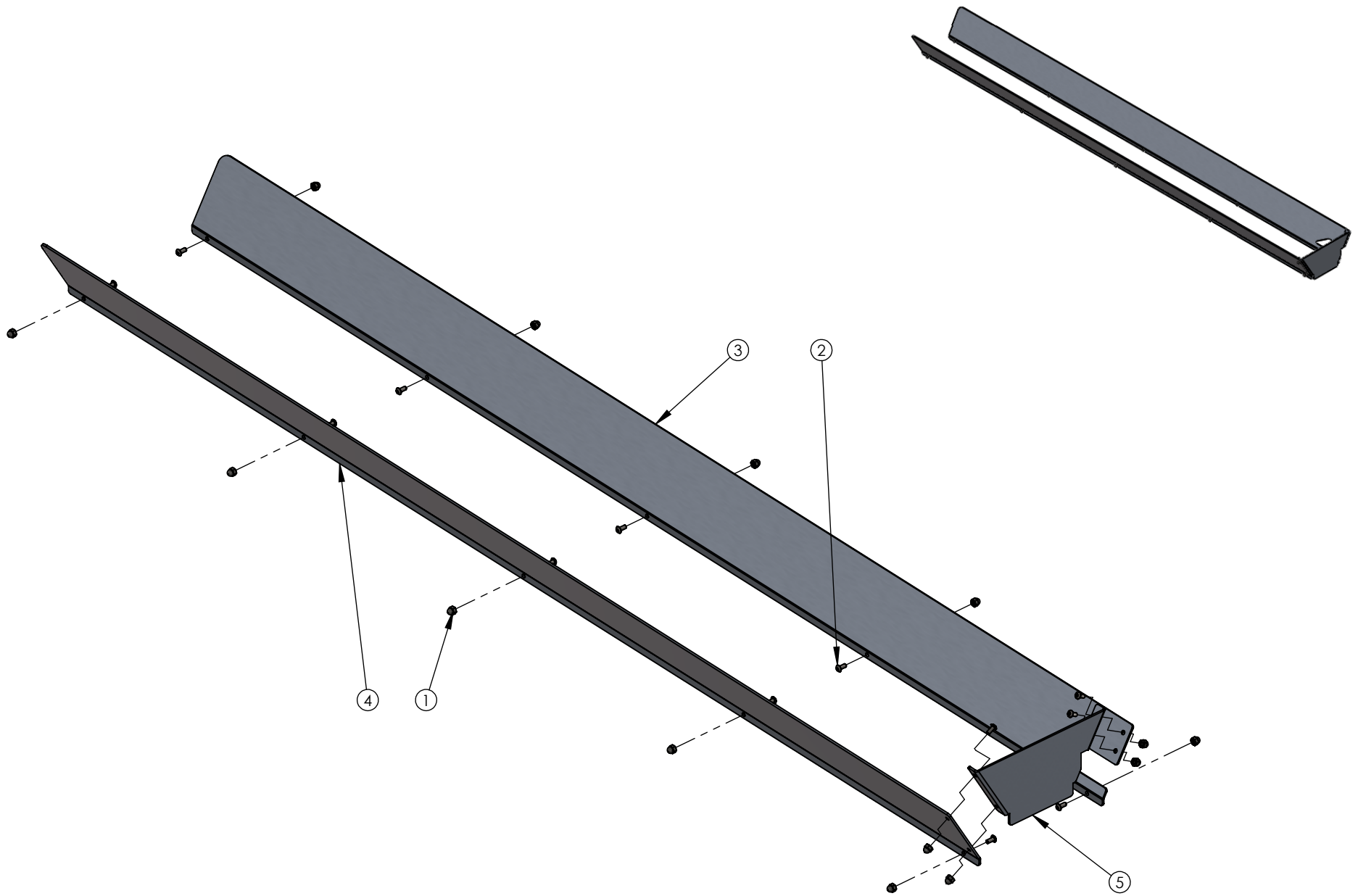

ITEM	PART NO.	DESCRIPTION	QTY.
1	13-0344-00	NUT ACORN SELF LOCK SS #8-32	14
2	13-0345-00	BOLT BHSCS SS #8-32 X 3/8	14
3	26-0023-00	FEED CONVEYOR FLARE PLATE RH	1
4	26-0024-00	FEED CONVEYOR FLARE PLATE LH	1
5	26-0025-00	FEED CONVEYOR END PLATE	1



TITLE:
FEED CONVEYOR FLARE ASSY

DWG. NO.
26-0022-00

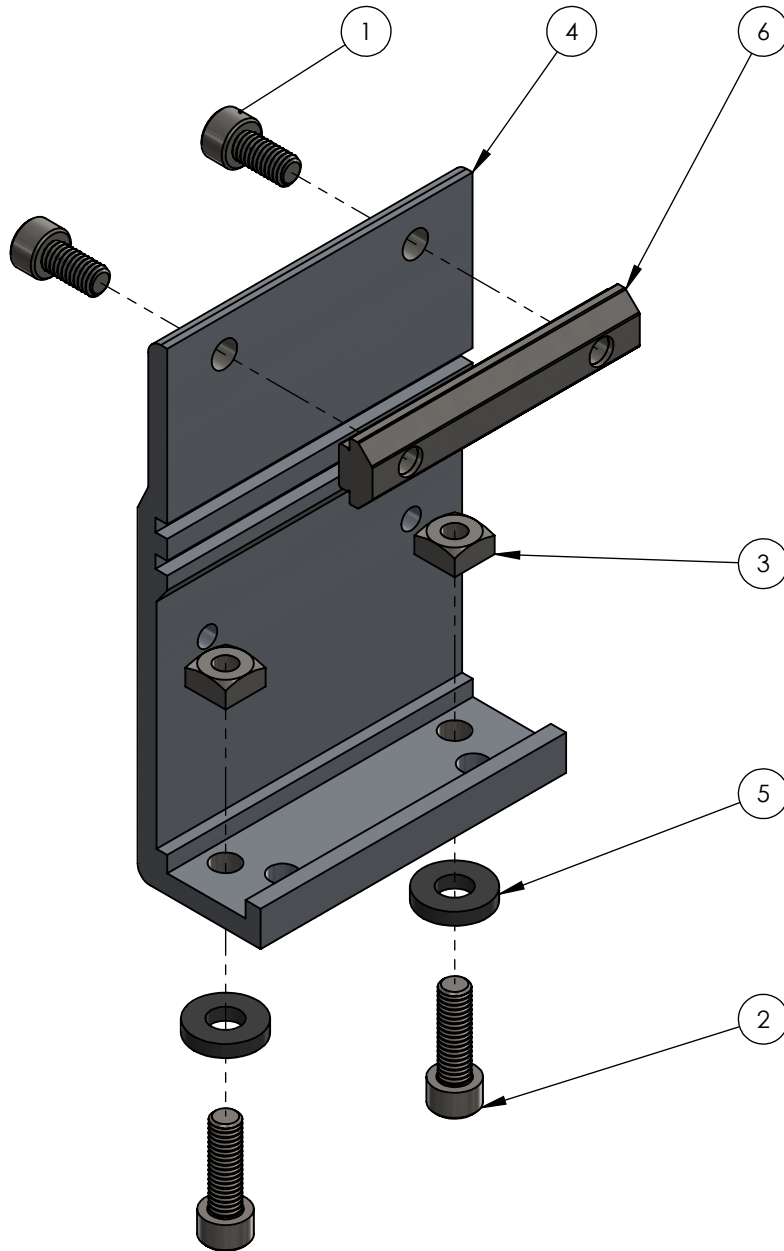

ITEM	PART NO.	DESCRIPTION	QTY.
1	13-0094-00	BOLT HSHCS ZP M6-1.0 X 12MM	2
2	13-0159-00	BOLT SHCS ZP M6-1 X 20MM	2
3	13-0160-00	NUT SQUARE ZP M6-1 X 5MM	2
4	26-0038-00	MOUNTING BRACKET	1
5	26-0039-00	WASHER THICK STEEL 1/4" BLACK	2
6	26-0050-00	2 HOLE T-BAR	1



TITLE:
CONVEYOR TO LEG STAND MOUNTING PACKAGE

DWG. NO.
26-0037-00

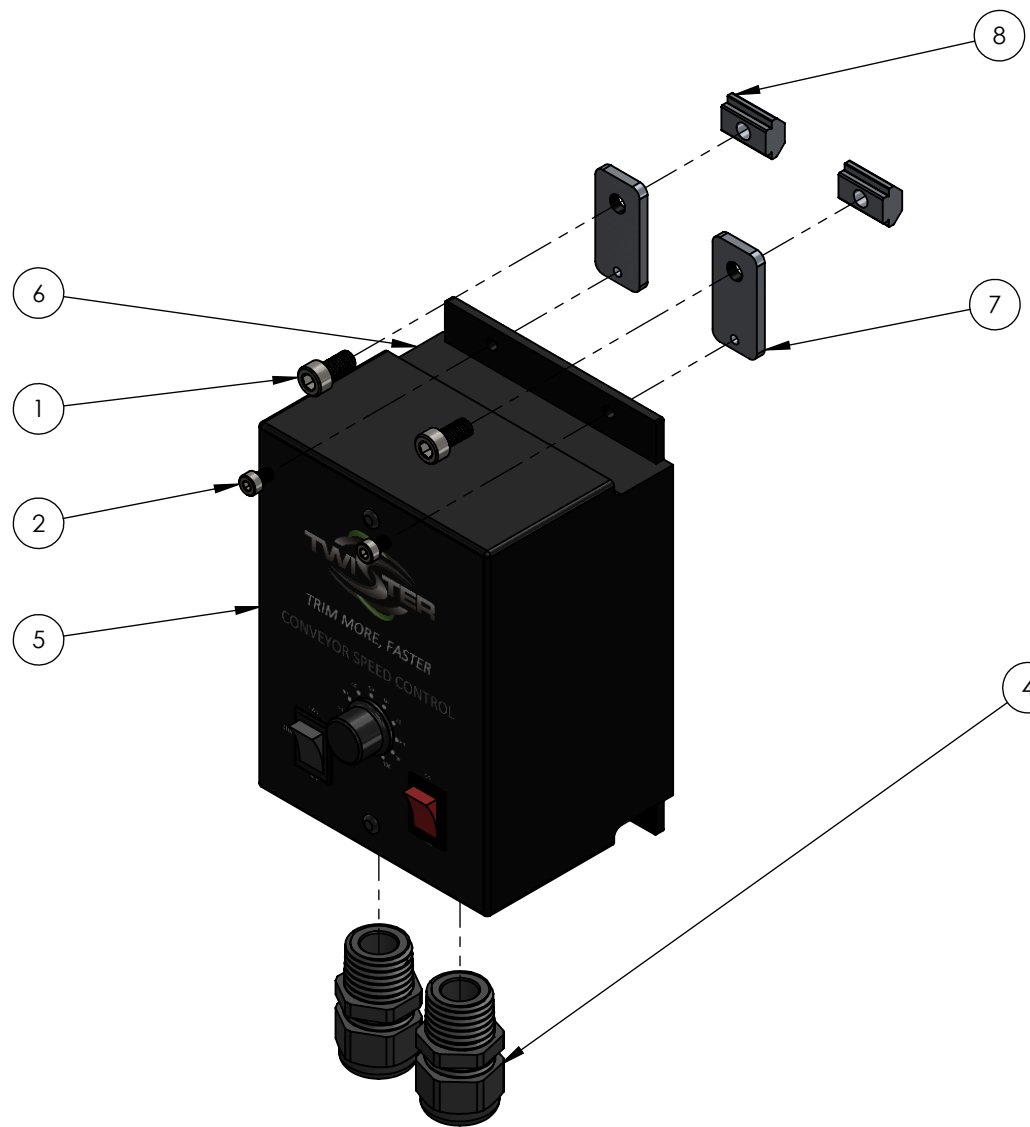

NOTE: ATTACH JUMPER CABLE TO VFD FOR CONVERSION TO 115V

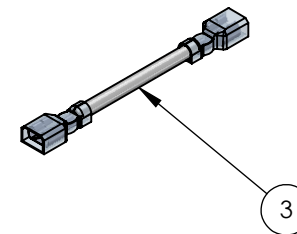

ITEM	PART NO.	DESCRIPTION	QTY.
1	13-0094-00	BOLT HSHCS ZP M6-1.0 X 12MM	2
2	13-0095-00	BOLT HSHCS ZP M4-0.7 X 6MM	2
3	15-0001-00	CONVEYOR VFD JUMPER CABLE	1
4	15-0086-00	LIQUID TIGHT - LARGE 3216	2
5	21-0098-00	DECAL, CONVEYOR AC MOTOR DRIVE - LEXEDGE	1
6	26-0005-00	CONVEYOR MOTOR DRIVE 1/4 HP 115/230V	1
7	26-0015-00	CONVEYOR MOTOR DRIVE MOUNTING CLIP	2
8	26-0018-00	SINGLE HOLE MOUNTING T-BAR	2



TITLE:
CONVEYOR VFD ASSEMBLY

DWG. NO.
26-0046-00

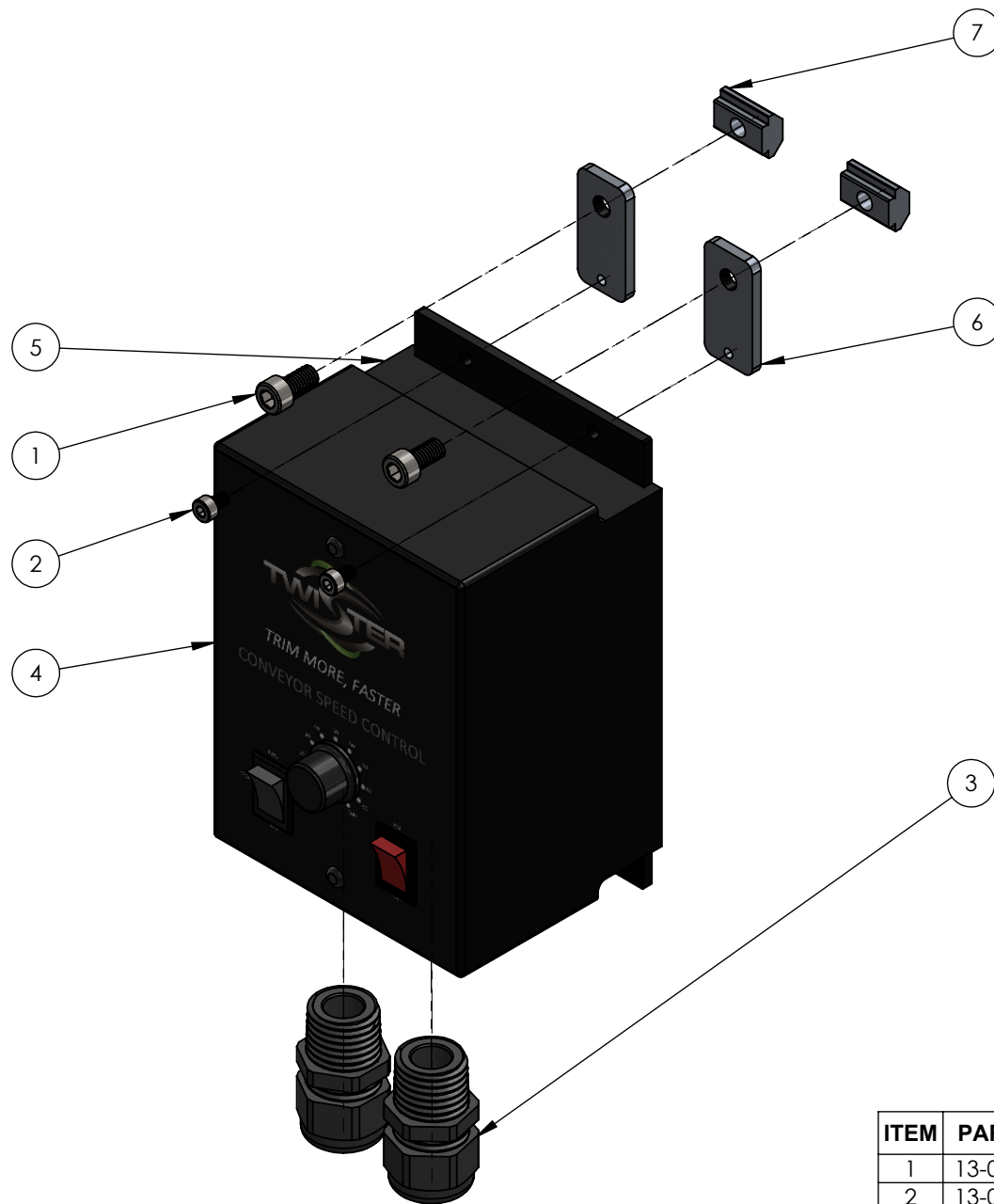

ITEM	PART NO.	DESCRIPTION	QTY.
1	13-0094-00	BOLT HSHCS ZP M6-1.0 X 12MM	2
2	13-0095-00	BOLT HSHCS ZP M4-0.7 X 6MM	2
3	15-0086-00	LIQUID TIGHT - LARGE 3216	2
4	21-0098-00	DECAL, CONVEYOR AC MOTOR DRIVE - LEXEDGE	1
5	26-0005-00	CONVEYOR MOTOR DRIVE 1/4 HP 115/230V	1
6	26-0015-00	CONVEYOR MOTOR DRIVE MOUNTING CLIP	2
7	26-0018-00	SINGLE HOLE MOUNTING T-BAR	2



TITLE:
CONVEYOR VFD ASSEMBLY EURO

DWG. NO.
26-0046E-00

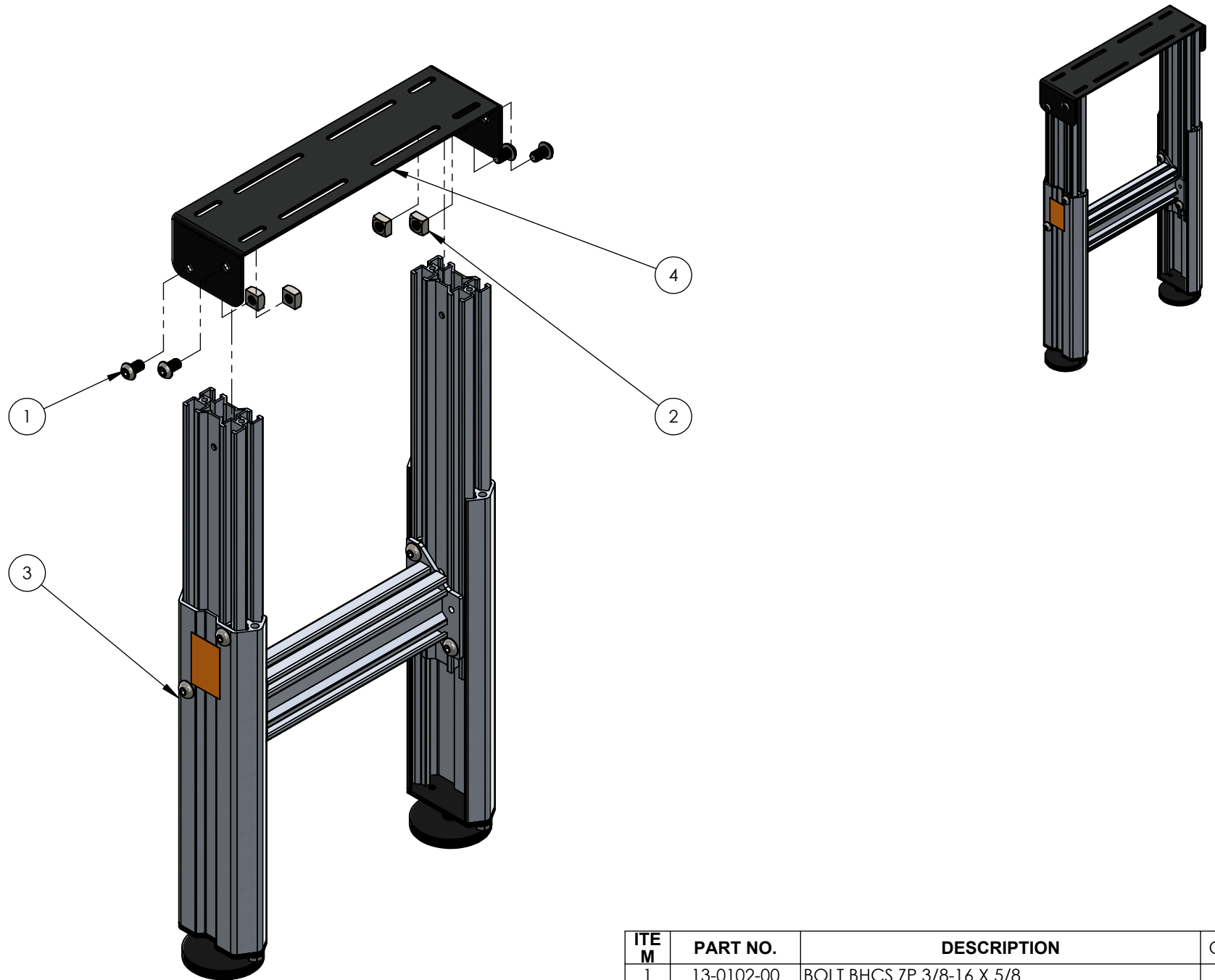

ITEM	PART NO.	DESCRIPTION	QTY.
1	13-0102-00	BOLT BHCS ZP 3/8-16 X 5/8	4
2	13-0103-00	NUT SQUARE ZP 3/8-16 X 5/16	4
3	26-0016-00	FEED CONVEYOR ADJ HEIGHT STAND (24" - 36")	1
4	26-0031-00	CONVEYOR STAND TOP BRACKET	1



TITLE:
FEED CONVEYOR SUPPORT STAND ASSY

DWG. NO.
26-0044-00

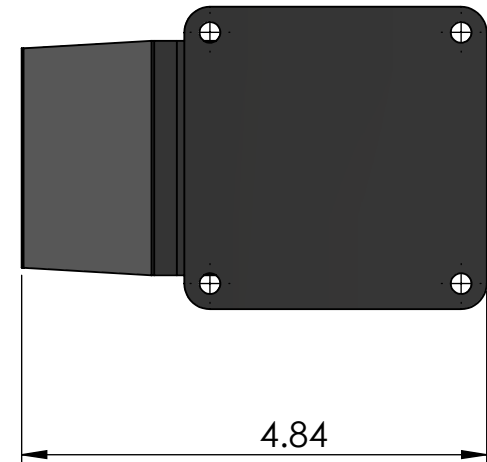
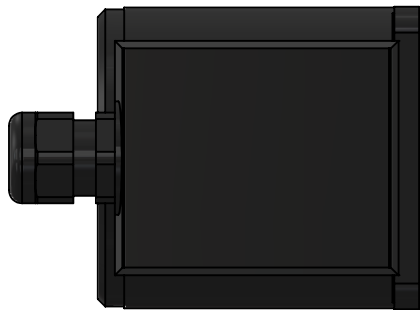
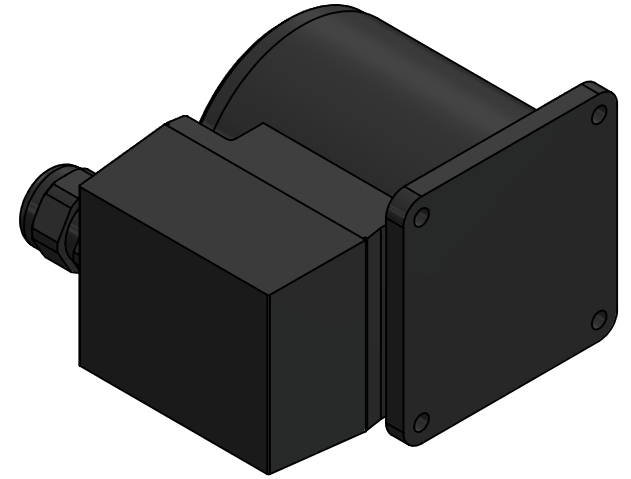
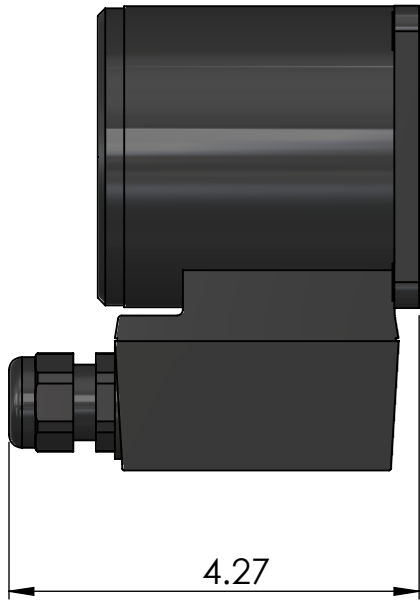

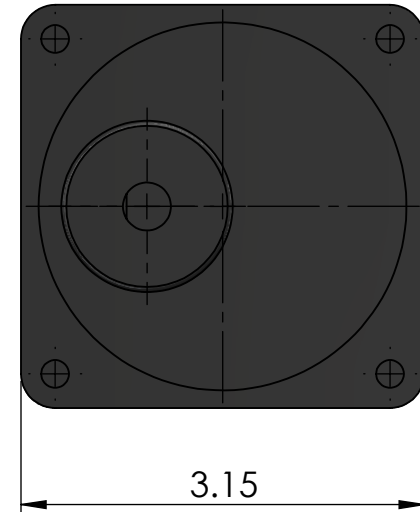
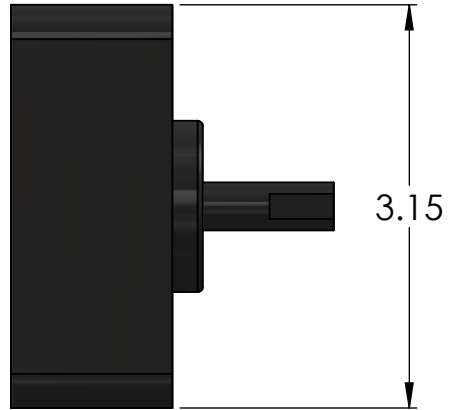
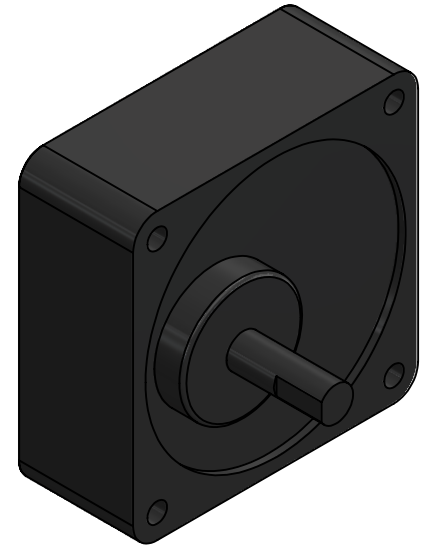
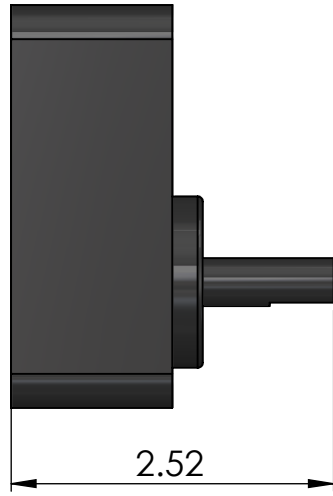

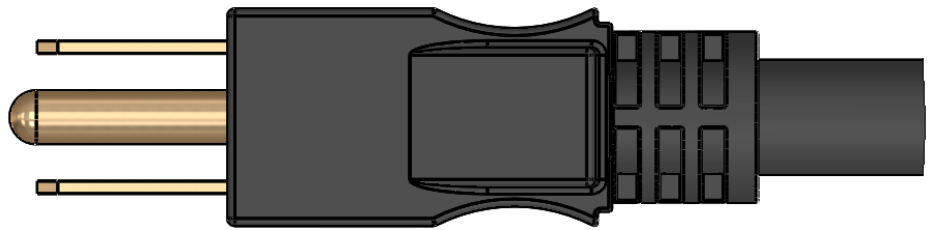
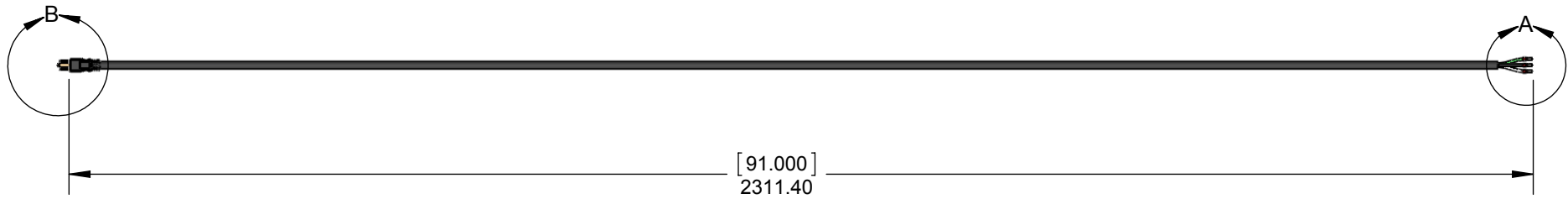

DETAIL B
SCALE 1.5 : 1

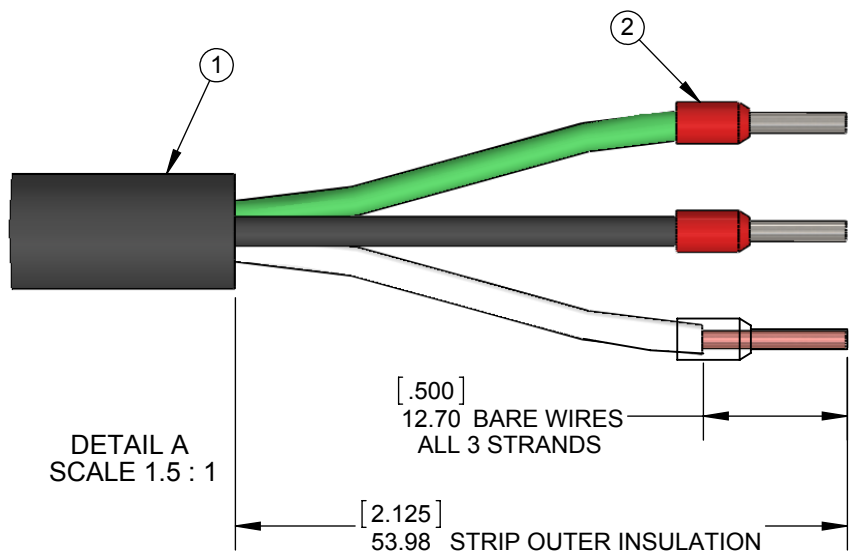

DETAIL A
SCALE 1.5 : 1

ITEM	PART NO.	DESCRIPTION	QTY
1	12-0015-00	POWER CORD 183 AWG w 3-PRONG PLUG	1
2	15-0118-00	WIRE FERRULE 18AWG RED	3

UNLESS OTHERWISE SPECIFIED:		NAME	DATE
DIMENSIONS ARE IN MILLIMETERS [BRACKETED DIMS] ARE IN INCHES		DRAWN BY: L WALSH	16/09/2014
TOLERANCES:		CHECKED BY: A MCKELLAR	16/09/2014
LINEAR: MM	ANGULAR:	MATERIAL:	-
X = ± 0.3	X = ± 0.5°	FINISH:	-
X.X = ± 0.15	X.X = ± 0.1°	PART GROUP:	CONVEYORS
X.XX = ± 0.05	X.XX = ± 0.05°	COMMENTS:	
X.XXX = ± 0.025		DEBURR AND BREAK ALL SHARP EDGES	
PROPRIETARY AND CONFIDENTIAL		DO NOT SCALE DRAWING	
THE INFORMATION CONTAINED IN THIS DRAWING IS THE SOLE PROPERTY OF KEIRTON MANUFACTURING LTD. ANY REPRODUCTION IN PART OR AS A WHOLE WITHOUT THE WRITTEN PERMISSION OF KEIRTON MANUFACTURING LTD. IS PROHIBITED.		SIZE	DWG. NO.
		A	26-0014-00
		SCALE: 1:10	REV
			SHEET 1 OF 1

REVISIONS			
REV	ECN	DESCRIPTION	APPROVED

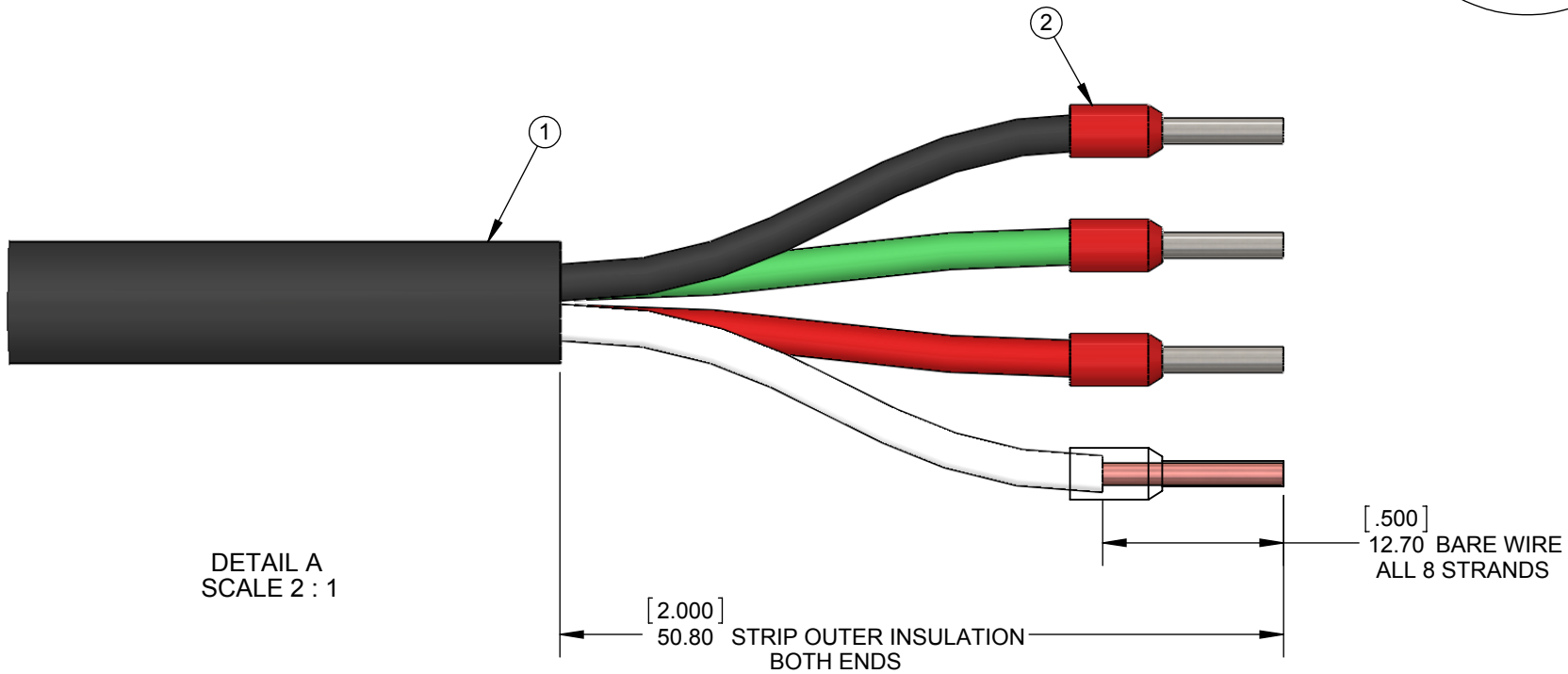
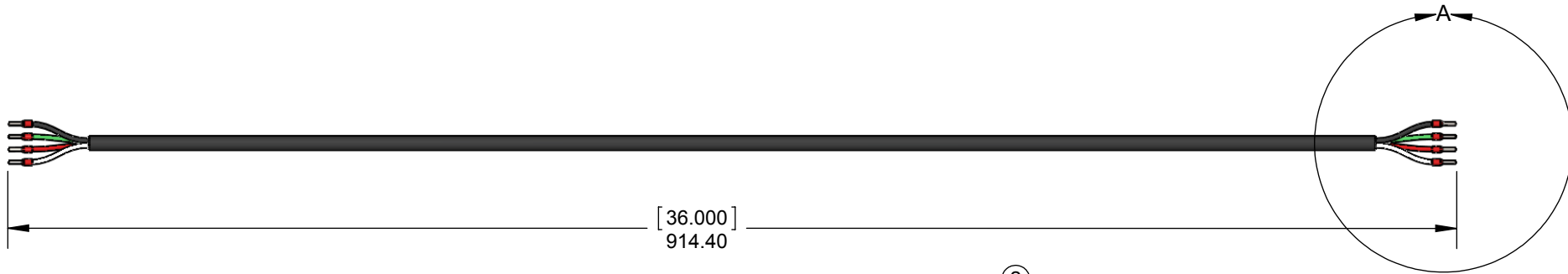

DETAIL A
SCALE 2 : 1

ITEM	PART NO.	DESCRIPTION	QTY
1	12-0016-00	POWER CORD SJEOW18-04-LL 18-4C SJEOW BLK	1
2	15-0118-00	WIRE FERRULE 18AWG RED	8

UNLESS OTHERWISE SPECIFIED:			NAME	DATE
DIMENSIONS ARE IN MILLIMETERS [BRACKETED DIMS] ARE IN INCHES		DRAWN BY:	L WALSH	16/09/2014
TOLERANCES:		CHECKED BY:	A MCKELLAR	16/09/2014
LINEAR: MM	ANGULAR:	MATERIAL:	-	
X = ± 0.3	X = ± 0.5°	FINISH:	-	
X.X = ± 0.15	X.X = ± 0.1°	PART GROUP:	CONVEYORS	
X.XX = ± 0.05	X.XX = ± 0.05°	COMMENTS:	DEBURR AND BREAK ALL SHARP EDGES	
X.XXX = ± 0.025		DO NOT SCALE DRAWING	SIZE	DWG. NO.
PROPRIETARY AND CONFIDENTIAL <small>THE INFORMATION CONTAINED IN THIS DRAWING IS THE SOLE PROPERTY OF KEIRTON MANUFACTURING LTD. ANY REPRODUCTION IN PART OR AS A WHOLE WITHOUT THE WRITTEN PERMISSION OF KEIRTON MANUFACTURING LTD. IS PROHIBITED.</small>			A	26-0017-00
			SCALE: 1:4	REV
				1 OF 1

REVISIONS			
REV	ECN	DESCRIPTION	APPROVED