



MOLECULAR PROPERTY SPECTROMETER™ (MPS™) EXTENDED RANGE METHANE GAS SENSOR USER MANUAL



Notices

SM-UM-0009-03

Copyright © 2018-2022 Nevada Nanotech Systems Inc. All rights reserved.

1395 Greg Street, Suite 102

Sparks, Nevada 89431

All Rights Reserved

This publication is protected by copyright and all rights are reserved. No part of it may be reproduced or transmitted by any means or in any form, without prior consent in writing from NevadaNano.

The information in this document has been carefully checked and is believed to be accurate. However, changes are made periodically. These changes are incorporated in the newer publication editions. NevadaNano may improve and/or change products described in this publication at any time. Due to continuing system improvements, NevadaNano is not responsible for inaccurate information which may appear in this manual. For the latest product updates, consult the NevadaNano web site at www.nevadanano.com. In no event will NevadaNano be liable for direct, indirect, special exemplary, incidental, or consequential damages resulting from any defect or omission in this document, even if advised of the possibility of such damages.

In the interest of continued product development, NevadaNano reserves the right to make improvements in this document and make the products it describes at any time, without notices or obligation.

The Molecule logo is a trademark of Nevada Nanotech Systems Inc. Use of the logos for commercial purposes without the prior written permission of NevadaNano may constitute trademark infringement and unfair competition in violation of federal and state laws.

NevadaNano, the Molecule logo, Molecular Property Spectrometer, and MPS are trademarks of Nevada Nanotech Systems Inc.

Other trademarks and trade names may be used in the document to refer to either the entities claiming the marks and names or their products. Nevada Nanotech Systems Inc. disclaims any proprietary interest in trademarks and trade names other than its own.



Please Recycle

Shipping materials are recyclable. Please save them for later use, or dispose of them appropriately.

Contents

1. How the MPS Extended Range Methane Gas Sensor Works	4
2. Communicating with the Sensor	4
2.1. Serial (UART) Communication	4
2.1.1. Data Representation	5
2.1.2. Protocol Specification	5
2.1.3. Checksum Calculation	7
2.1.4. Startup and Measurement Sequence	8

2.1.5. Command Table	12
2.1.6. Command Descriptions	12
3. Testing the MPS Extended Range Methane Gas Sensor	15
4. Electromechanical Integration	17
4.1. Powering the MPS.....	19
4.2. Hazardous Locations and System Integration	20
5. Warranty information.....	20
5.1. MPS Extended Range Methane Gas Sensor Standard Limited Warranty	20

Version	Issue Date (DD/MM/YYYY)	Change
SM-UM-0009-01	16/03/2022	First edition.
SM-UM-0009-02	29/03/2022	Updated command table and Sensor Info. command
SM-UM-0009-03	23/05/2022	Added warranty section; added information pertaining to the low-power sensor version

the MPS Extended Range Methane Gas Sensor Works

The MPS Extended Range Methane Gas Sensor and MPS Extended Range Low Power Gas Sensor are designed and optimized for open-air detection of methane and natural gas plumes over a full range of concentrations, from 50 to 1,000,000 ppm. In field testing, the sensor has detected methane emitted at a rate of 2 standard cubic feet per hour (SCFH) at distances up to 10 meters with nominal false positive readings over weeks of outdoor operation. Onboard sensor algorithms utilize a smart, variable lower detection limit, updated every sensor cycle, based on “live” sensor conditions.

The MPS is a micro-machined membrane with an embedded Joule heater and resistance thermometer. The MEMS transducer is mounted on a PCB and packaged inside a filtered enclosure that is permeable to ambient air. Presence of a methane causes changes in the thermodynamic properties of the air/gas mixture; these properties are measured by the transducer and processed by patent-pending algorithms to report an accurate concentration.

The smart sensor is intrinsically safe, robust, and extremely poison-resistant. It has built-in environmental compensation and performs constant self-testing for fail-safe operation. Sensor readings are output on a standard digital bus—no added electronics are required. With a 5-year lifetime and no calibration required, the MPS Extended Range Methane Gas Sensor and the MPS Extended Range Low Power Sensor deliver industry-leading performance and a low cost of ownership.

The sensor is not suited for safety applications or for detection of gradually accumulating concentrations (e.g. slow leaks into confined, poorly ventilated spaces).

To achieve the sensor’s notable combination of high sensitivity with nominal false positives, proper mechanical integration is required. Refer to Section 4 “Electromechanical Integration.”

2. Communicating with the Sensor

This section describes the software interface requirements for the sensor and will be useful to system integrators when designing the sensor assembly into a final product.

The method of communicating with the sensor is over the serial interface using the UART (Universal Asynchronous Receiver/Transmitter) protocol. Section 2.1 provides the necessary information for communicating using UART.

2.1. Serial (UART) Communication

Communication with the system over the serial interface (UART) will allow an external user or system to execute the commands provided in the Command Table in Section 2.1.5. Users may also refer to the Command Descriptions in Section 2.1.6 for usage descriptions.

Serial connection parameters:

Parameter	Size
Baud Rate	38400
Data Size	8 bits
Parity	None
Stop Bit	1 bit

2.1.1. Data Representation

All integer values (16 bits or 32 bits) are represented in Little Endian format (LSB first). This means when an integer is transmitted on the serial interface, the least significant byte (LSB) is transmitted first and the most significant byte (MSB) is transmitted last. Floating point numbers are represented in IEEE 754 format.

2.1.2. Protocol Specification

Communication to and from the sensor is made up of “packets.” The communication paradigm is that of “request” and “reply.” An external host sends a “request” packet to the sensor. The sensor returns a “reply” packet to the external host. A packet consists of a fixed size “header” and a variable length “payload.” It is possible for a packet to have no payload (length of zero) where a packet contains only a header. The payload, if any, typically consists of “parameters” for a request or “result” for a reply. Even when a reply does not contain any result, a reply is still sent with the header as an acknowledgement of the request.

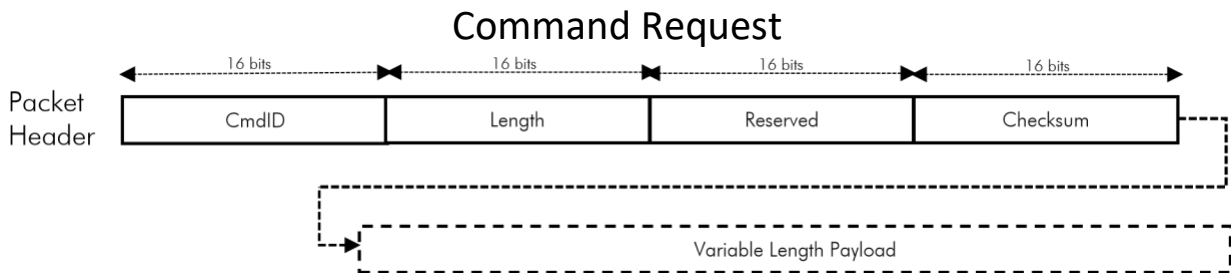

Figure 1: Request Packet Structure

The Request Packet (Figure 1) consists of the following fields:

Field	Size	Description
CmdID	2 Bytes	Command ID of this request (see Command Table in Section

		2.1.5). Although CmdID uses only 1 byte, it is extended to 2 bytes in the Request Header for alignment purposes.
Length	2 Bytes	Length of the Payload (0 if no payload)
Reserved	2 Bytes	Reserved for future use (zero filled)
Checksum	2 Bytes	Checksum of the entire packet
Variable Length Payload	variable	Command parameters for this request

Command Reply

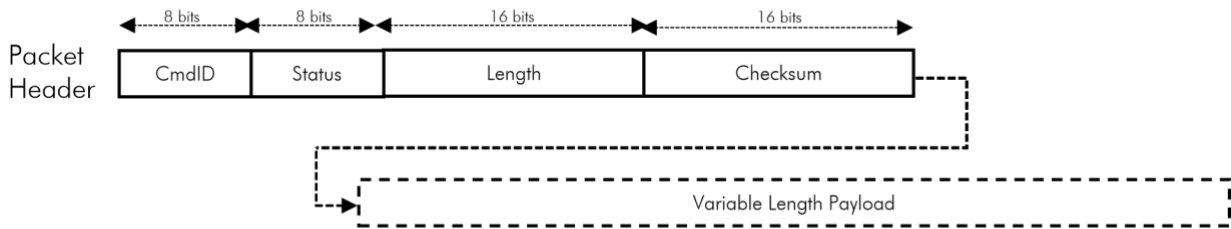

Figure 2: Reply Packet Structure

The Reply Packet (Figure 2) consists of the following fields:

Field	Size	Description
CmdID	1 Byte	Command ID (should match the original request)
Status	1 Byte	Return status of the request
Length	2 Bytes	Length of the Payload (0 if no payload)
Checksum	2 Bytes	Checksum of the entire packet
Variable Length Payload	variable	Command parameters for this request

The Status field consists of the following possible return values:

Fault	Fault Message	Explanation	Concentration Output (ppm)	User action
0x00	OK	MPS is operating normally and has no errors	Normal	None
0x01	CRC_FAILED	Transmitted data failed checksum	N/A	Verify checksum calculation is correct. See Section 2.1.3.
0x02	BAD_PARAM	Illegal or bad parameters specified	N/A	Verify parameter given in command is correct.
0x03	EXE_FAILED	Execution of command failed	N/A	Contact support.
0x04	NO_MEM	Insufficient memory for operation	N/A	Contact support.

0x05	UNKNOWN_CMD	Unknown Command ID specified	N/A	Verify Command ID is correct. See Section 2.1.5.
0x07	INCOMPLETE_COMMAND	Incomplete or truncated command	N/A	Verify entire packet header and payload (if any) is fully sent.
0x22	HW_ERR_VREF	Voltage out of range	-100 ppm	Supply 3.3-5.0 \pm 5% VDC. If this error persists for more than 5 cycles, this error will latch until the sensor is power cycled and supplied correct voltage
0x24	HW_ENV_SNSR_MALFUNCTION	Environmental sensor malfunction	-100 ppm	Occurrence of this error will latch the sensor in this condition and no longer allow normal operation. Contact support.
0x25	HW_ERR_MCU	Microcontroller error	-100 ppm	Contact support.
0x26	HW_SENSOR_INITIALIZATION	Sensor in initialization mode (1 cycle)	-100 ppm	Wait 1 cycle (~2 sec for Extended Range, or ~4 sec for Extended Range Low Power version) for sensor to initialize.
0x32	HW_SENSOR_MALFUNCTION	Gas sensing element malfunction	-100 ppm	Contact support.

2.1.3. Checksum Calculation

The algorithm for checksum calculation is that of 16-bit CRC CCITT with start byte 0xFFFF. Checksum is computed over the entire packet (header and payload). The checksum field in the header is initialized with zeros before computing checksum. If there is no payload, checksum is computed against the header only. The following sample C code can be used to calculate the checksum for a buffer of a given size:

```
#include <stdlib.h>
#include <stdint.h>

static uint16_t crc_table[256] = {
    0x0000, 0x1021, 0x2042, 0x3063, 0x4084, 0x50a5, 0x60c6, 0x70e7,
    0x8108, 0x9129, 0xa14a, 0xb16b, 0xc18c, 0xd1ad, 0xe1ce, 0xf1ef,
    0x1231, 0x0210, 0x3273, 0x2252, 0x52b5, 0x4294, 0x72f7, 0x62d6,
    0x9339, 0x8318, 0xb37b, 0xa35a, 0xd3bd, 0xc39c, 0xf3ff, 0xe3de,
    0x2462, 0x3443, 0x0420, 0x1401, 0x64e6, 0x74c7, 0x44a4, 0x5485,
    0xa56a, 0xb54b, 0x8528, 0x9509, 0xe5ee, 0xf5cf, 0xc5ac, 0xd58d,
    0x3653, 0x2672, 0x1611, 0x0630, 0x76d7, 0x66f6, 0x5695, 0x46b4,
    0xb75b, 0xa77a, 0x9719, 0x8738, 0xf7df, 0xe7fe, 0xd79d, 0xc7bc,
    0x48c4, 0x58e5, 0x6886, 0x78a7, 0x0840, 0x1861, 0x2802, 0x3823,
    0xc9cc, 0xd9ed, 0xe98e, 0xf9af, 0x8948, 0x9969, 0xa90a, 0xb92b,
    0x5af5, 0x4ad4, 0x7ab7, 0x6a96, 0x1a71, 0x0a50, 0x3a33, 0x2a12,
    0xdbfd, 0xcbdc, 0xfbbf, 0xeb9e, 0x9b79, 0x8b58, 0xbb3b, 0xab1a,
    0x6ca6, 0x7c87, 0x4ce4, 0x5cc5, 0x2c22, 0x3c03, 0x0c60, 0x1c41,
    0xedae, 0xfd8f, 0xcdec, 0xddcd, 0xad2a, 0xbd0b, 0x8d68, 0x9d49,
```

```

0x7e97, 0x6eb6, 0x5ed5, 0x4ef4, 0x3e13, 0x2e32, 0x1e51, 0x0e70,
0xff9f, 0xefbe, 0xdfdd, 0xcffc, 0xbf1b, 0xaf3a, 0x9f59, 0x8f78,
0x9188, 0x81a9, 0xb1ca, 0xaleb, 0xd10c, 0xc12d, 0xf14e, 0xe16f,
0x1080, 0x00a1, 0x30c2, 0x20e3, 0x5004, 0x4025, 0x7046, 0x6067,
0x83b9, 0x9398, 0xa3fb, 0xb3da, 0xc33d, 0xd31c, 0xe37f, 0xf35e,
0x02b1, 0x1290, 0x22f3, 0x32d2, 0x4235, 0x5214, 0x6277, 0x7256,
0xb5ea, 0xa5cb, 0x95a8, 0x8589, 0xf56e, 0xe54f, 0xd52c, 0xc50d,
0x34e2, 0x24c3, 0x14a0, 0x0481, 0x7466, 0x6447, 0x5424, 0x4405,
0xa7db, 0xb7fa, 0x8799, 0x97b8, 0xe75f, 0xf77e, 0xc71d, 0xd73c,
0x26d3, 0x36f2, 0x0691, 0x16b0, 0x6657, 0x7676, 0x4615, 0x5634,
0xd94c, 0xc96d, 0xf90e, 0xe92f, 0x99c8, 0x89e9, 0xb98a, 0xa9ab,
0x5844, 0x4865, 0x7806, 0x6827, 0x18c0, 0x08e1, 0x3882, 0x28a3,
0xcb7d, 0xdb5c, 0xeb3f, 0xfb1e, 0x8bf9, 0x9bd8, 0xabbb, 0xbb9a,
0x4a75, 0x5a54, 0x6a37, 0x7a16, 0x0af1, 0x1ad0, 0x2ab3, 0x3a92,
0xfd2e, 0xed0f, 0xdd6c, 0xcd4d, 0xbdaa, 0xad8b, 0x9de8, 0x8dc9,
0x7c26, 0x6c07, 0x5c64, 0x4c45, 0x3ca2, 0x2c83, 0x1ce0, 0x0cc1,
0xef1f, 0xff3e, 0xcf5d, 0xdf7c, 0xaf9b, 0xbfba, 0x8fd9, 0x9ff8,
0x6e17, 0x7e36, 0x4e55, 0x5e74, 0x2e93, 0x3eb2, 0x0ed1, 0x1ef0,
};
uint16_t crc_generate(uint8_t *buffer, size_t length, uint16_t startValue)
{  uint16_t
  crc;  uint8_t
  *p;  int ii;
  crc = startValue;

  for(p = buffer, ii = 0; ii < length; ii++) {
  crc = (crc << 8) ^ crc_table[(crc >> 8) ^ *p];
  p++;
  }
  return crc;
}

```

For more information on how to use the above function, please look at the sample test program “Sample Code” located here: <https://nevadanano.com/downloads>

2.1.4. Startup and Measurement Sequence

Figure 3 describes the recommended steps after powering on the sensor plus the measurement sequence for getting answer data. The major steps consist of the following:

- After powering on the sensor, wait for the sensor to boot up completely (~3 seconds).
- Verify communication channel by asking the sensor for version information.
 - Protocol version can be used to determine available commands, answers or new data. □
 Start measurement in “continuous” mode.
- Wait for the first measurement to complete ◦ This takes ~2 seconds for the Extended Range version, or ~4 seconds for the Extended Range Low Power version.
- Get Answer.
- Repeat process to get answer at the rate shown in Figure 3.

The sensor initializes during the first cycle after powering up. During this period, the sensor output is set to “-100 ppm”, the sensor status is set to HW_SENSOR_INITIALIZATION, and the sensor is not capable of reporting gas concentrations. Once initialization is complete, the sensor is ready to report gas concentrations, and the status is set to 0x00.

The Extended Range Low Power version may have a UART response latency of ~550 ms. This can happen when the UART request coincides with the measurement cycle. One strategy to prevent this latency is to send the Start Measurement command, wait for one second, send the Get Answer command and then continue sending the Get Answer command every 4 seconds thereafter.

Note: The Extended Range sensor takes approximately 2 seconds to calculate and complete a measurement; the Extended Range Low Power version takes approximately 4 seconds. If multiple requests to read the Answer register (0x01) were made within the sensor’s 2-second (or 4-second) window, one might get the same answer. This depends on whether a new measurement is calculated between multiple Answer requests. The MPS Cycle Count (“COUNT”) in the Answer Response is incremented after each measurement is calculated. Therefore, when processing an “answer,” one should compare the COUNT value in the answer against the COUNT value from the previous answer. If the COUNT value did not increment, this a repeated answer. If the COUNT value incremented, this is a new answer from the latest measurement cycle. When continuous measurement is stopped and restarted, the COUNT value resets to 1 with the first measurement.

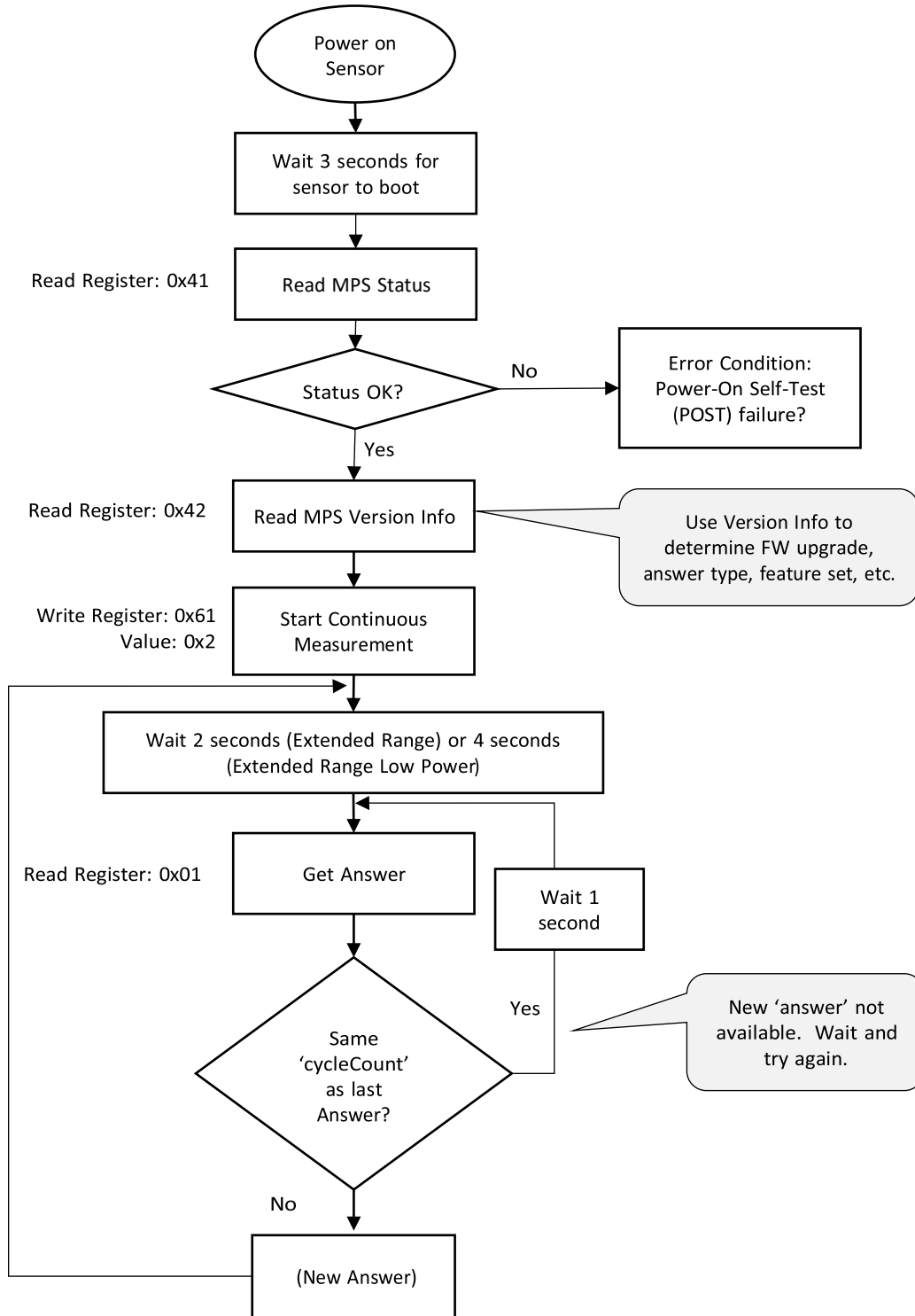
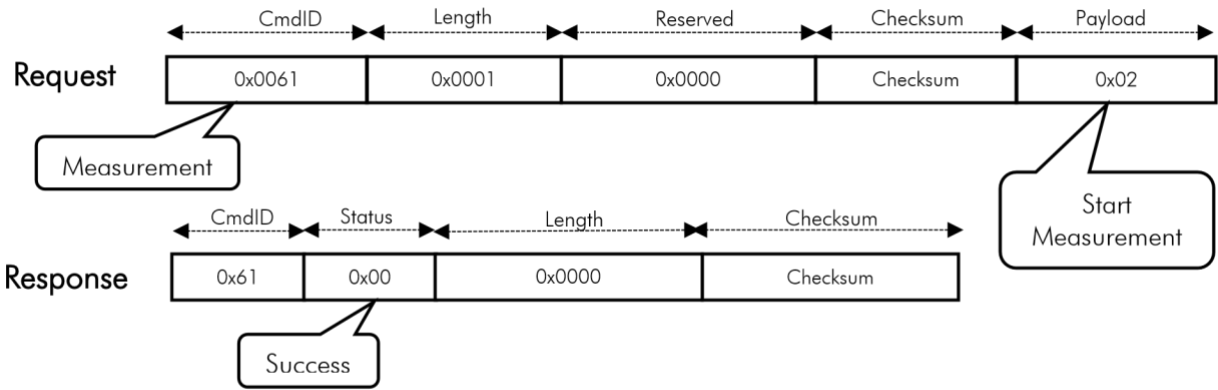

Figure 3: Startup and Measurement Sequence

Figure 4 describes sample Request and Response packets for the Perform Measurement and GetAnswer Vector sequences.

Perform Measurement



Get Answer Vector

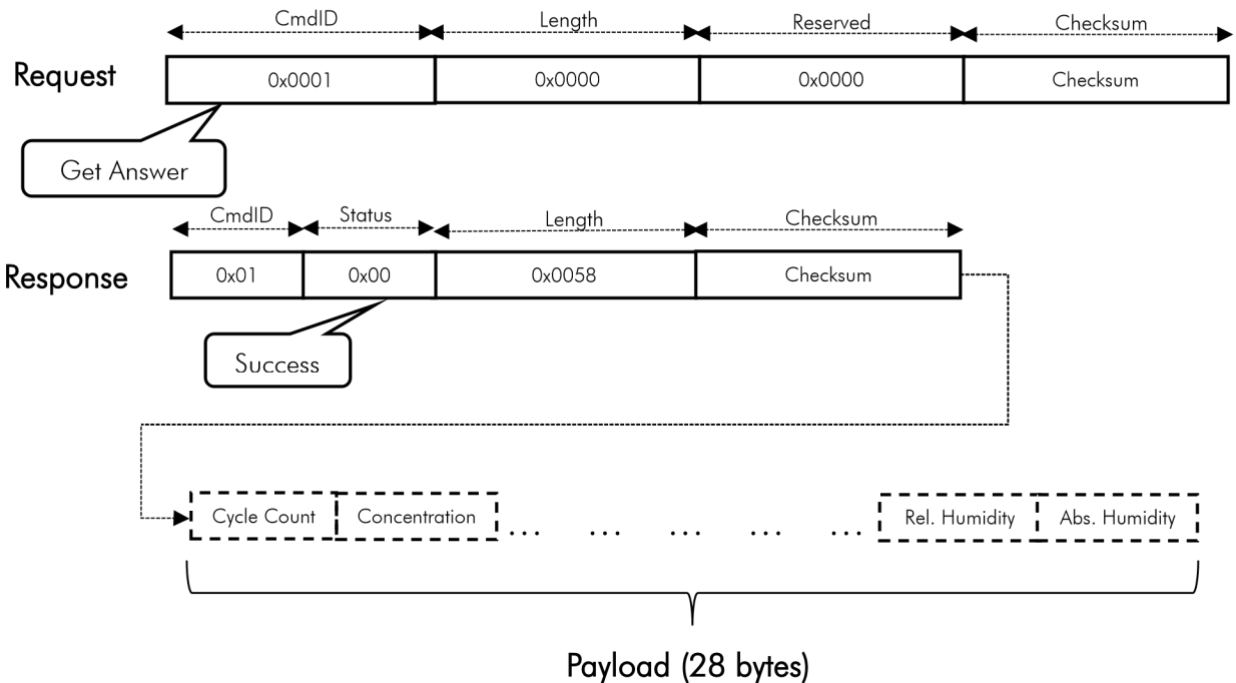

Figure 4: Sample Request and Response Packets for Performing Measurement and Get Answer Vector

Command Table

Hex Code	Command ID	Payload Length [bytes]		Request Packet (Little-Endian Format)				
		Request	Response	CmdID	Length	Reserved	Calculated Checksum*	Payload
0x01	ANSWER	0	28	0x01 0x00	0x00 0x00	0x00 0x00	0xed 0x76	null
0x03	CONC	0	4	0x03 0x00	0x00 0x00	0x00 0x00	0x4b 0xf9	null
0x04	ID	0	4	0x04 0x00	0x00 0x00	0x00 0x00	0x53 0x3e	null
0x21	TEMP	0	4	0x21 0x00	0x00 0x00	0x00 0x00	0x85 0x0d	null
0x22	PRES	0	4	0x22 0x00	0x00 0x00	0x00 0x00	0xf0 0xc5	null
0x23	REL_HUM	0	4	0x23 0x00	0x00 0x00	0x00 0x00	0x23 0x82	null
0x24	ABS_HUM	0	4	0x24 0x00	0x00 0x00	0x00 0x00	0x3b 0x45	null
0x41	STATUS	0	1	0x41 0x00	0x00 0x00	0x00 0x00	0x3d 0x80	null
0x42	VERSION	0	8	0x42 0x00	0x00 0x00	0x00 0x00	0x48 0x48	null
0x43	SENSOR_INFO	0	100	0x43 0x00	0x00 0x00	0x00 0x00	0x9b 0x0f	null
0x61	MEAS	1	0	0x61 0x00	0x01 0x00	0x00 0x00	0x57 0x93	0x02
0x61	MEAS	1	0	0x61 0x00	0x01 0x00	0x00 0x00	0x35 0xb7	0x22
0x61	MEAS	1	0	0x61 0x00	0x01 0x00	0x00 0x00	0x76 0x83	0x03
0x62	RESET	0	0	0x62 0x00	0x00 0x00	0x00 0x00	0x20 0x33	null

*Checksum is calculated from the example shown in this table. Refer to Section 2.1.3 for checksum calculation.

2.1.6. Command Descriptions

1. Command 0x01 – ANSWER – Read Complete Answer

Description: Returns a complete answer in one read operation.

Parameters: N/A

Response: CYCLE_COUNT 32-bit unsigned value. Cycle Number of this measurement (incremented after each measurement)

CONC 32-bit floating point value. Methane gas concentration [ppm]

ID 32-bit unsigned value. Gas ID.

See “Command 0x04 – ID” for descriptions of Gas ID values.

TEMP 32-bit floating point value. Ambient temperature [°C]

PRESSURE 32-bit floating point value. Ambient pressure [kPa]

REL_HUM 32-bit floating point value. Ambient relative humidity [%RH]

ABS_HUM 32-bit floating point value. Ambient absolute humidity [g_3]
m

2. Command 0x03 – CONC – Read Methane Gas Concentration

Description: Returns methane gas concentration (ppm) as measured by the MPS.

Parameters: N/A

Response: CONC 32-bit floating point value. Methane gas concentration (ppm)

Command 0x04 – ID – Read Gas ID

Description: Returns Gas ID as determined by the MPS.
 Parameters: N/A
 Response: ID 32-bit unsigned value. Gas ID.

ID	Description
0	No Gas
3	Methane/Natural Gas
253	Unknown Gas
255	Over Range – Concentration greater than 1,100,000 ppm

4. Command 0x21 – TEMP – Read Temperature

Description: Returns the ambient temperature (°C) as reported by the integrated environmental sensor.
 Parameters: N/A
 Response: TEMP; 32-bit floating point value. Ambient temperature (°C).

5. Command 0x22 – PRES – Read Pressure

Description: Returns the ambient pressure (kPa) as reported by the integrated environmental sensor.
 Parameters: N/A
 Response: PRESSURE; 32-bit floating point value. Ambient pressure (kPa).

6. Command 0x23 – REL_HUM – Read Relative Humidity

Description: Returns the ambient relative humidity (%RH) as reported by the integrated environmental sensor.
 Parameters: N/A
 Response: REL_HUM 32-bit floating point value. Ambient relative humidity (%RH).

7. Command 0x24 – ABS_HUM – Read Absolute Humidity

Description: Returns the ambient absolute humidity (g_3) as calculated by the MPS.
 Parameters: N/A
 Response: ABS_HUM 32-bit floating point value. Ambient absolute humidity (g_3).

m

8. Command 0x41 – STATUS – Read MPS Status

Description: Returns the status of the MPS; refer to Sec. 2.1.2 for status descriptions.
 Parameters: N/A
 Response: STATUS 8-bit unsigned value. Status of MPS

Command 0x42 – VERSION – Read MPS Version Info

Description: Returns the software, hardware and protocol versions of the MPS.

Parameters: N/A

Response: SW_VERSION 8-bit unsigned values. Version is W.X.Y.Z
 HW_VERSION 8-bit unsigned values. Version is W.X
 PROTOCOL_VERSION 8-bit unsigned values. Version is W.X

MPS Version Info																															
1	2	3	4	5	6	7	8	9	10	11	12	13	14	15	16	17	18	19	20	21	22	23	24	25	26	27	28	29	30	31	32
SW Version W [7:0]								SW Version X [7:0]								SW Version Y [7:0]								SW Version Z [7:0]							
33	34	35	36	37	38	39	40	41	42	43	44	45	46	47	48	49	50	51	52	53	54	55	56	57	58	59	60	61	62	63	64
HW Version W [7:0]								HW Version X [7:0]								Protocol Version W [7:0]								Protocol Version X [7:0]							

1. Command 0x43 – SENSOR_INFO – Read MPS Sensor Info

Description: Returns information about the sensor.

Parameters: N/A

Response: SERIAL_NUM Sensor serial number. 32 bytes, zero-padded ASCII string.
 SENSOR_TYPE Sensor type. 32-bit unsigned integer. (Note: “MPS Flammable Gas Sensor” SENSOR_TYPE = 0x03)
 SENSOR_SKU SKU of the sensor. 32 bytes, zero-padded ASCII string.
 CAL_DATE Date of last calibration. 16 bytes, zero-padded ASCII string. Format is MM/DD/YYYY.
 MFG_DATE Date of manufacture. 16 bytes, zero-padded ASCII string. Format is MM/DD/YYYY.

2. Command 0x61 – MEAS – Perform Measurement

Description: Sets the sensing mode (idle, single, or continuous) and “concentration unit” in the measurement.

Parameters: The parameter to the Measurement command is 1 byte in length but consists of two, 4-bit values: Concentration Unit (bits 7:4) and Mode (bits 3:0).

Measurement Value (Byte)	
Conc. Unit [7:4]	Mode [3:0]

The “concentration unit” (bits 7:4 of the measurement byte) is parts-per-million by volume (ppm); this is the unit that will be reported for commands 0x01 and 0x03.

Unit	Name	Description
0x0	PPM	Concentration reported in parts per million.

The measurement mode (bits 3:0 of the measurement byte) consists of the following possible values:

MODE	Name	Description
0x2	MPS_CONT	MPS operates in an autonomous, continuous mode
0x3	MPS_STOP	Stop measurement – no measurements are being taken

Response: N/A

3. Command 0x62 – SHUT_DOWN – Shut down MPS

Description: Prepares the MPS for a shutdown by saving necessary data and states.

Parameters: N/A

Response: N/A

3. Testing the MPS Extended Range Methane Gas Sensor

The MPS Extended Range Methane Gas Sensor and MPS Extended Range Low Power Sensor are designed and optimized for open-air detection of methane and natural gas. The sensor automatically compensates out the effects of humidity, temperature and pressure. Properly assessing sensor performance requires that:

- a) the sensor has been integrated according to the enclosure guidelines specified in Section 5
- b) the sensor is operated where methane is emitted (i.e. leaked) from a point source that is (at least occasionally) upwind from the sensor.

Any operational or experimental setup that does not meet such criteria could result in misleading data, since there are a variety of testing artifacts that can be introduced in conventional laboratory setups.

Unwanted artifacts can be due to:

- The use of compressed gas cylinders and tubing to deliver gas to the sensor. Such pre-mixed cylinders typically contain background “air” that does not properly approximate real air (i.e. it may be missing Argon, and/or Carbon Dioxide, and/or have unnatural ratios of Nitrogen and Oxygen). Further, delivery of gas from compressed gas cylinders can create conditions and transients in humidity, temperature, and pressure which are not possible or likely in the “realworld” environments for which the sensor has been tuned.
- Using environmental chambers, which can create conditions and/or environmental transients not possible or likely in the real use case.

If “real-world” testing is not possible, the best experiments are those which most closely simulate realworld sensor operation. In the case that an artificial test environment must be used, the following guidance can help to mitigate the aforementioned artifacts.

Sudden, wholesale changes to the molecular properties of the sample (i.e. artificial changes which can only be generated in a lab test rig) can lead to inaccurate MPS outputs. This of course excludes changes

due to the presence of methane gas. An example of an inadvisable change (shown in Fig. 5c, 5d) would be alternating between ambient air (which contains argon, carbon dioxide and other trace gases) and methane gas + synthetic "zero air" balance (which contains none of the trace constituent gases in ambient air). To best simulate the real-world application (Fig. 5a) in artificial laboratory testing, the same type of "air" must be used for the background and the carrier of the methane gas for the duration of the test. An example of a proper protocol is shown in Fig. 5b. Using a variation of the "incorrect" procedure will invalidate the accuracy of MPS measurements.

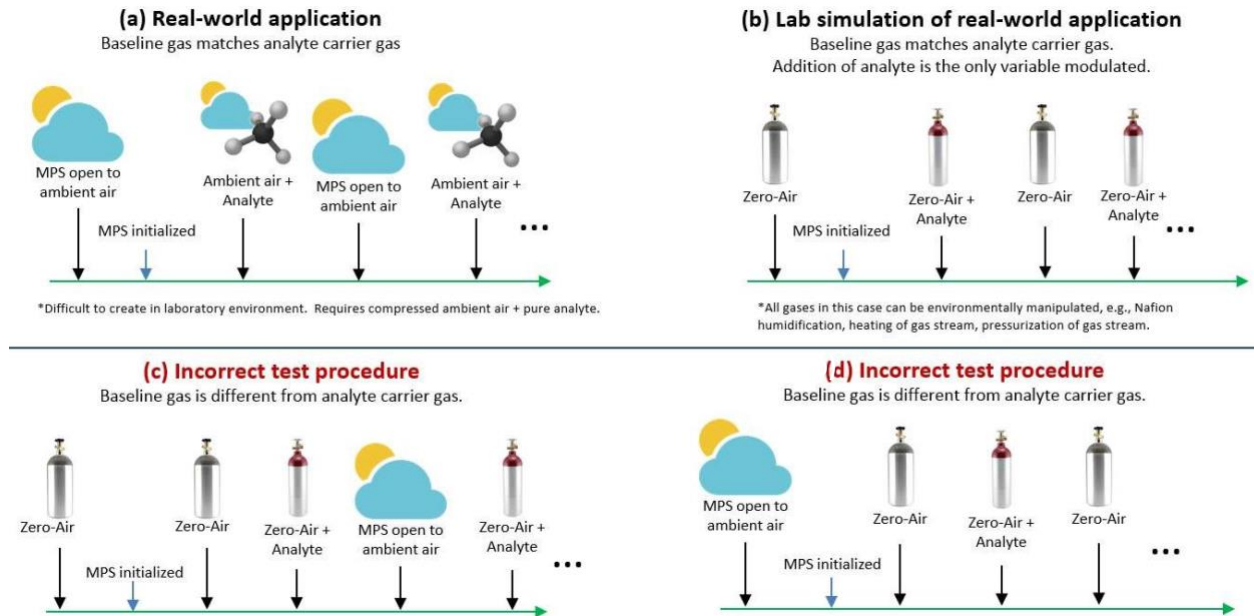

Figure 5: (a) The real-world methane gas leak scenario. (b) The method for simulating the real-world scenario in a laboratory. Incorrect test procedures are shown in (c) and (d); in these cases, the carrier-only condition does not use the same "air" as the carrier + methane gas condition, causing inaccurate results.

A "best practice" for performance testing in a laboratory is to use a humidified zero-air background, followed by a switch to a humidified analyte stream with the same zero-air composition as balance gas, then a switch back to humidified zero-air to clear the test chamber. This better mimics real-world MPS performance, where methane gas is introduced into relatively invariant ambient air (Fig. 6a).

Real World Case

Selected, Artificial (“Laboratory”) Use Cases

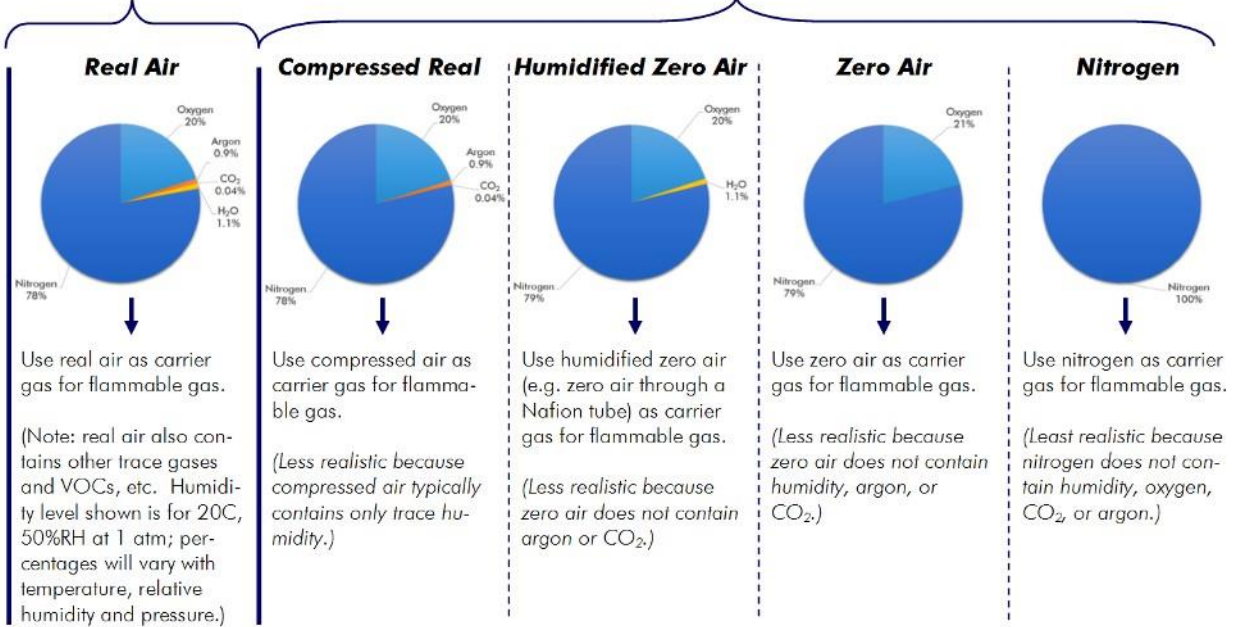

Figure 6: Various “air” options for use as the carrier, or background, gas during methane gas testing.

The best practice is to use one of the options toward the left side of the figure. In addition, do not switch between two different types of “air” during an experiment, as this can produce unwanted (and unrealistic) testing artifacts.

4. Electromechanical Integration

To achieve the sensor’s notable combination of high sensitivity with nominal false positives, proper mechanical integration is required. Following these guidelines ensures proper performance:

- The sensor should be installed so as to face downward inside a cylindrical enclosure with an air inlet facing the ground. The recommended general installation is shown in Figure 9. The inlet diameter, X, should be sized at approximately 14 mm, and the air gap, Z, should be less than 2 mm. Radial spacing, Y, between the sensor and the enclosure should be 1-3 mm. (Note the ~1° draft angle of the “Series 4” type MPS sensor package.) The wall thickness, A, should be 8-10 mm, and B should be approximately 4 mm.

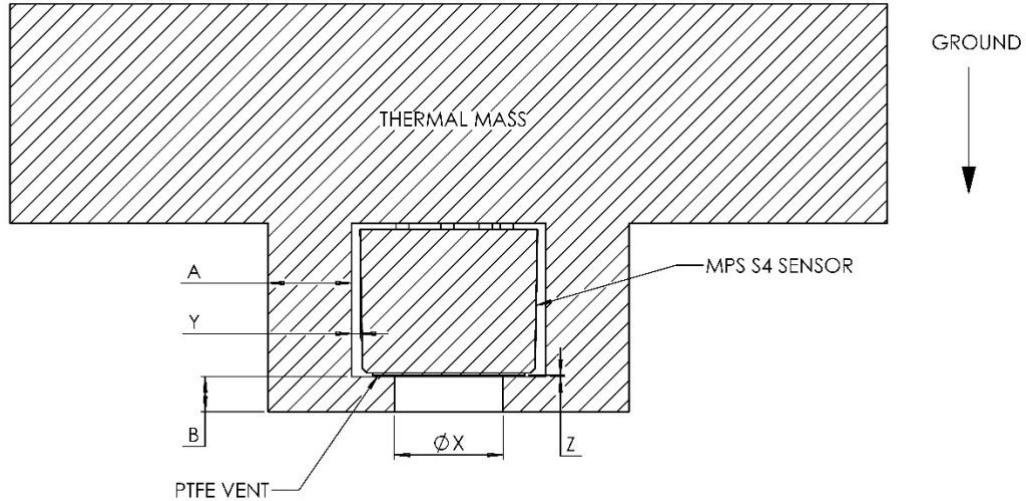

Figure 9: Reference enclosure design.

- A microporous membrane (e.g., Porex PTFE PM21ML) should be attached directly to the sensor's air intake.
- Additionally, it is encouraged that the sensor be electromechanically coupled, via its pins, to a significant thermal mass (e.g., a printed circuit board with potting, batteries, etc.).
- Use an impact- and chemical-resistant plastic material for the enclosure (e.g., Ultem PEI). Lighter colors are preferable to reduce radiant heating effects from ambient sunlight.

The sensor has the same cylindrical shape and dimensions as many industry-standard (catalytic and infrared-type), "4 series" combustible gas sensors and is Intrinsically Safe (IS) certified. To improve water ingress protection, a user may elect to affix a microporous membrane (e.g., Porex PTFE PM21ML) to the sensor intake. The addition of such a membrane may slow the speed of response, dependent upon the gas. Lighter gases (e.g., methane) are relatively unaffected; however, for heavier gases like toluene and xylene, one can expect slower response times and some suppression of reported concentration. The critical dimensions of the sensor are indicated in Figure 10 and the pinout in Figure 11. The mating receptacles are available in distribution, and can be found using Mill-Max P/N: 0384-0-6780-23-27-10-0.

Note: the Analog Out pin (unused), must be left unterminated as an "open" or "no-connect" in the system integrator's PCB design.

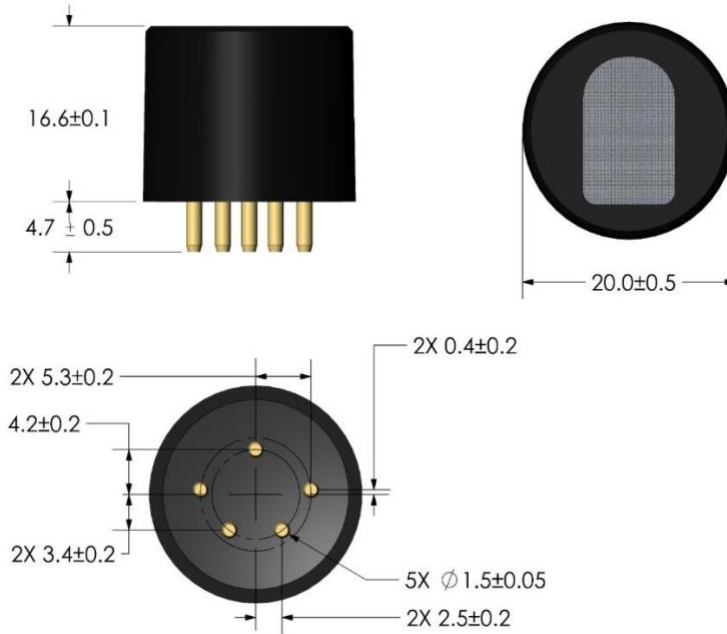

Figure 10: MPS Extended Range Methane Gas Sensor critical dimensions (mm)

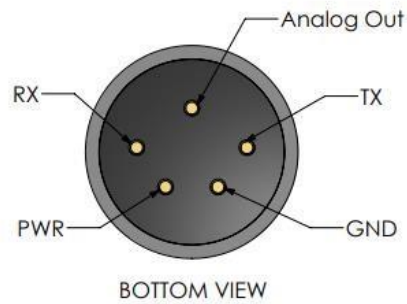

Figure 11: MPS Extended Range Methane Gas Sensor and MPS Extended Range Low Power Methane Gas Sensor electrical pin configuration. (Note, the analog out must be left unterminated as an "open" or "no-connect" in the integrator's PCB design.)

The sensor is a standard "4 series" size – 20 mm ϕ , and 16.6 mm high. The sensor housing is constructed from Ultem PEI plastic. The sensor holds an ATEX-default IP2X rating, and has passed additional testing in accordance with MIL-STD-810G Method 510.5 for dust resistance. The sensor is susceptible to liquid ingress and will not function properly if water or other liquids inundate the sensor chamber.

4.1. Powering the MPS

In powering the MPS sensor, the following criteria need to be met:

- Voltage range must be 3.3-5.0 V \pm 5%
- Ripple and noise should not exceed 50 mV

- The supply must be capable of providing at least 35 mA without appreciable voltage drop
- The voltage rise rate at power up should be greater than 250 μ s per volt from a cold start (that is, when powering up a sensor that has been off for more than 5 seconds)

Achieving the proper voltage rise rate can be accomplished using voltage regulators with “soft-start” capability, though added capacitance (less preferred), or by placing a series resistor between the voltage source and the MPS power pin.

If the voltage rise rate condition above is not met when powering up a sensor that has been off for more than 5 seconds, a small percentage of sensors may power up into a state in which they do not respond to commands or do not generate the proper analog output. If this occurs, shutting power off to the sensor for between 0.5 to 2 seconds and then immediately powering the sensor back on will cause the sensor to recover and power up normally, *even if the voltage rise rate condition above is not met.*

4.2. Hazardous Locations and System Integration

Integrating the MPS into intrinsically safe systems requires additional design consideration. Refer to the MPS Hazardous Locations User Guide (<https://nevadanano.com/downloads>) for information regarding certifications, protection concepts, and entity parameters.

5. Warranty information

The MPS Extended Range Methane Gas Sensor and MPS Extended Range Low Power Gas Sensor carry a 2-year warranty against defects in materials and workmanship, as specified in the Standard Limited Warranty in Section 5.1. The warranty is voided if the sensors are used under conditions other than those specified in the sensor datasheet or this user manual. Please pay particular attention to these things:

- Do not use or otherwise expose the sensor to the following environmental conditions:
 - Temperatures above 90°C or less than -60°C
 - Ambient pressures above 130 kPa or less than 30 kPa
- Do not allow water or other liquids to accumulate inside the sensor
- **Do not solder to the S4 sensor pins**
- Observe the correct supply polarity and voltage ranges

5.1. MPS Extended Range Methane Gas Sensor Standard Limited Warranty

Nevada Nanotech Systems, Inc. warrants its MPS Extended Range Methane Gas Sensor and MPS Extended Range Low Power Gas Sensor, (both referred to hereafter as the Product) manufactured and sold by Nevada Nanotech Systems, Inc. to be free from defects in materials and workmanship for a period of two years from the date of original purchase. This warranty is expressly limited to the original owner who purchases the equipment directly from Nevada Nanotech Systems, Inc. or from an authorized Nevada Nanotech Systems Distributor and is non-transferrable.

To maintain this limited warranty, the product must be operated, used, and maintained in accordance with the conditions specified in the MPS™ Extended Range Methane Gas Sensor Datasheet, the MPS™ Extended Range Low Power Methane Gas Sensor Datasheet the MPS™, the Extended Range Methane Gas Sensor User Manual, and the MPS™ Hazardous Locations User Guide. Abuse, mechanical damage, alterations, or other operations not done in accordance with these documents voids the Nevada Nanotech Systems Standard Limited Warranty.

With respect to firmware, the obligation of Nevada Nanotech Systems under this limited warranty is limited to a firmware upgrade, performed by Nevada Nanotech Systems, when such upgrade is deemed necessary, solely by Nevada Nanotech Systems, to address a critical safety or functional issue. This warranty is limited to the above and expressly excludes firmware upgrades that include enhanced or modified functionality of features.

Nevada Nanotech Systems does not warrant that the electronic or software operation of the Product will be uninterrupted or error-free, or that all such errors may be corrected. In addition to all other limitations, this limited warranty is limited by and does not apply to the following: (1) products or parts that have been altered or modified (e.g., to alter functionality or capability) by anyone other than Nevada Nanotech Systems; (2) damage caused by use with another product; (3) damage caused by accident, abuse, misuse, liquid contact, fire, or other external cause; (4) damage caused by operating the Product outside Nevada Nanotech System product guidelines; (5) Products whose electronic module housings have been opened or otherwise tampered with; and (6) defects caused by normal wear and tear or otherwise due to the normal aging of the Product, unless damage has occurred due to a defect in materials or workmanship.

This limited warranty is expressly in lieu of any and all representations, express or implied, including but not limited to the warranty of fitness for a particular purpose. Nevada Nanotech Systems will not be liable for loss or damage of any kind connected to the use of its products or failure of its products to function or operate properly.

REPAIR OR REPLACEMENT AS PROVIDED UNDER THIS LIMITED WARRANTY IS THE EXCLUSIVE REMEDY OF THE PURCHASER. EXCEPT FOR THE WARRANTIES CONTAINED IN THIS LIMITED WARRANTY, NEVADA NANOTECH SYSTEMS MAKES NO OTHER WARRANTY OF ANY KIND, EXPRESS OR IMPLIED, IN FACT OR BY LAW, WHETHER OF MERCHANTABILITY, FITNESS FOR ANY PARTICULAR PURPOSE OR OTHERWISE. NO ADVICE OR INFORMATION, WHETHER ORAL OR WRITTEN, OBTAINED FROM NEVADA NANOTECH SYSTEMS OR ELSEWHERE, WILL CREATE ANY WARRANTY NOT EXPRESSLY STATED IN THESE TERMS AND CONDITIONS. YOUR SOLE AND EXCLUSIVE REMEDY UNDER THIS LIMITED WARRANTY SHALL BE PRODUCT REPAIR OR REPLACEMENT AS PROVIDED HEREIN. NEVADA NANOTECH SYSTEMS SHALL NOT BE LIABLE FOR INDIRECT, INCIDENTAL, PUNITIVE, OR CONSEQUENTIAL DAMAGES OF ANY NATURE WHATSOEVER. NEVADA NANOTECH SYSTEMS IS NOT RESPONSIBLE FOR ANY LOSS OF PROFITS OR REVENUES. NEVADA NANOTECH SYSTEMS IS NOT RESPONSIBLE FOR ANY DAMAGE TO PROPERTY OR PERSONS CAUSED BY YOUR USE OF THE PRODUCT, INCLUDING YOUR FAILURE TO UNDERSTAND THE FUNCTIONALITIES OF THE PRODUCT OR FAILURE TO DETERMINE THE SUITABILITY OF THE PRODUCT FOR YOUR INTENDED USE. IN NO EVENT WILL OUR LIABILITY EXCEED THE AMOUNT PAID BY YOU FOR THE PRODUCT.

The foregoing limitations will apply even if any warranty or remedy provided under this Agreement fails of its essential purpose. Some jurisdictions do not allow exclusion or limitation of incidental or consequential damages or how long an implied warranty lasts, so the above limitations may not apply to you. This limited warranty gives the Purchaser specific legal rights, and the Purchaser may also have other additional rights, which vary from State to State or by countries.

In the event of any dispute regarding the Product, prior to bringing any civil suit, the Purchaser and Nevada Nanotech Systems agree to resolve any Claims by ARBITRATION that must be brought through a mutually acceptable arbitrator in Reno, Nevada. Such arbitration will be conducted under the Commercial Arbitration Rules (Amended and Effective October 1, 2013) of the American Arbitration Association (available at <http://www.adr.org/commercial>). For the purposes of this section, references to "Purchaser" include the original OEM manufacturer, its officers, directors, employees, customers, beneficiaries, and assigns, and references to "Claim" shall include any dispute, claim or controversy arising from or relating to: (1) the Product, whether based in contract; tort; fraud; misrepresentation; state or federal statute, regulation, ordinance; or any other legal or equitable theory, and (2) this limited warranty. There shall be no right or authority for any Claims to be arbitrated on a class action basis. This Dispute Resolution agreement is part of a transaction involving interstate commerce and is governed by the Federal Arbitration Act, which governs its enforcement and interpretation.

No other person or company is authorized to change this limited warranty, and the Purchasers are solely responsible for any other additional warranties regarding any other products that the Products are incorporated into.

To obtain warranty service for the Product, the Purchaser must contact Nevada Nanotech Systems by calling +1 775 972 8943, emailing customer-support@nevedanano.com, or requesting return at <https://www.nevedanano.com/mps-flammable-gas-sensor-support>. Nevada Nanotech Systems Customer Service will give the warranty guidelines and issue a Return Merchandise Authorization (RMA) number that authorizes return of the material for verification of defects. The Purchaser is responsible for any necessary shipping charges for returned or replaced products and all returns must be clearly marked with the RMA number issued. Nevada Nanotech Systems will decide, at its discretion, to repair or replace any of its Products found to be defective. Any replacement under this limited warranty will only be made with the same or similar product of the same or similar value and will not include cash, credits, or other types of products. All repaired or replacement products will be covered for one year from the date of the original purchase. If Nevada Nanotech Systems determines that the problem with the Product is not covered under this limited warranty, Nevada Nanotech Systems will notify the Purchaser and inform the Purchaser of service or replacement alternatives that are available on a fee basis.

Nevada Nanotech Systems, Inc.
1395 Greg St, Suite 102
Sparks, NV 89431
Phone: +1 775 972 8943



Nevada Nanotech Systems Inc.

1395 Greg Street, Suite 102

Sparks, Nevada 89431

United States

Tel: +1 775 972 8943

Fax: +1 775 972 8078 info@nevedanano.com

www.nevedanano.com

SM-UM-0009-03