



# MOLECULAR PROPERTY SPECTROMETER™ (MPS™)

## A2L REFRIGERANT GAS SENSOR USER MANUAL



Industrial form factor



Residential form factor

NNTS Proprietary Information

SM-UM-0004-07



131 BUSINESS CENTER DR. STE. A3  
ORMOND BEACH, FL 32174  
(386) 872-7668  
WWW.GASLAB.COM | SALES@GASLAB.COM

## Notices

SM-UM-0004-07

Copyright © 2018-2021 Nevada Nanotech Systems Inc. All rights reserved.

1395 Greg Street, Suite 102

Sparks, Nevada 89431

### All Rights Reserved

This publication is protected by copyright and all rights are reserved. No part of it may be reproduced or transmitted by any means or in any form, without prior consent in writing from NevadaNano.

The information in this document has been carefully checked and is believed to be accurate. However, changes are made periodically. These changes are incorporated in the newer publication editions. NevadaNano may improve and/or change products described in this publication at any time. Due to continuing system improvements, NevadaNano is not responsible for inaccurate information which may appear in this manual. For the latest product updates, consult the NevadaNano web site at [www.nevadanano.com](http://www.nevadanano.com). In no event will NevadaNano be liable for direct, indirect, special exemplary, incidental, or consequential damages resulting from any defect or omission in this document, even if advised of the possibility of such damages.

In the interest of continued product development, NevadaNano reserves the right to make improvements in this document and make the products it describes at any time, without notices or obligation.

The Molecule logo is a trademark of Nevada Nanotech Systems Inc. Use of the logos for commercial purposes without the prior written permission of NevadaNano may constitute trademark infringement and unfair competition in violation of federal and state laws.

NevadaNano, the Molecule logo, Molecular Property Spectrometer, and MPS are trademarks of Nevada Nanotech Systems Inc.

Other trademarks and trade names may be used in the document to refer to either the entities claiming the marks and names or their products. Nevada Nanotech Systems Inc. disclaims any proprietary interest in trademarks and trade names other than its own.



Please Recycle

Shipping materials are recyclable. Please save them for later use, or dispose of them appropriately.

## Contents

1. How the MPS A2L Refrigerant Gas Sensor Works .....	3
2. Communicating with the MPS A2L Refrigerant Gas Sensor .....	3
2.1. Serial (UART) Communication .....	3
2.1.1. Data Representation .....	4
2.1.2. Protocol Specification .....	4
2.1.3. Checksum Calculation .....	6
2.1.4. Startup and Measurement Sequence .....	7
2.1.5. Command Table .....	12
2.1.6. Command Descriptions .....	12
2.2. Sensor Analog Output Mode .....	16
3. Testing the MPS A2L Refrigerant Gas Sensor .....	16

3.1. Setup #1: Testing in a Tank.....	17
3.2. Setup #2: Testing in Various Environmental Conditions .....	18
4. Operating Conditions for the MPS A2L Refrigerant Gas Sensor .....	19
4.1. Response to Other Gases .....	19
4.1.1. Carbon Dioxide (CO <sub>2</sub> ).....	19
4.2. Hazardous Locations and System Integration .....	20
5. Electromechanical Integration .....	21
5.1. General Guidelines .....	21
5.2. A2L Mini Critical Dimensions and Pinout .....	22
5.3. IS Critical Dimensions and Pinout.....	23
6. Certificates of Compliance.....	24

## 1. How the MPS A2L Refrigerant Gas Sensor Works

The MPS A2L Refrigerant Gas Sensor is a smart sensor with built-in environmental compensation that detects and accurately quantifies low-global-warming, mildly flammable (A2L) refrigerants used in HVAC applications. It is robust, extremely poison-resistant, and comes factory-calibrated. Sensor readings are output on a standard digital bus or industry-standard analog output.

The MPS transducer is a micro-machined membrane with an embedded Joule heater and resistance thermometer. The MEMS transducer is mounted on a PCB and packaged inside a filtered enclosure that is permeable to ambient air. Presence of a flammable refrigerant gas causes changes in the thermodynamic properties of the air/gas mixture; these properties are measured by the transducer and processed by patent-pending algorithms to report an accurate concentration.

## 2. Communicating with the MPS A2L Refrigerant Gas Sensor

This section describes the software interface requirements for the MPS A2L Refrigerant Gas Sensor and will be useful to system integrators when designing the sensor assembly into a final product.

The preferred method of communicating with the sensor is over the serial interface using the UART (Universal Asynchronous Receiver/Transmitter) protocol. Section 2.1 provides the necessary information for communicating using UART.

### 2.1. Serial (UART) Communication

Communication with the system over the serial interface (UART) will allow an external user or system to execute the commands provided in the Command Table in Section 2.1.5. Users may also refer to the Command Descriptions in Section 2.1.6 for usage descriptions.

Serial connection parameters:

Parameter	Size
Baud Rate	38400
Data Size	8 bits
Parity	None
Stop Bit	1 bit

### 2.1.1. Data Representation

All integer values (16 bits or 32 bits) are represented in Little Endian format (LSB first). This means when an integer is transmitted on the serial interface, the least significant byte (LSB) is transmitted first and the most significant byte (MSB) is transmitted last.

Floating point numbers are represented in IEEE 754 format.

### 2.1.2. Protocol Specification

Communication to and from the MPS A2L Refrigerant Gas Sensor is made up of “packets.” The communication paradigm is that of “request” and “reply.” An external host sends a “request” packet to the sensor. The sensor returns a “reply” packet to the external host. A packet consists of a fixed size “header” and a variable length “payload.” It is possible for a packet to have no payload (length of zero) where a packet contains only a header. The payload, if any, typically consists of “parameters” for a request or “result” for a reply. Even when a reply does not contain any result, a reply is still sent with the header as an acknowledgement of the request.

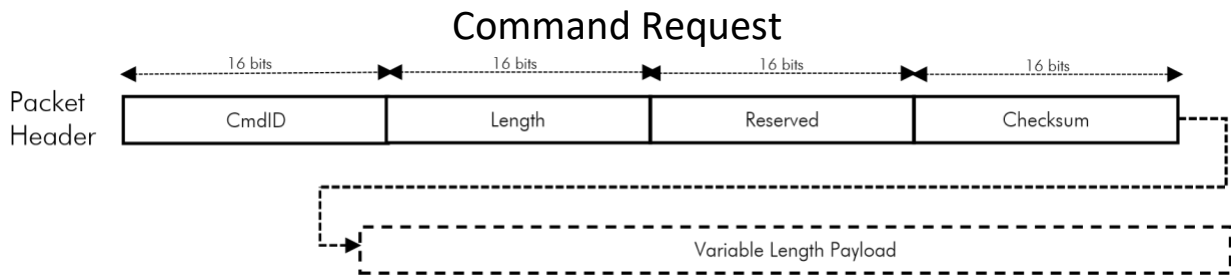

Figure 1: Request Packet Structure

The Request Packet (Figure 1) consists of the following fields:

Field	Size	Description
CmdID	2 Bytes	Command ID of this request (see Command Table in section 2.1.5). Although CmdID uses only 1 byte, it is extended to 2 bytes in the Request Header for alignment purposes.
Length	2 Bytes	Length of the Payload (0 if no payload)
Reserved	2 Bytes	Reserved for future use (zero filled)

Checksum	2 Bytes	Checksum of the entire packet
Variable Length Payload	variable	Command parameters for this request

## Command Reply

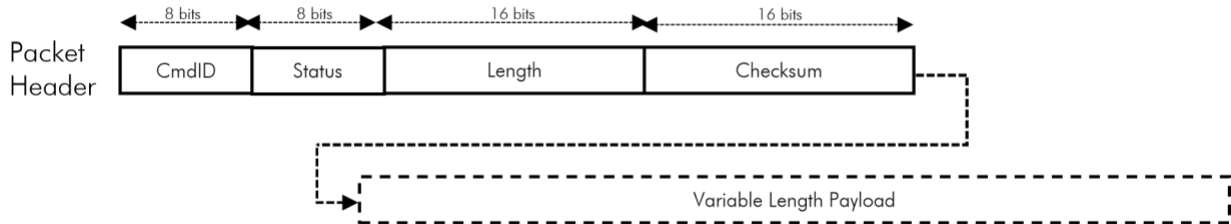

Figure 2: Reply Packet Structure

The Reply Packet (Figure 2) consists of the following fields:

Field	Size	Description
CmdID	1 Byte	Command ID (should match the original request)
Status	1 Byte	Return status of the request
Length	2 Bytes	Length of the Payload (0 if no payload)
Checksum	2 Bytes	Checksum of the entire packet
Variable Length Payload	variable	Command parameters for this request

The Status field consists of the following possible return values:

Fault	Fault Message	Explanation	%LEL Output	User action
0x00	OK	MPS is operating normally and has no errors	Normal	None
0x01	CRC_FAILED	Transmitted data failed checksum	N/A	Verify checksum calculation is correct. See Section 2.1.3.
0x02	BAD_PARAM	Illegal or bad parameters specified	N/A	Verify parameter given in command is correct.
0x03	EXE_FAILED	Execution of command failed	N/A	Contact support.
0x04	NO_MEM	Insufficient memory for operation	N/A	Contact support.
0x05	UNKNOWN_CMD	Unknown Command ID specified	N/A	Verify Command ID is correct. See Section 2.1.5.
0x07	INCOMPLETE_COMMAND	Incomplete or truncated command	N/A	Verify entire packet header and payload (if any) is fully sent.
0x20	HW_ERR_AO	Analog out malfunction (only if AO functionality enabled)	-100 %LEL	Contact support.

0x22	HW_ERR_VREF	Voltage out of range	-100 %LEL	Supply 3.3-5.0 ±5% VDC. If this error persists for more than 5 cycles, this error will latch until the sensor is power cycled and supplied correct voltage
0x24	HW_ENV_SNSR_MALFUNCTION	Environmental sensor malfunction	-100 %LEL	Occurrence of this error will latch the sensor in this condition and no longer allow normal operation. Contact support.
0x25	HW_ERR_MCU_FLASH	Microcontroller error	-100 %LEL	Contact support.
0x26	HW_SENSOR_INITIALIZATION	Sensor in initialization mode (10 cycles)	-100 %LEL	Wait 10 cycles (~20 sec) for sensor to initialize.
0x32	HW_SENSOR_MALFUNCTION	Gas sensing element malfunction	-100 %LEL	Contact support.

### 2.1.3. Checksum Calculation

The algorithm for checksum calculation is that of 16-bit CRC CCITT with start byte 0xFFFF. Checksum is computed over the entire packet (header and payload). The checksum field in the header is initialized with zeros before computing checksum. If there is no payload, checksum is computed against the header only. The following sample C code can be used to calculate the checksum for a buffer of a given size:

```
#include <stdlib.h>
#include <stdint.h>

static uint16_t crc_table[256] = {
    0x0000, 0x1021, 0x2042, 0x3063, 0x4084, 0x50a5, 0x60c6, 0x70e7,
    0x8108, 0x9129, 0xa14a, 0xb16b, 0xc18c, 0xd1ad, 0xe1ce, 0xf1ef,
    0x1231, 0x0210, 0x3273, 0x2252, 0x52b5, 0x4294, 0x72f7, 0x62d6,
    0x9339, 0x8318, 0xb37b, 0xa35a, 0xd3bd, 0xc39c, 0xf3ff, 0xe3de,
    0x2462, 0x3443, 0x0420, 0x1401, 0x64e6, 0x74c7, 0x44a4, 0x5485,
    0xa56a, 0xb54b, 0x8528, 0x9509, 0xe5ee, 0xf5cf, 0xc5ac, 0xd58d,
    0x3653, 0x2672, 0x1611, 0x0630, 0x76d7, 0x66f6, 0x5695, 0x46b4,
    0xb75b, 0xa77a, 0x9719, 0x8738, 0xf7df, 0xe7fe, 0xd79d, 0xc7bc,
    0x48c4, 0x58e5, 0x6886, 0x78a7, 0x0840, 0x1861, 0x2802, 0x3823,
    0xc9cc, 0xd9ed, 0xe98e, 0xf9af, 0x8948, 0x9969, 0xa90a, 0xb92b,
    0x5af5, 0x4ad4, 0x7ab7, 0x6a96, 0x1a71, 0x0a50, 0x3a33, 0x2a12,
    0xdbfd, 0xcbdc, 0xfbbf, 0xeb9e, 0x9b79, 0x8b58, 0xbb3b, 0xab1a,
    0x6ca6, 0x7c87, 0x4ce4, 0x5cc5, 0x2c22, 0x3c03, 0x0c60, 0x1c41,
    0xedae, 0xfd8f, 0xcdec, 0xddcd, 0xad2a, 0xbd0b, 0x8d68, 0x9d49,
    0x7e97, 0x6eb6, 0x5ed5, 0x4ef4, 0x3e13, 0x2e32, 0x1e51, 0x0e70,
    0xff9f, 0xefbe, 0xdfdd, 0xcffc, 0xbf1b, 0xaf3a, 0x9f59, 0x8f78,
    0x9188, 0x81a9, 0xb1ca, 0xa1eb, 0xd10c, 0xc12d, 0xf14e, 0xe16f,
    0x1080, 0x00a1, 0x30c2, 0x20e3, 0x5004, 0x4025, 0x7046, 0x6067,
    0x83b9, 0x9398, 0xa3fb, 0xb3da, 0xc33d, 0xd31c, 0xe37f, 0xf35e,
    0x02b1, 0x1290, 0x22f3, 0x32d2, 0x4235, 0x5214, 0x6277, 0x7256,
    0xb5ea, 0xa5cb, 0x95a8, 0x8589, 0xf56e, 0xe54f, 0xd52c, 0xc50d,
```

```

0x34e2, 0x24c3, 0x14a0, 0x0481, 0x7466, 0x6447, 0x5424, 0x4405,
0xa7db, 0xb7fa, 0x8799, 0x97b8, 0xe75f, 0xf77e, 0xc71d, 0xd73c,
0x26d3, 0x36f2, 0x0691, 0x16b0, 0x6657, 0x7676, 0x4615, 0x5634,
0xd94c, 0xc96d, 0xf90e, 0xe92f, 0x99c8, 0x89e9, 0xb98a, 0xa9ab,
0x5844, 0x4865, 0x7806, 0x6827, 0x18c0, 0x08e1, 0x3882, 0x28a3,
0xcb7d, 0xdb5c, 0xeb3f, 0xfb1e, 0x8bf9, 0x9bd8, 0xabbb, 0xbb9a,
0x4a75, 0x5a54, 0x6a37, 0x7a16, 0x0af1, 0x1ad0, 0x2ab3, 0x3a92,
0xfd2e, 0xed0f, 0xdd6c, 0xcd4d, 0xbdaa, 0xad8b, 0x9de8, 0x8dc9,
0x7c26, 0x6c07, 0x5c64, 0x4c45, 0x3ca2, 0x2c83, 0x1ce0, 0x0cc1,
0xef1f, 0xff3e, 0xcf5d, 0xdf7c, 0xaf9b, 0xbfba, 0x8fd9, 0x9ff8,
0x6e17, 0x7e36, 0x4e55, 0x5e74, 0x2e93, 0x3eb2, 0x0ed1, 0x1ef0,
};
uint16_t crc_generate(uint8_t *buffer, size_t length, uint16_t startValue)
{
    uint16_t
    crc;    uint8_t
    *p;    int ii;
    crc = startValue;

    for(p = buffer, ii = 0; ii < length; ii++) {

        crc = (crc << 8) ^ crc_table[(crc >> 8) ^ *p];
    p++;    }    return crc;
}

```

For more information on how to use the above function, please look at the sample test program “Sample Code” located here: <https://nevadanano.com/downloads>

#### 2.1.4. Startup and Measurement Sequence

Figure 3 describes the recommended steps after powering on the sensor plus the measurement sequence for getting answer data. The major steps consist of the following:

- After powering on the sensor, wait for the sensor to boot up completely (~3 seconds).
- Verify communication channel by asking the sensor for version information.
  - Firmware version information can be used to determine if a new firmware is available for upgrade.
  - Protocol version can be used to determine available commands, answers or new data.
- Start measurement in “continuous” mode.
- Wait 2 seconds for the first measurement to complete.
- Get Answer.
- Repeat process to get answer at desired frequency.

The sensor initializes for the first 10 cycles after powering up. During this period, the sensor output is set to “-100 %LEL”, the sensor status is set to HW\_SENSOR\_INITIALIZATION, and the sensor is not capable of reporting gas concentrations. Once initialization is complete, the sensor is ready to report gas concentrations, and the status is set to 0x00.

*Note: It takes approximately 2 seconds to calculate and complete a measurement. If multiple requests to read the Answer register (0x01) were made within a two-second window, one might get the same answer. This depends on whether a new measurement is calculated between multiple Answer requests. The MPS Cycle Count ("COUNT") in the Answer Response is incremented after each measurement is calculated. Therefore, when processing an "answer," one should compare the COUNT value in the answer against the COUNT value from the previous answer. If the COUNT value did not increment, this is a repeated answer. If the COUNT value incremented, this is a new answer from the latest measurement cycle. When continuous measurement is stopped and restarted, the COUNT value resets to 1 with the first measurement.*



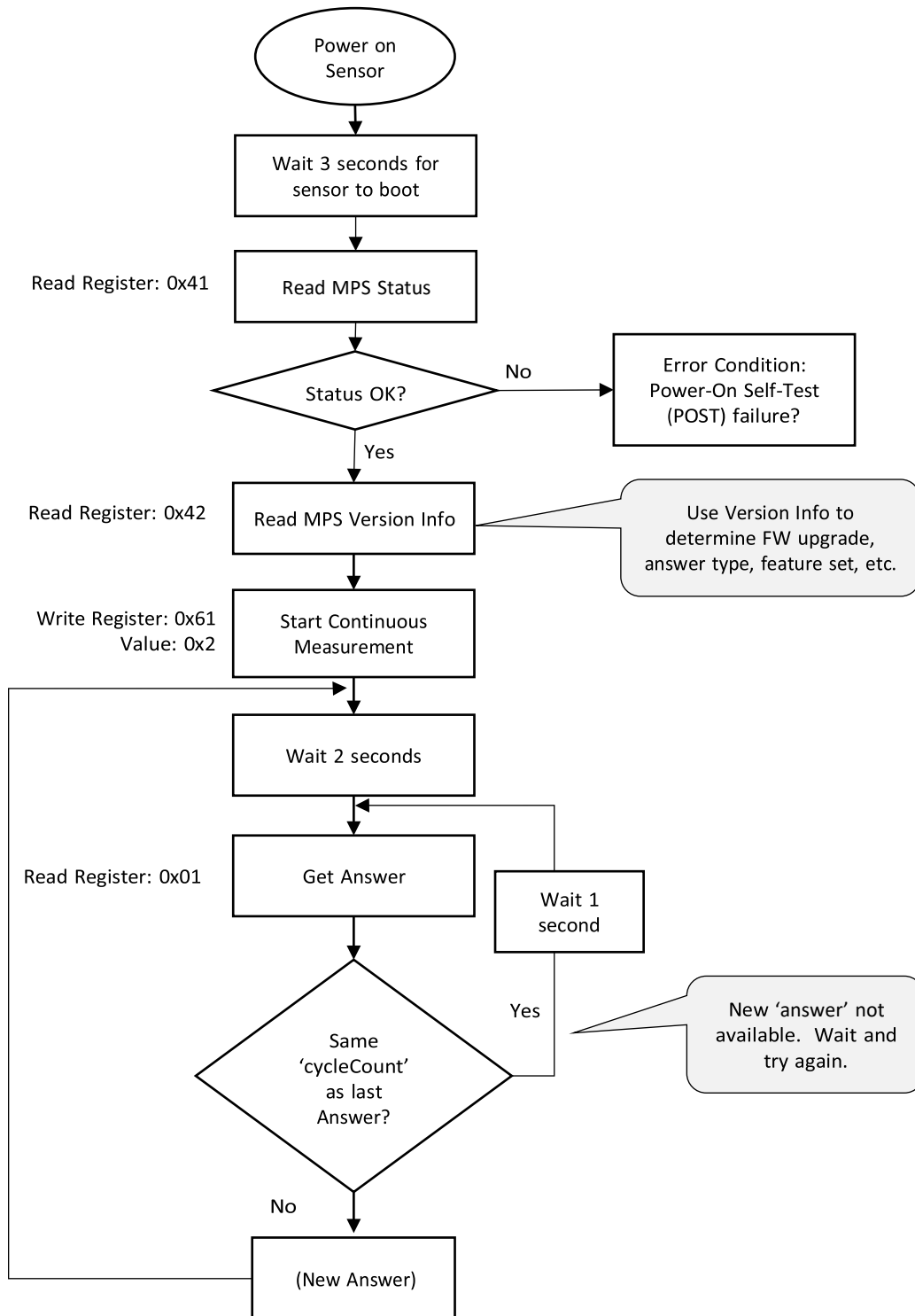
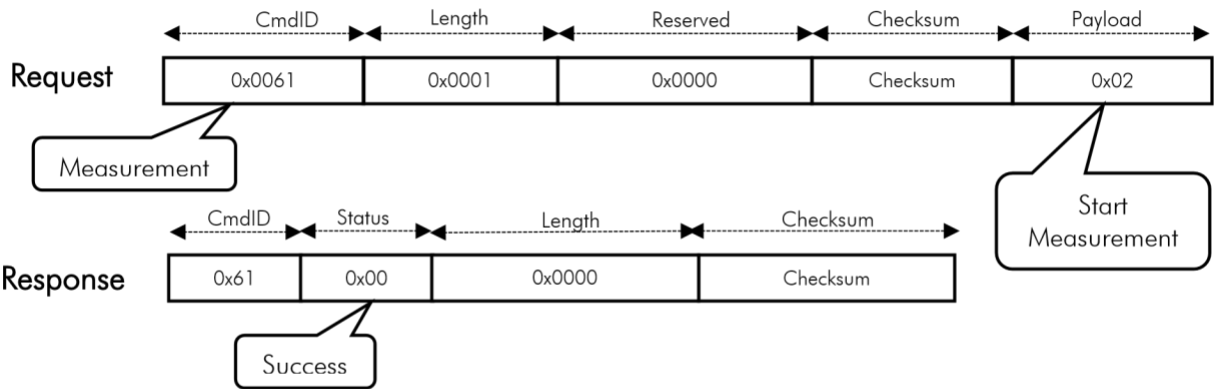

Figure 3: Startup and Measurement Sequence



Figure 4 describes sample Request and Response packets for the Perform Measurement and GetAnswer Vector sequences.

## Perform Measurement



## Get Answer Vector

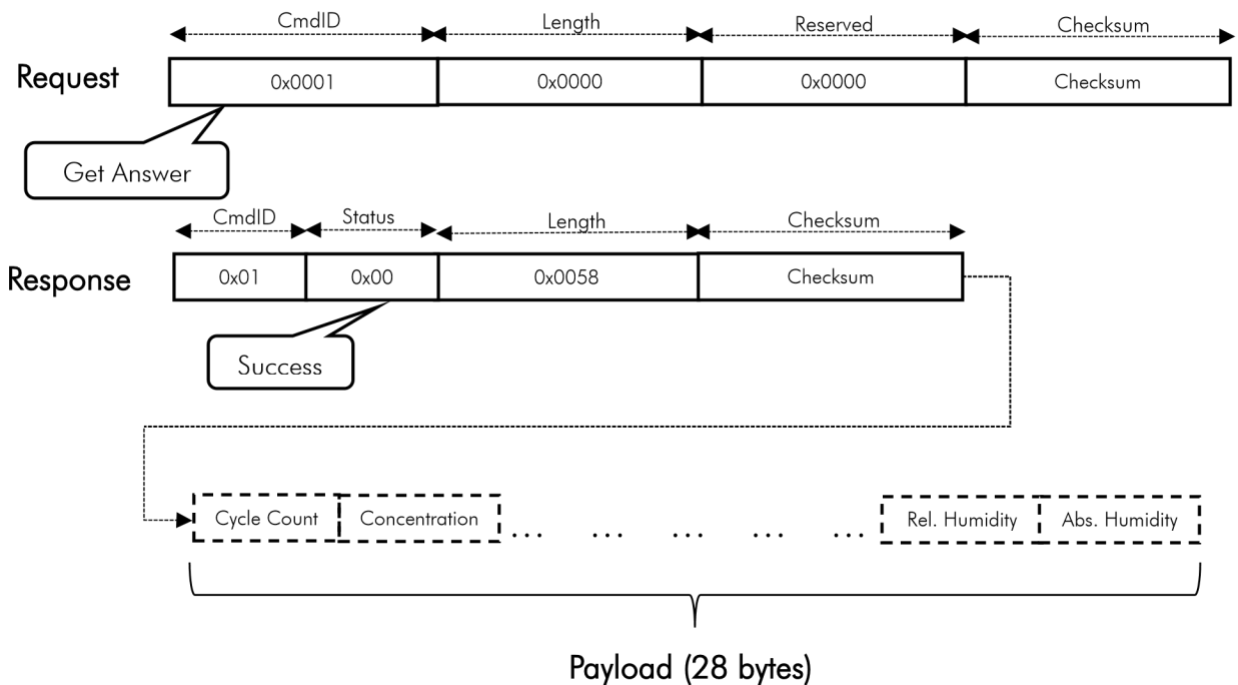

Figure 4: Sample Request and Response Packets for Performing Measurement and Get Answer Vector

## 2.1.5. Command Table

Hex Code	Command ID	Payload Length [bytes]	
		Request	Response
0x01	ANSWER	0	28
0x03	CONC	0	4
0x04	ID	0	4
0x09	ENG_DATA	0	84-128
0x21	TEMP	0	4
0x22	PRES	0	4
0x23	REL_HUM	0	4
0x24	ABS_HUM	0	4
0x41	STATUS	0	1
0x42	VERSION	0	8
0x43	SENSOR_INFO	0	68
0x61	MEAS	1	0
0x62	SHUT_DOWN	0	0

## 2.1.6. Command Descriptions

### 1. Command 0x01 – ANSWER – Read Complete Answer

Description: Returns a complete answer in one read operation.

Parameters: N/A

Response: CYCLE\_COUNT 32-bit unsigned value. Cycle Number of this measurement (incremented after each measurement)

CONC	32-bit floating point value. Flammable gas concentration [%LEL]
ID	32-bit unsigned value. Flammable gas ID. See “Command 0x04 – ID” for descriptions of gas ID values.
TEMP	32-bit floating point value. Ambient temperature [°C]
PRESSURE	32-bit floating point value. Ambient pressure [kPa]
REL_HUM	32-bit floating point value. Ambient relative humidity [%RH]
ABS_HUM	32-bit floating point value. Ambient absolute humidity [ $\frac{g}{m^3}$ ]

*m*

### 2. Command 0x03 – CONC – Read Flammable Gas Concentration

Description: Returns flammable gas concentration (%LEL) as measured by the MPS.

Parameters: N/A

Response: CONC 32-bit floating point value. Flammable gas concentration (%LEL)

### 3. Command 0x04 – ID – Read Flammable Gas ID

Description: Returns flammable gas ID as determined by the MPS.

Parameters: N/A

Response: ID 32-bit unsigned value. Flammable gas ID.

ID	Description
0	No Gas
7	Refrigerant
253	Unknown Gas
254	Under Range – Concentration less than 0 %LEL
255	Over Range – Concentration greater than 100 %LEL

### 4. Command 0x09 – ENG\_DATA – Read Engineering Data

Description: Returns raw engineering (binary) data for analysis and debugging. Parameters: N/A

Response: LENGTH 32-bit unsigned value. Length of engineering data.  
 DATA Engineering data (80 to 124 bytes). Actual size of data is specified in the LENGTH field.

### 5. Command 0x21 – TEMP – Read Temperature

Description: Returns the ambient temperature (°C) as reported by the integrated environmental sensor.

Parameters: N/A

Response: TEMP; 32-bit floating point value. Ambient temperature (°C).

### 6. Command 0x22 – PRES – Read Pressure

Description: Returns the ambient pressure (kPa) as reported by the integrated environmental sensor.

Parameters: N/A

Response: PRESSURE; 32-bit floating point value. Ambient pressure (kPa).

### 7. Command 0x23 – REL\_HUM – Read Relative Humidity

Description: Returns the ambient relative humidity (%RH) as reported by the integrated environmental sensor.

Parameters: N/A

Response: REL\_HUM 32-bit floating point value. Ambient relative humidity (%RH).

### 8. Command 0x24 – ABS\_HUM – Read Absolute Humidity

Description: Returns the ambient absolute humidity ( $\frac{g}{m^3}$ ) as calculated by the MPS.

Parameters: N/A

Response: ABS\_HUM 32-bit floating point value. Ambient absolute humidity ( $\frac{g}{m^3}$ ).

### 9. Command 0x41 – STATUS – Read MPS Status

Description: Returns the status of the MPS; refer to Sec. 2.1.2 for status descriptions.

Parameters: N/A

Response: STATUS 8-bit unsigned value. Status of MPS

### 10. Command 0x42 – VERSION – Read MPS Version Info

Description: Returns the software, hardware and protocol versions of the MPS.

Parameters: N/A

Response: SW\_VERSION 8-bit unsigned values. Version is W.X.Y.Z  
 HW\_VERSION 8-bit unsigned values. Version is W.X  
 PROTOCOL\_VERSION 8-bit unsigned values. Version is W.X

MPS Version Info																															
1	2	3	4	5	6	7	8	9	10	11	12	13	14	15	16	17	18	19	20	21	22	23	24	25	26	27	28	29	30	31	32
SW Version W [7:0]								SW Version X [7:0]								SW Version Y [7:0]								SW Version Z [7:0]							
33	34	35	36	37	38	39	40	41	42	43	44	45	46	47	48	49	50	51	52	53	54	55	56	57	58	59	60	61	62	63	64
HW Version W [7:0]								HW Version X [7:0]								Protocol Version W [7:0]								Protocol Version X [7:0]							

### 11. Command 0x43 – SENSOR\_INFO – Read MPS Sensor Info

Description: Returns information about the sensor.

Parameters: N/A

Response: SERIAL\_NUM Sensor serial number. 32 bytes, zero-padded ASCII string.  
 SENSOR\_TYPE Sensor type. 32-bit unsigned integer. (Note: “MPS A2L Refrigerant Gas Sensor” sensor type = 0x04)  
 CAL\_DATE Date of last calibration. 16 bytes, zero-padded ASCII string. Format is MM/DD/YYYY.  
 MFG\_DATE Date of manufacture. 16 bytes, zero-padded ASCII string. Format is MM/DD/YYYY.

## 12. Command 0x61 – MEAS – Perform Measurement

**Description:** Sets the sensing mode (idle, single, or continuous) and “concentration unit” in the measurement.

**Parameters:** The parameter to the Measurement command is 1 byte in length but consists of two, 4-bit values: Concentration Unit (bits 7:4) and Mode (bits 3:0).

Measurement Value (Byte)	
Conc. Unit [7:4]	Mode [3:0]

The “concentration unit” (bits 7:4 of the measurement byte) is %LEL; this is the unit that will be reported for commands 0x01 and 0x03.

Unit	Name	Description
0x0	PERCENT_LEL	Concentration reported as %LEL.

The measurement mode (bits 3:0 of the measurement byte) consists of the following possible values:

MODE	Name	Description
0x2	MPS_CONT	MPS operates in an autonomous, continuous mode
0x3	MPS_STOP	Stop measurement – no measurements are being taken

Response: N/A

## 13. Command 0x62 – SHUT\_DOWN – Shut down MPS

**Description:** Prepares the MPS for a shutdown by saving necessary data and states.

**Parameters:** N/A

**Response:** N/A

## 2.2. Sensor Analog Output Mode

The MPS A2L Refrigerant Gas Sensor is factory-configurable to report gas concentrations via an analog signal that mimics the output of conventional catalytic bead flammable gas sensors. By default, this feature is disabled. The analog output signal from the MPS A2L Refrigerant Gas Sensor is generated with a digital-to-analog converter. The standard analog output range, shown in Fig. 5, is 0.4 V (0 %LEL) to 2.0 V (100 %LEL), linearly increasing at 0.016 V/%LEL. As with the digital

output concentration resolution is 0.1 %LEL for analog outputs. Upon startup, the analog output pin may report between 0.75-1.75 V momentarily (<100 ms) during initialization.

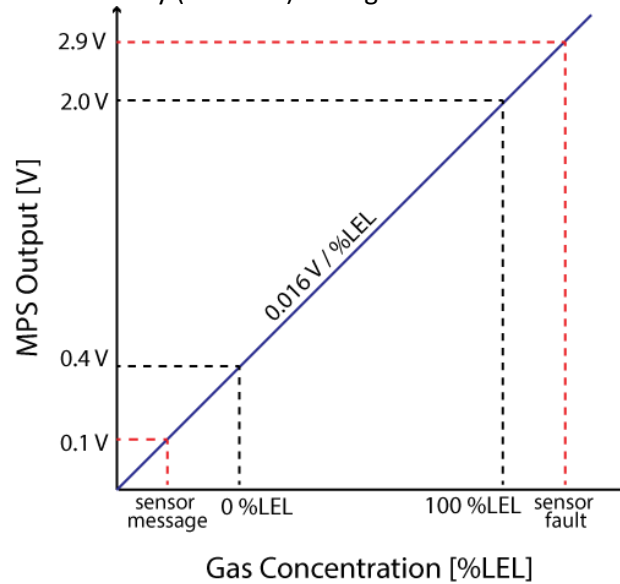

Figure 5: MPS A2L Refrigerant Gas Sensor output when configured in analog mode

When there is an error condition or special status, as reported by the sensor status field (outlined in Section 2.1.2.), the voltage level does not indicate gas concentration. Instead, the voltage is set to report an error or special status (see table below). Only critical statuses and messages that indicate the sensor’s initialization sequence are conveyed to the user. The following table indicates the output voltage corresponding to each sensor message and critical status.

Status	Voltage [V]
HW_ERR_AO	2.9
HW_ERR_VREF	2.9
HW_ENV_SNSR_MALFUNCTION	2.9
HW_ERR_MCU_FLASH	2.9
HW_SENSOR_INITIALIZATION	0.1
HW_SENSOR_MALFUNCTION	2.9

## 3. Testing the MPS A2L Refrigerant Gas Sensor

The MPS A2L Refrigerant Gas Sensor measures molecular properties to determine the quantity of flammable refrigerant gas present in a sample, and automatically compensates out the effects of



humidity, temperature and pressure. The best test setups are those which properly simulate real-world sensor operation. Two such setups are discussed here.

### 3.1. Setup #1: Testing in a Tank

The test setup shown in Figure 6 requires minimal equipment. A single gas cylinder of refrigerant gas is plumbed through a regulator, then a rotameter with a hand-turn valve (or an automated mass flow controller) for modulating flow rate. Humidity-permeable tubing (e.g. Nafion™ TT-110<sup>1</sup>) can be used in-line to humidify the gas stream to the ambient humidity level. The gas is then plumbed into an enclosed volume such as a glass or plastic tank (or the plenum of an HVAC system) containing the sensors. A small fan can be included inside the tank to ensure rapid mixing. A typical test entails operating the sensors in the ambient air inside the control volume, then routing refrigerant gas into the test volume just like a flammable refrigerant gas leak.

As an example, a tank measuring 12 x 12 x 18 inches has a volume of 2,592 in<sup>3</sup> (0.0425 m<sup>3</sup>). R-32 refrigerant reaches 100 %LEL at a concentration of 14.4% by volume in air. So, flowing pure R-32 refrigerant through the rotameter at 300 ml/min (18.3 in<sup>3</sup>/min) for 10.2 minutes will gradually raise the total volume of R-32 in the tank to 186 in<sup>3</sup>, which is 50 %LEL.

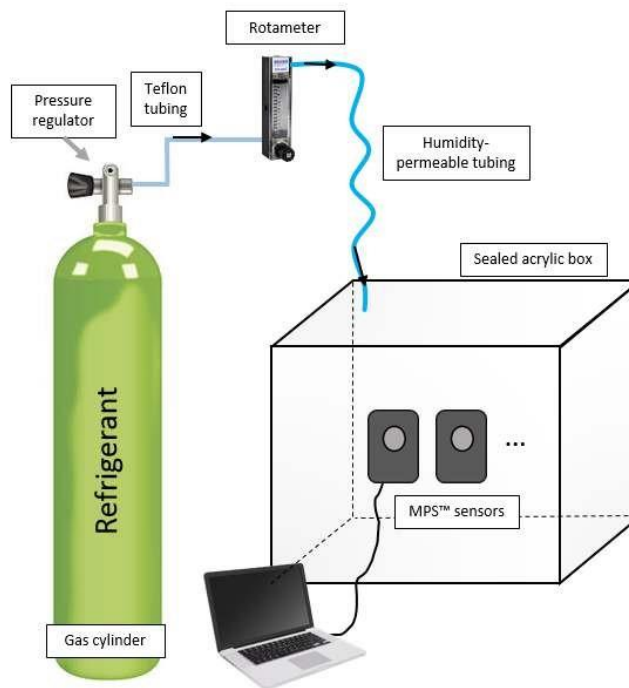

Figure 6: Setup #1--Testing in a Tank

<sup>1</sup> <https://www.permapure.com/products/nafion-tubing/nafion-dryer-performance-and-selectivity/>

### 3.2. Setup #2: Testing in Various Environmental Conditions

A test of sensor response in various environmental conditions can be conducted using the setup shown in Figure 7. Two regulated gas cylinders are used: one containing refrigerant, and the other containing compressed air.

*Important note: Do not use so-called “zero-air,” which is a mix of only two gases—20.9% oxygen, with balance nitrogen—and therefore does not represent the air in which the sensor actually operates (inside an air conditioner, e.g.). Compressed real air contains not only oxygen and nitrogen, but argon, carbon dioxide and other gases. Because the MPS analyzes the molecular properties of the entire air sample and is calibrated using real air, the use of zero-air will compromise the accuracy of its measurements.*

Regulated gas cylinders are connected to a gas mixing system (e.g. Environics 4040) to control gas flow rates and concentrations. The gas travels through a heat exchanger and humidity-permeable tubing (e.g. Nafion™ TT-110), allowing the gas to reach the chamber temperature and relative humidity. Gas then flows serially through each of the MPS sensors and out a vent exhaust-tube. The environmental chamber is programmed with the required temperature/humidity profiles for each test.

Gas profiles are created in the gas mixing system software to deliver the analyte at the correct time.

Flow rate is constant at 300 mL/min for both analyte and air throughout the tests.

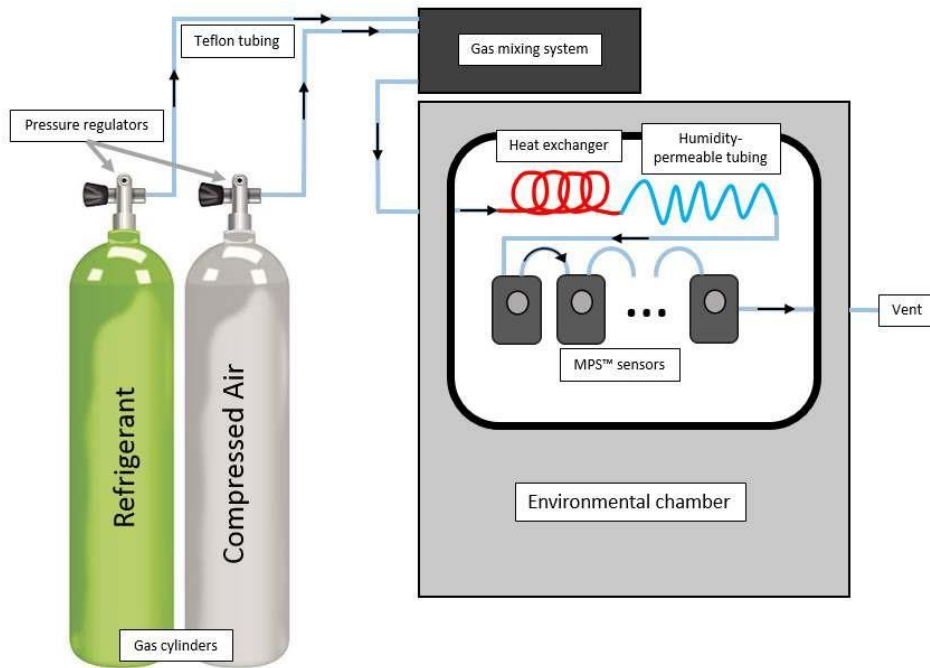

Figure 7: Setup #2: Testing in Various Environmental Conditions

## 4. Operating Conditions for the MPS A2L Refrigerant Gas Sensor

The table below provides a summary of standardized tests and test conditions to which the MPS A2L IS “Industrial” form factor Refrigerant Gas Sensor has been subjected; similar performance can be expected for the Mini “Residential” form factor. The IS sensor has passed all of these tests by demonstrating normal flammable gas detection performance both before and after each test.

Test	Specification	Summary of Test Conditions
High Temperature Operating	IEC 60068-2-2	1000 Hours @ 85°C
Low Temperature Operating	IEC 60068-2-1	1000 Hours @ -50°C
Drop	IEC 60068-2-31	1-meter drop onto concrete
Shock	IEC 60068-2-27	50G peak/11ms half sine pulse, 3-axes (positive and negative pulses)
Vibration	IEC 60068-2-6	31Hz – 150 Hz (2G acceleration), 1 hour per axis, 3-axes
Sand/Dust	MIL-STD-810G Method 510.5	Sand: 150-600 µm SiO <sub>2</sub> particle size, 23 m/s nom. velocity, 5 hours @ 70°C per axis, 3-axes Dust: Red China Clay, 1.5 m/s nom. velocity, 6 hours @ 70°C per axis, 3-axes
Poisoning	NevadaNano	1200 ppm-hours H <sub>2</sub> S (50 ppm for 24 hours) 100 ppm-hours HMDSO (10 ppm for 10 hours) 0.25 ppm-hours NO <sub>2</sub> (3 ppm for 5 minutes) 0.83 ppm-hours HCN (10 ppm for 5 minutes) 0.75 ppm-hours SO <sub>2</sub> (9 ppm for 5 minutes) 0.17 ppm-hours Cl <sub>2</sub> (2 ppm for 5 minutes) 4.17 ppm-hours NH <sub>3</sub> (50 ppm for 5 minutes)
EMC: Radiated Immunity	IEC/EN 61000-4-3	80 MHz – 2.7 GHz up to 10 V/m
EMC: Magnetic Immunity	IEC/EN 61000-4-8	30 A/m, 3-axes
EMC: Electrostatic Discharge	IEC/EN 61000-4-2	Up to 4kV on ground plane; up to 8kV corona discharge

### 4.1. Response to Other Gases

#### 4.1.1. Carbon Dioxide (CO<sub>2</sub>)

Carbon dioxide is a component of normal air at concentrations near 400 ppm. This ambient amount of CO<sub>2</sub> is already taken into account by sensor calibrations. The MPS is unaffected by elevated CO<sub>2</sub> concentrations up to approximately 1% by volume (10,000 ppm); concentrations above this can be misinterpreted by the sensor as refrigerant gas. The sensor is immune to poisoning by CO<sub>2</sub>.

Note: Exhaled human breath contains CO<sub>2</sub> at concentrations of approximately 40,000 ppm. During respiration, the CO<sub>2</sub> replaces oxygen, reducing its concentration from 20.95% by volume in normal air to 13.6-16% in exhaled air. As such, breathing directly onto the sensor can cause it to falsely report refrigerant gas for a brief period.

## 4.2. Hazardous Locations and System Integration

Integrating the MPS into intrinsically safe systems requires additional design consideration. Refer to the MPS Hazardous Locations User Guide (<https://nevedanano.com/downloads>) for information regarding certifications, protection concepts, entity parameters, etc. Note: The MPS A2L Refrigerant Gas Sensor is only hazloc certified in the IS form factor. As such, the Mini form factor is not intended for applications requiring intrinsic safety.

## 5. Electromechanical Integration

### 5.1. General Guidelines

The A2L Mini interconnect system is intended for evaluation purposes. The male header is Samtec P/N: TLW-105-06-G-S and the female connector is Samtec P/N: SLW-105-06-G-S. Both interconnects are readily available in distribution.

The IS pinout is indicated in Figure 11. The mating receptacles are available in distribution, and can be found using Mill-Max P/N: 0384-0-67-80-23-27-10-0.

Note: the Analog Out pin, if unused, must be left unterminated as an "open" or "no-connect" in the system integrator's PCB design.

In powering the MPS sensor, the following criteria need to be met:

- Voltage range must be  $3.3\text{-}5.0\text{ V} \pm 5\%$
- Ripple and noise should not exceed 50 mV
- The supply must be capable of providing at least 35 mA without appreciable voltage drop
- The voltage rise rate at power up should be greater than  $250\ \mu\text{s}$  per volt from a cold start (that is, when powering up a sensor that has been off for more than 5 seconds)
- **Do not solder to the sensor pins**

Achieving the proper voltage rise rate can be accomplished using voltage regulators with "soft-start" capability, though added capacitance (less preferred), or by placing a series resistor between the voltage source and the MPS power pin.

If the voltage rise rate condition above is not met when powering up a sensor that has been off for more than 5 seconds, a small percentage of sensors may power up into a state in which they do not respond to commands or do not generate the proper analog output. If this occurs, shutting power off to the sensor for between 0.5 to 2 seconds and then immediately powering the sensor back on will cause the sensor to recover and power up normally, *even if the voltage rise rate condition above is not met.*

## 5.2. A2L Mini Critical Dimensions and Pinout

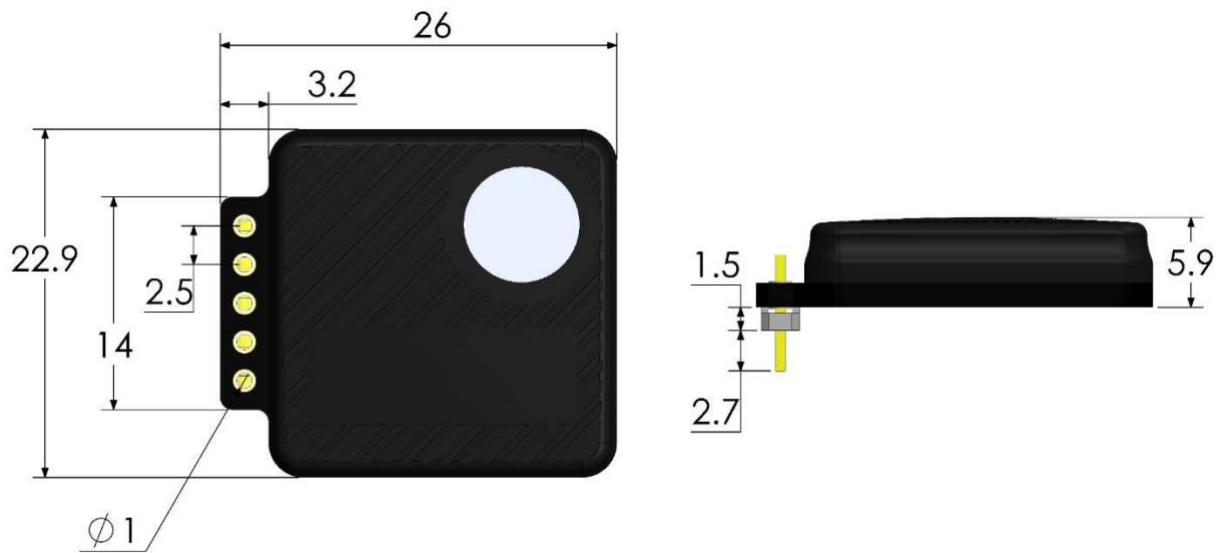

Figure 8: A2L Mini critical dimensions (mm)

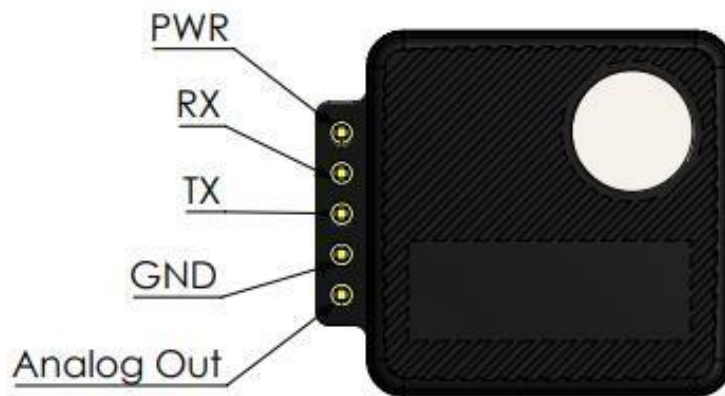

Figure 9: A2L Mini electrical pinout configuration

### 5.3. IS Critical Dimensions and Pinout

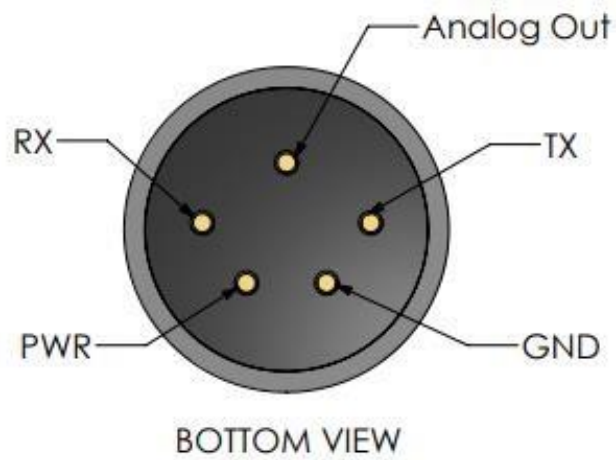
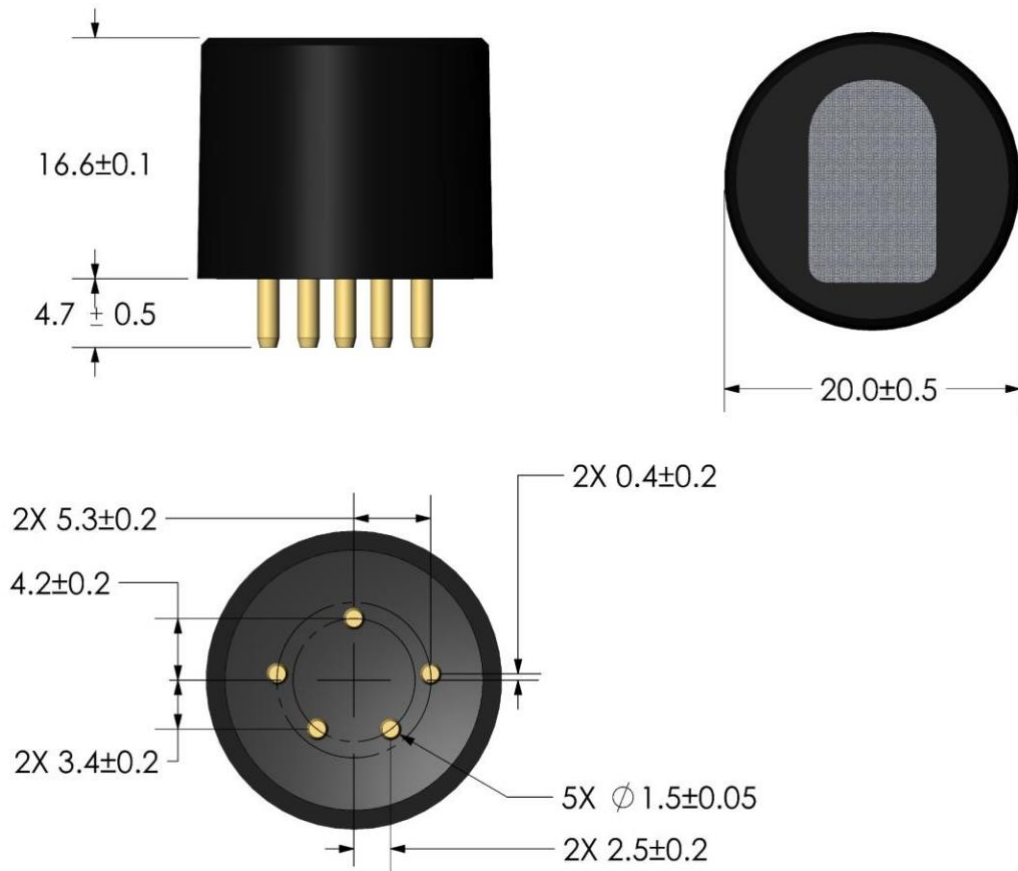

Figure 11: A2L IS electrical pin configuration

## 6. Certificates of Compliance

The following certificates of compliance are available here: <https://nevadanano.com/downloads>

Certificates of Compliance	Certification Body	Certificate Number	MPS Form Factor Certified
Certificate of Conformity (USA)	FM Approvals LLC	FM19US0145U	"IS" Industrial Only
Certificate of Conformity (Canada)	FM Approvals LLC	FM19CA0077U	"IS" Industrial Only
ATEX Certificate	FM Approvals LLC	FM19ATEX0184U	"IS" Industrial Only
IECEX Test Report	FM Approvals LLC	IECEX FMG 19.0028U	"IS" Industrial Only
IECEX Quality Assessment Report	FM Approvals LLC	GB/FME/QAR19.0020/00	"IS" Industrial Only
ATEX Quality Assurance Notification	FM Approvals LLC	FM19ATEXQ0200	"IS" Industrial Only
Certificate of Registration of Quality Management System (ISO 9001:2015)	National Standards Authority of Ireland (NSAI)	19.8213	"IS" Industrial & "Mini" Residential

23

SM-UM-0004-07