



perfect in sensors.

posichron[®]

Magnetostrictive Position Sensors

Installation and operation manual

EN

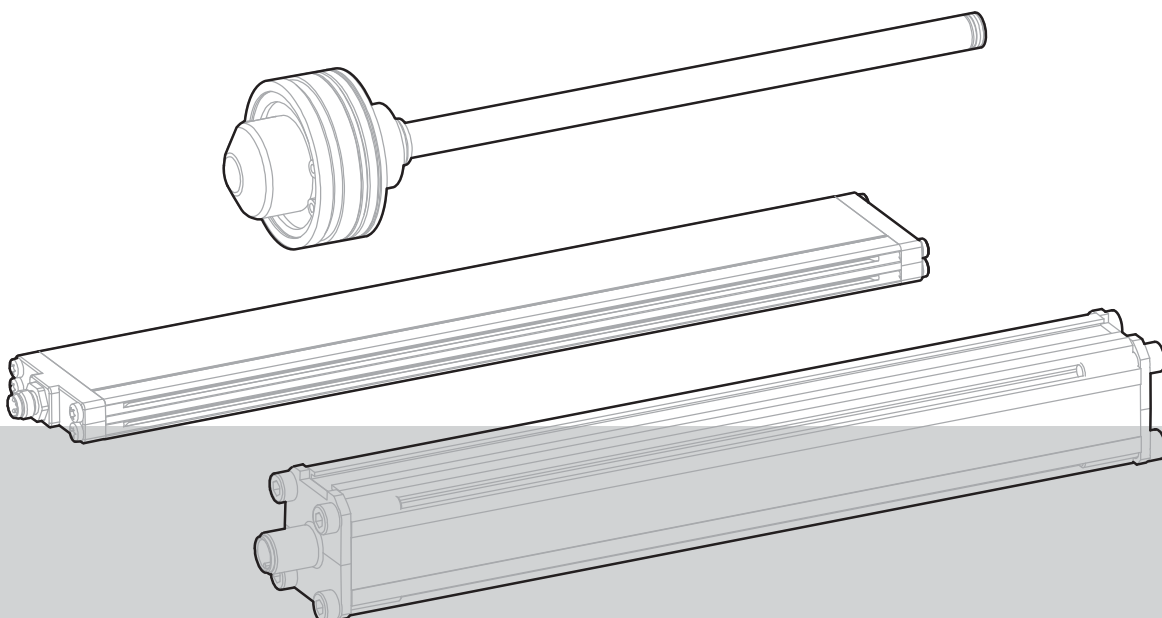

Please read carefully before installation and operation!

© ASM Automation Sensorik Messtechnik GmbH, 2020
All rights reserved.

Am Bleichbach 18 - 24
85452 Moosinning
Germany

Contents	Safety instructions.....	3
	Description.....	6
	Remarks on environmental materials.....	7
	Handling of the position magnets.....	7
	Mounting	
	PCQAxx.....	8
	PCFPxx.....	9
	PCRPxx.....	12
	PCSTxx.....	13
	PCST26.....	18
	Electromagnetic Compatibility (EMC).....	20
	Repair and disposal.....	20
	Specification of the outputs	
	Analog outputs.....	21
	U1, U2, U3, U8 voltage outputs.....	21
	I1, I2 current output	21
	Analog outputs / Signal wiring.....	22
	Analog outputs / Version PMU.....	23
	SSI Serial interface.....	24
	CANOP CANopen interface.....	25
	CAN-SAE J1939 interface.....	38
	Accessories	
	Connector cables.....	42
	Magnets for PCQA/PCFP/PCRP.....	45
	Magnets for PCST.....	49
	Appendix	
	Reliability characteristics.....	55

**Safety
instructions**

Do not use posichron® position sensors in safety critical applications where malfunction or total failure of the sensor may cause danger for man or machine.

For safety related applications additional mechanisms (devices) are necessary to maintain safety and to avoid damage.

Disregard of this advice releases the manufacturer from product liability.

The sensor must be operated only within values specified in the catalog or datasheet.

Connection to power supply must be performed in accordance with safety instructions for electrical facilities and performed only by trained staff.

Insulation testing, welding and painting by electrostatic painting system may cause damage to a posichron® position sensor embedded within an equipment (cylinder, working machine etc). Disconnect the sensor unit in case of such treatment and plug in a protective shorting plug to ground all pins to cable shield. Refer to accessories for protective shorting plug.

Cable outputs must be installed in such a way that no moisture can get into the cable.

Do not connect / disconnect the sensor under tension.

Crossing the dew point must be avoided.

Protect the sensor against all strong electric or magnetic fields.

Do not expose the sensor or the position magnets to shocks or any kind of impacts.

posichron® position sensors must be mounted with unmagnetic screws.

Position magnets must be mounted always with unmagnetic screws.

Safety instructions



Explanation of used safety signs and signal words

DANGER

WARNING, Risk of Injury:

Indicates a potentially hazardous situation, which, if not avoided, could result in serious injury or property damage.

WARNING

WARNING, Risk of Personal Injury or Death:

Indicates a situation that can result in serious personal injury or death if not properly avoided.

CAUTION

WARNING, Risk of Personal Injury or Death:

Indicates a situation that can result in moderate personal injury or death if not properly avoided.

NOTICE

WARNING, Risk of Personal Injury:

Indicates a situation that can result in minor personal injury if not properly avoided.

WARNING, Risk of Property Damage:

Indicates a situation that can result in minor to major property damage if not properly avoided.

Intended use

The position sensor is intended for distance measurement, when properly mounted and used in the properly rated ambient atmospheric and technical conditions for which the sensor is designated.

Unintended use

The unintended use is when the sensor is used outside its specified technical and ambient atmospheric conditions or when improperly mounted.

Description

The purpose of position sensors is to transform position of a linear and guided movement into an electrical signal. Specifications of measuring range, environment, handling and connections as specified in the catalog, must be followed.

The catalog is part of this instruction manual. If the catalog is not available it may be requested by stating the respective model number.

posichron® is an absolute, contact-free and wear-free position measuring system. It is extremely rugged making it suitable even for applications where other measuring principles would fail. The availability of various constructions – rod, square profile and ultra-flat profile – means that the system can be adapted to suit all kinds of installation conditions.

The posichron® linear measuring system consists of a magnetostrictive wave guide and a movable magnet for determining position. The measuring principle of posichron® position sensors is based on two physical effects: the Wiedemann effect and the Villari effect.

To create the Wiedemann effect, a current impulse is sent through the posichron® positional sensor's wave guide. This current impulse generates a circular magnetic field which propagates at the speed of light around the wave guide. If this circular magnetic field makes contact with the magnetic field of the position magnet which is moved lengthways, a torsional mechanical-elastic density wave is triggered at the overlap area of the two magnetic fields as a result of magnetostriction. This wave propagates in the wave guide at approx. 2800 m/s.

The sensor head of the posichron® position sensor contains a detector which detects the arrival of this wave. The magneto-elastic Villari effect is used as the method of detection. The position between the detector coil and the magnet which can be moved lengthways along the posichron® sensor is determined by measuring the time difference between the electrical induction current impulse and the voltage pulse generated via the Villari effect in the detector coil (time-of-flight principle).

This time difference can be converted using various well-known methods into analog or digital output signals. The time-of-flight signals can however also be evaluated directly by commonly-available interface modules or counter and time-measuring devices.

Measurement rate depending on the measurement range	Measurement range	Measurement rate
	100 ... 1000 mm	2.0 ... 2.5 ms
	1000 ... 2000 mm	2.5 ... 4.3 ms
	2000 ... 4000 mm	4.3 ... 8.8 ms
	4000 ... 6000 mm	8.8 ms ... 13 ms

Remarks on environmental materials

In order to ensure a perfect magnetic signal of the position magnet all interferences caused by magnetic and/or magnetizable materials have to be avoided.

In principle it is absolutely recommended to use not magnetizable materials for the environment of the sensor. Likewise only not magnetizable screws should be used for the attachment of the position magnet.

Magnetic or magnetizable materials in the environment of the sensor can affect the signal of the position magnet in such a manner that the specified limit values are not kept. In addition it is possible that mismeasurements are caused by magnetic or magnetizable materials.

If the use of magnetizable material (rel. permeability $\mu_r \gg 1$) is inevitable, the sensor must be protected by suitable methods against magnetic fields ($H \geq 400 \text{ A/m}$). Pay attention to a sufficient distance of the sensor and the magnet to external magnetic fields with field strengths of $H \geq 400 \text{ A/m}$! The magnetic flux density of the environment may not exceed the value of $B = 0.5 \text{ mT}$ at the position of the magnet and the sensor rod. Magnetic and/or magnetizable materials should be absolutely avoided.

Materials with $\mu_r > 1$ are acceptable if $B_r \leq 0.5 \text{ mT}$ resp. $H_c \leq 500 \text{ A/m}$ at the same time, higher values than indicated can lead to failure of the position measurement.

To avoid a local increase of the field strength, additionally all edges near the sensor rod and the position magnet must be provided with a chamfer ($1 \times 45^\circ$).

Handling of the position magnets



Notes about the handling of the position magnets PCMAG

Regardless of the robust design the improper handling of the position magnets can cause reduction in signal quality, in extreme cases signal loss. Therefore a careful handling of the position magnets during installation and operation is recommended.

- **The storage and operation temperature of the position magnet must not exceed 100 °C.**
- **Extremely mechanical shock (drop) must be avoided.**
- **Do not expose the magnet to strong external magnetic fields ($H_{max.} < 140 \text{ kA/m}$, $\sim 1,8 \text{ kOe}$).**

Note: When using multiple magnets the distance between two magnets must be min. 70 mm to identify the single magnets definitely.

**Mounting
PCQAxx**

The sensor must be mounted with minimum two mounting sets PCQA-BFS1. For longer profiles one or more additional mounting sets are necessary in the middle of the profile.

**Mounting set
PCQA-BFS1 with
mounting clamps**

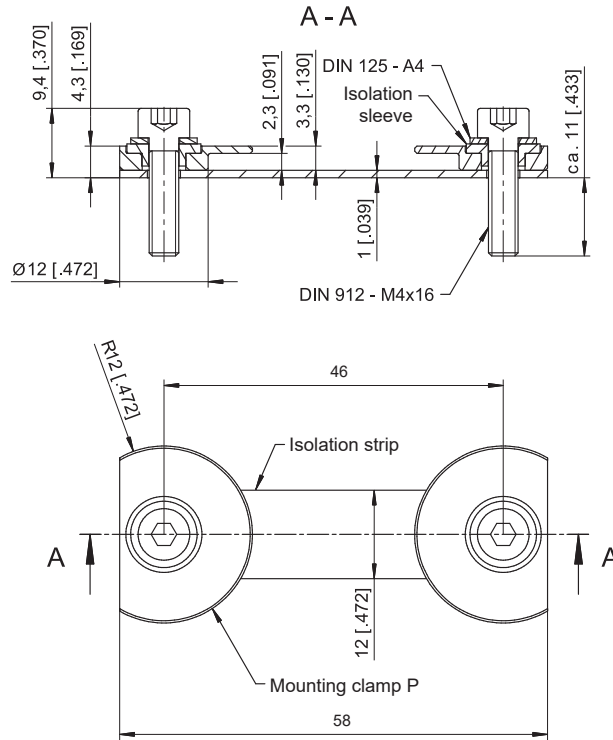

**Option -BFW
Mounting brackets
for PCQA22 and
PCQA24**

Note: The option -BFW can only be ordered with a new sensor, not separately!

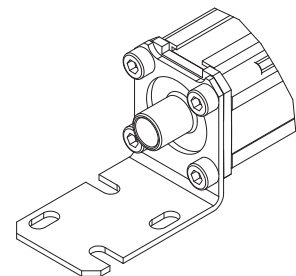
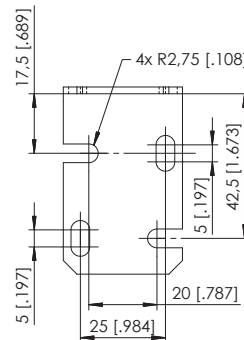
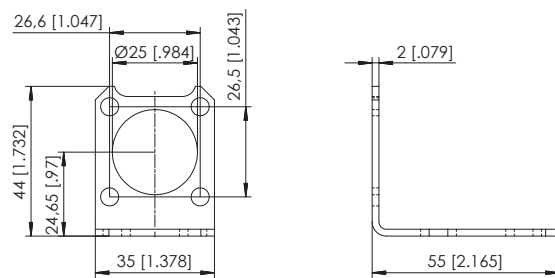
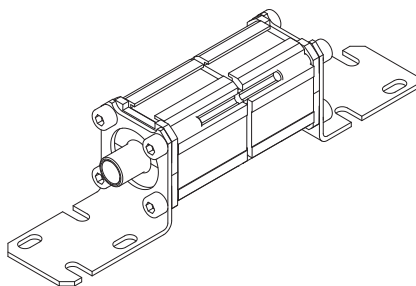

Dimensions in mm [inch]

Dimensions informative only.
For guaranteed dimensions consult factory.

**Mounting
PCFPxx**

The sensor must be mounted with minimum two mounting sets PCFPxx-BFS1. For longer profiles one or more additional mounting sets are necessary in the middle of the profile.

**Mounting set
PCFP23-BFS1
and
PCFP24-BFS1
with mounting
clamps**

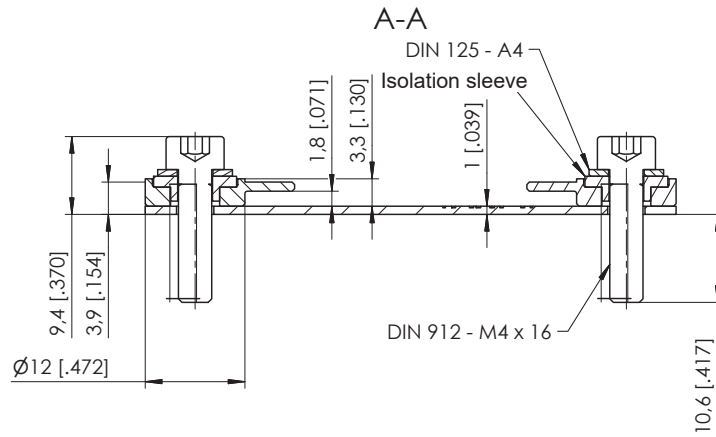

Dimensions in mm [inch]

Dimensions informative only.

For guaranteed dimensions consult factory.

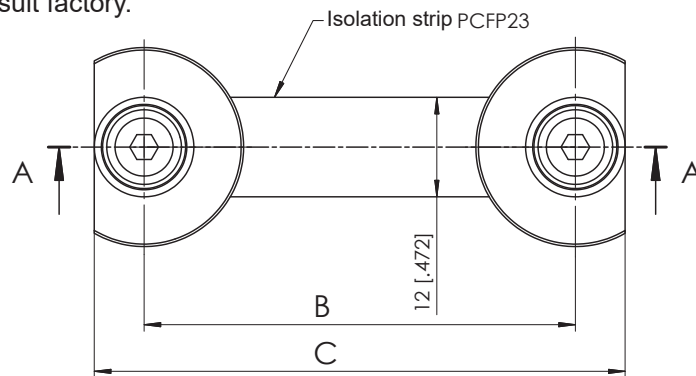

Dimensions for BFS1	posichron model	Dim. B [mm]	Dim. C [mm]
	PCFP23	52	64
	PCFP24	59	71

PCFP23 + PCMAG5

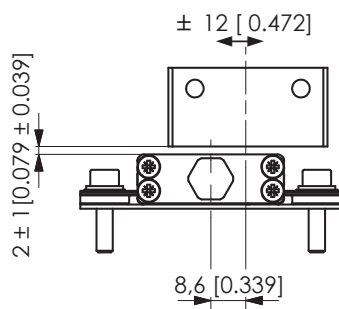

PCFP24 + PCMAG5

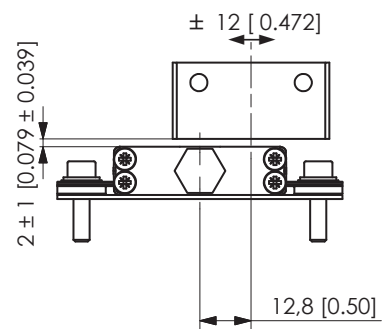

**Option -BFW
Mounting
brackets**

Note: The option -BFW can only be ordered with a new sensor, not separately!

For PCFP23

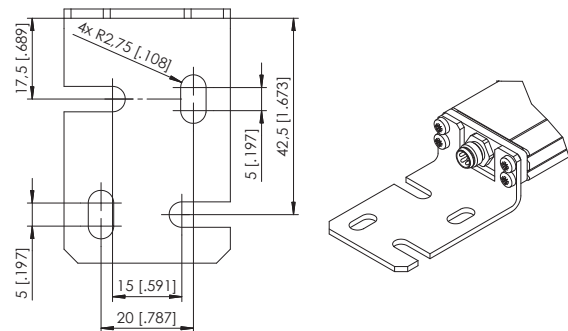
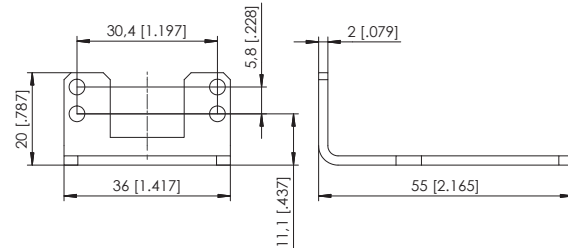
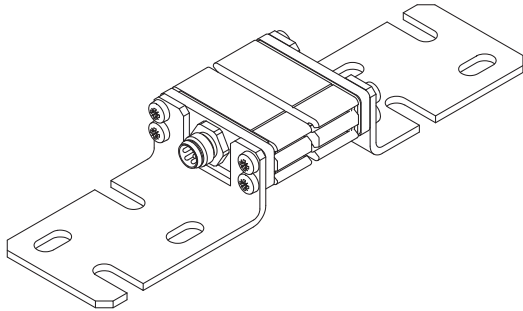

For PCFP24

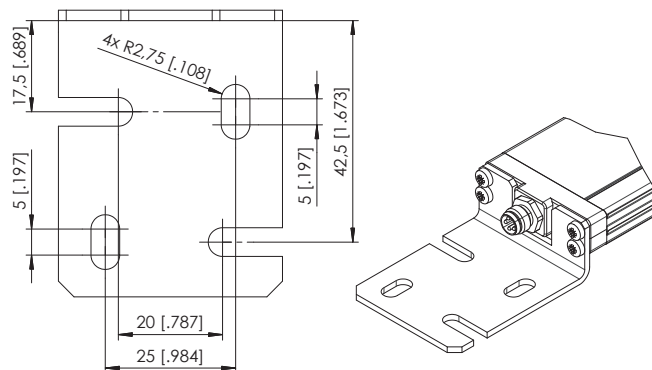
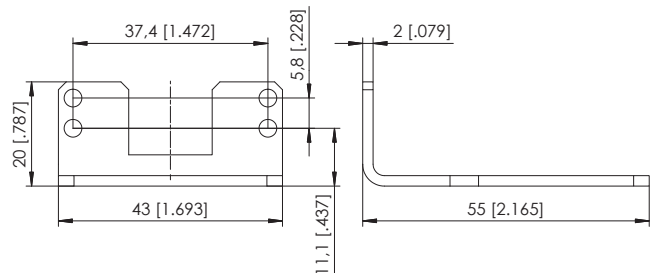
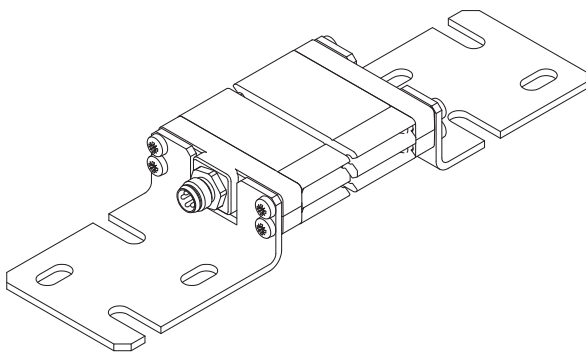

Dimensions in mm [inch]

Dimensions informative only.
For guaranteed dimensions consult factory.

Mounting PCFP25

The position sensor must be mounted with min. two mounting sets PCFP25-BFS1 (accessories). For longer profiles one or more additional mounting sets are necessary in the middle of the profile.

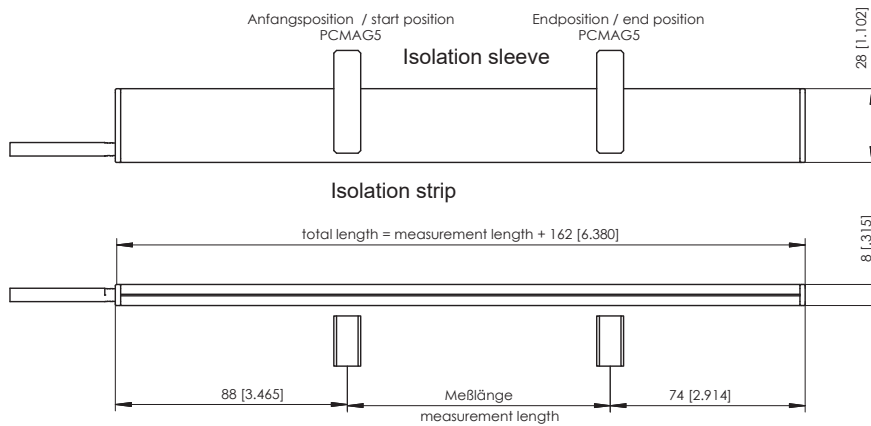

PCFP25 + PCMAG5

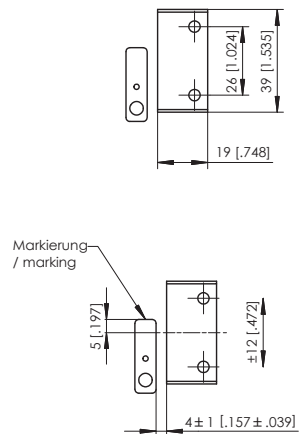

Redundant version

Horizontal arrangement

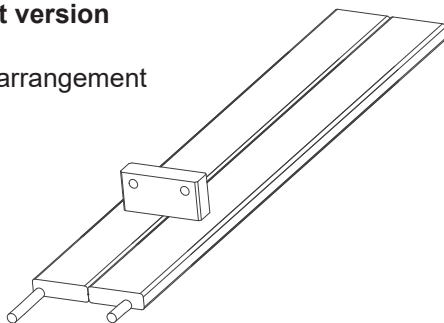

Vertical arrangement

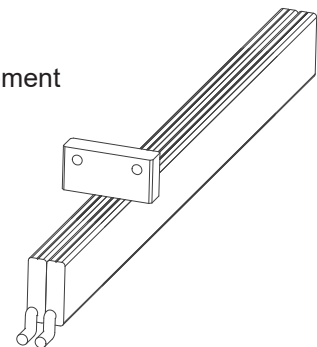

Mounting set PCFP25-BFS1

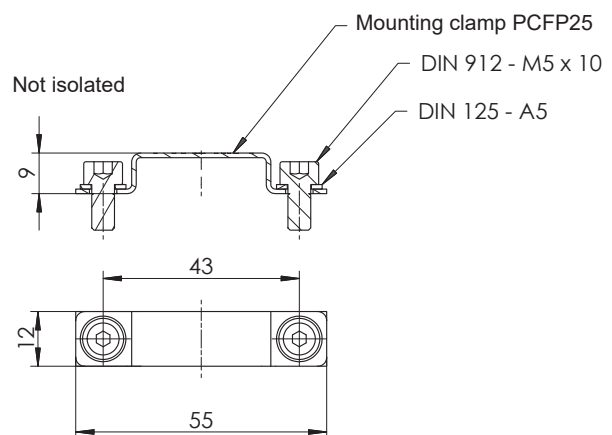
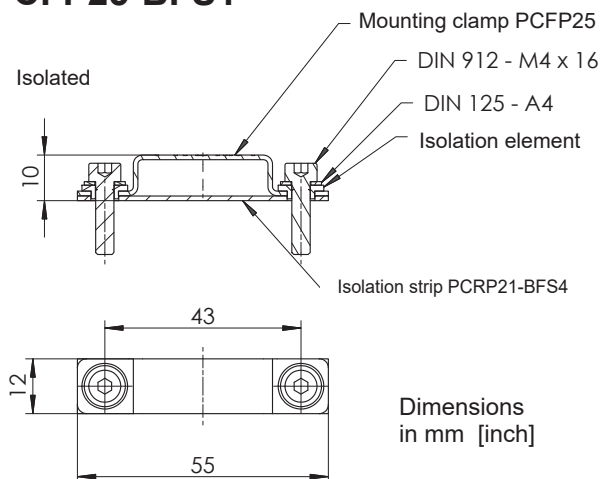

Dimensions
in mm [inch]

Dimensions informative only.
For guaranteed dimensions consult factory.

Mounting PCRP21

The sensor must be mounted with minimum two mounting sets PCRP21-BFS4. For longer profiles one or more additional mounting sets are necessary in the middle of the profile.

Mounting set PCRP21-BFS4 with mounting clamps

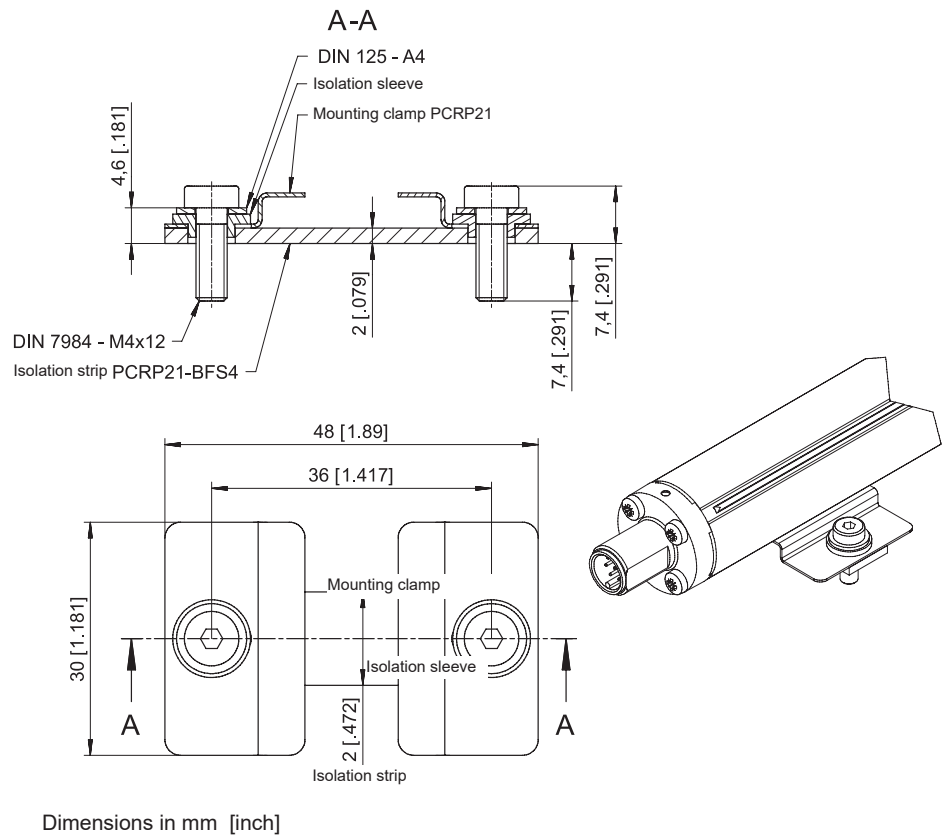

Mounting PCRP32

The sensor must be mounted in such a position that the magnet is located above the arrow label on the sensor housing!

**Mounting
PCSTxx**

The PCSTxx will be mounted via screw-thread M18 or ¾ inch.
The PCSTxx-M18 resp. PCSTxx-Z3/4 will be mounted via the flange thread (M18 x 1,5 bzw. ¾ inch-16UNF). The mounting face of the sensor head must fit plane to the surface of the hydraulic cylinder. To avoid any damage use a fitting nut for the flange thread. Tighten the sensor, a torque of 50 Nm must not be exceeded. Apply threadlocker to the the thread before mounting (recommended: LOCTITE 2701).

PCSTxx
Example PCST24

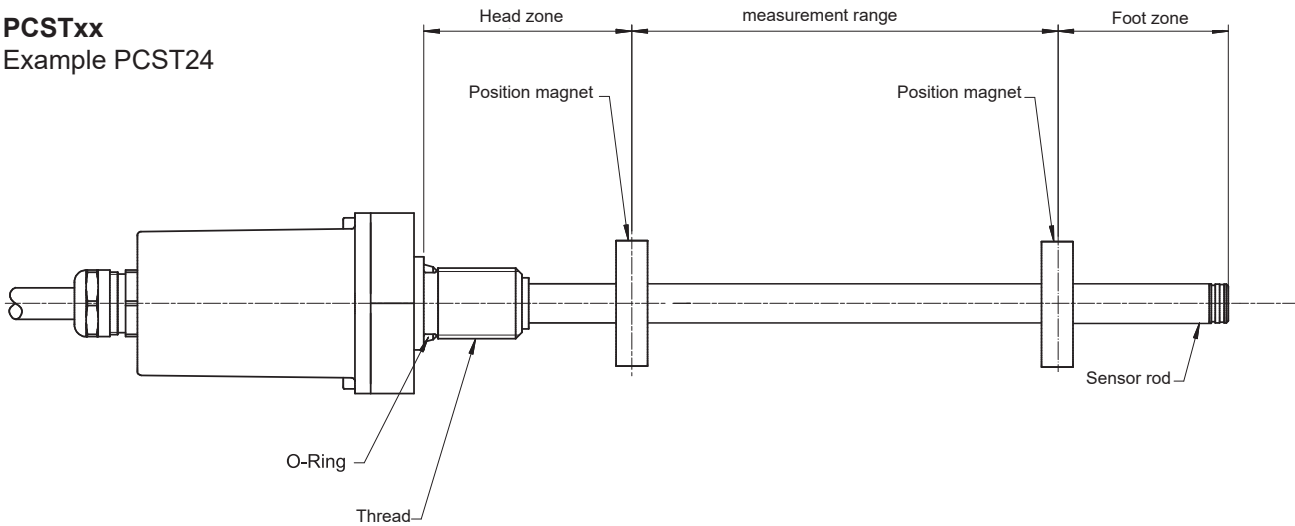

PCSTxx
Example PCST24 /
Hydraulic cylinder

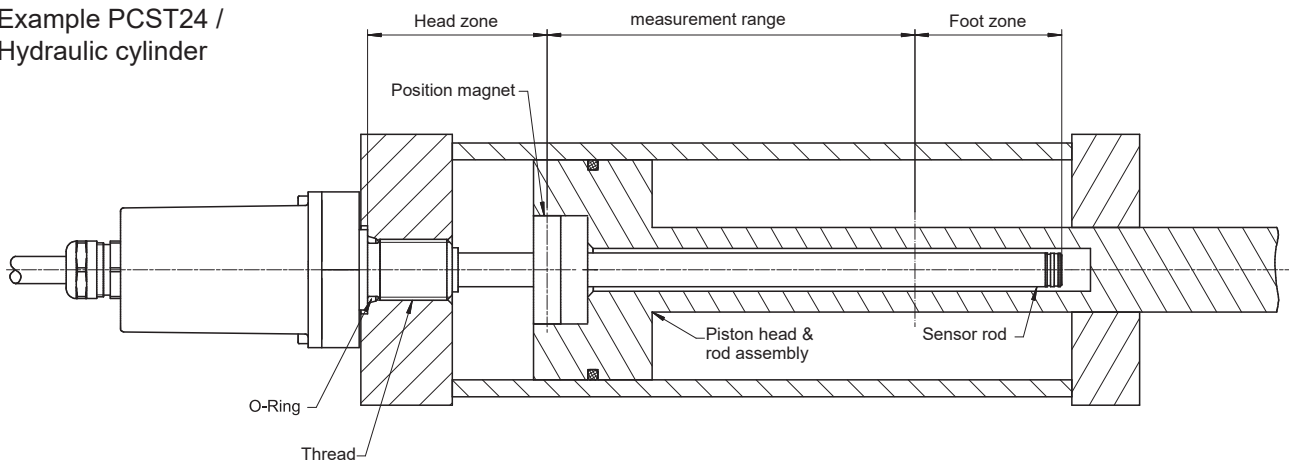

Dimensions in mm [inch]

Dimensions informative only.
For guaranteed dimensions consult factory.

Mounting
PCSTxx
(continuation)

Mounting hole
M18

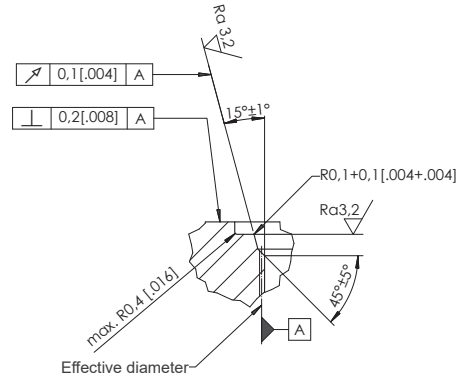

Drive hole and pivot M18 x 1,5 according to ISO 6149

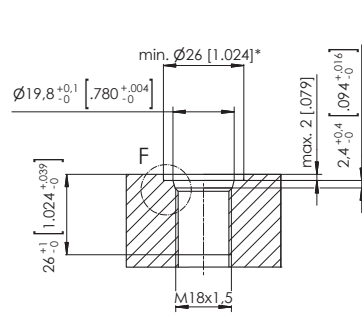

* Diameter of the plane area without marking ring

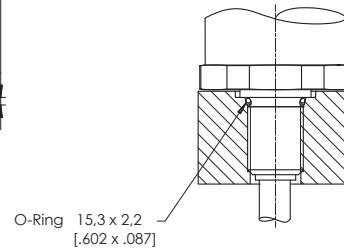

Mounting hole
3/4 inch

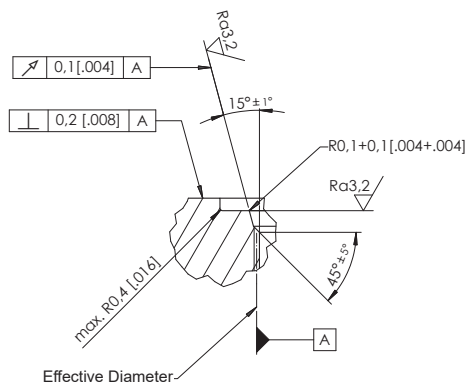

Drive hole according to ISO 11926-1 UN/UNF thread 2B according to ANSI B1.1/ISO 725
Pivot according to ISO 11926-2 and 3 UN/UNF thread 2A according to ANSI B1.1/ISO 725
Sealing by O-ring

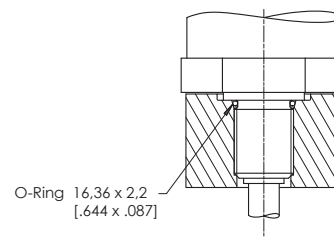
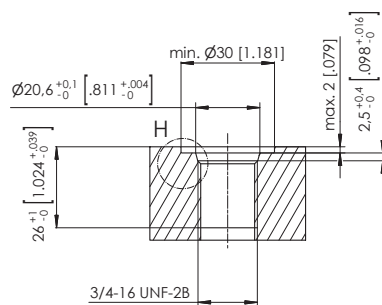

Dimensions in mm [inch]

Dimensions informative only.
For guaranteed dimensions consult factory.

**Mounting
PCST25-SV**

The application range for the rod-style PCSTxx is wide.
The PCST25 is the plug-in version - the sensor submerges completely within the hydraulic cylinder. There are 2 methods of mounting the PCST25-SV: from the right side, as shown on the following drawing, or from the left side (second drawing), where it has to be fastened with a grub screw.

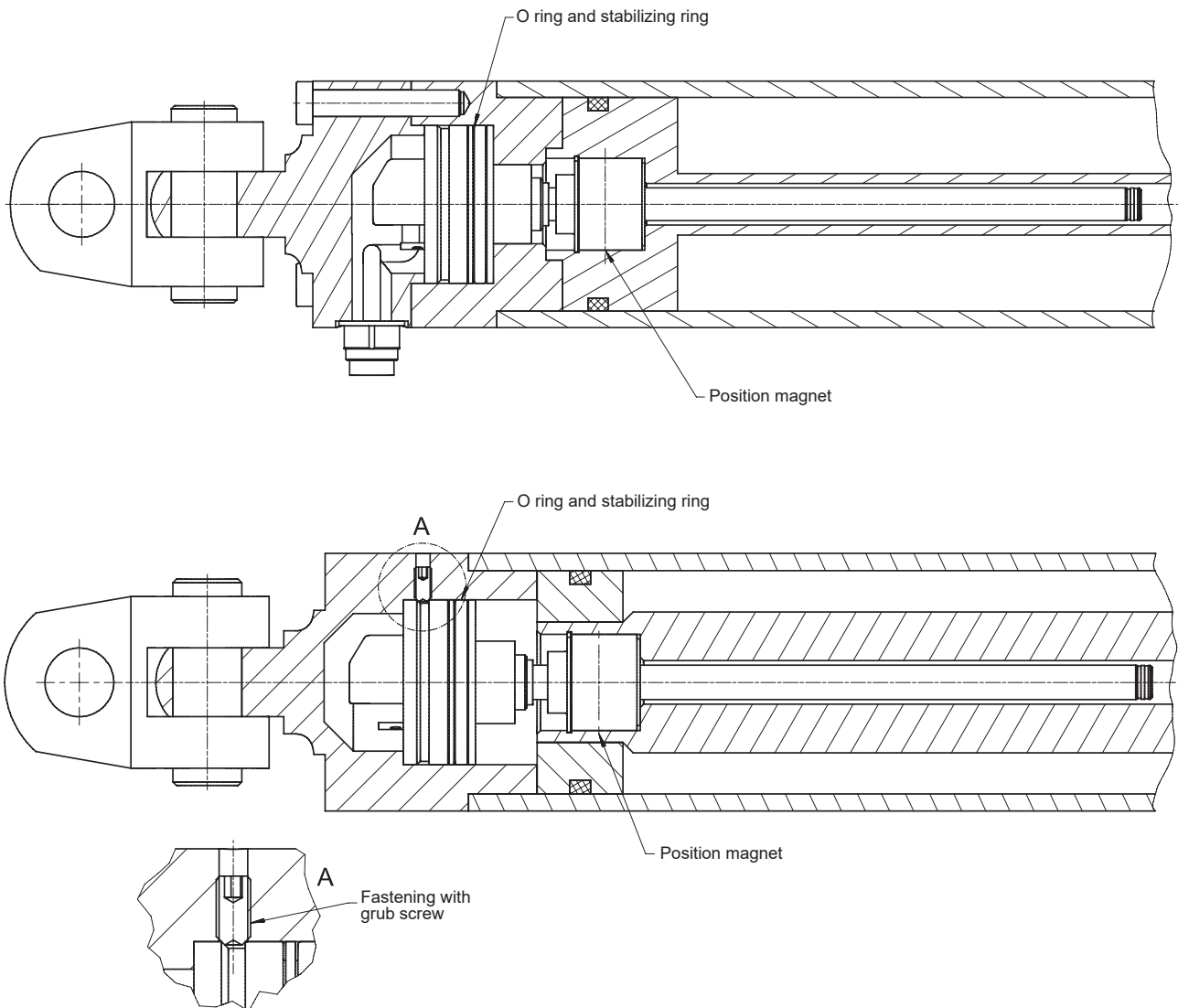

Dimensions in mm [inch]

Dimensions informative only.
For guaranteed dimensions consult factory.

Mounting
PCSTxx
(continuation)

The sensor rod of stainless steel is located within the bore of the piston rod. The size of bore must be selected depending on the pressure and the speed of the piston, however a size of at least 12,7 mm (½ inch). The maximum pressure of **400 bar** must not be exceeded.

At the retraction and the extension of the hydraulic cylinder a capacity of $V = l \cdot A$ (A: sensor cross section = 78,5 mm², l: piston stroke) must be displaced. If the displaced capacity isn't able to flow into or off fast enough a force has an effect on the sensor rod surface, perhaps the rod may break! In order to keep the effect of the force as small as possible, compensation holes of sufficient cross section must be planned, by those the capacity can flow through without generating unnecessarily high pressure on the sensor rod.

The position magnet as well as the sensor rod must be protected against wear by constructive methods. The position magnet must not drag along the sensor rod (especially when mounted in a hydraulic cylinder)! As an alternative to PCSTMAG2 a high-tensile and abrasion-poor special magnet is available (PCSTMAG2-G1/G2).

Non-magnetizable screws, distance bushes, circlips etc. must be used for mounting support. Use non-magnetic screws only to fix the position magnet! If a magnetic material is used a minimum distance of 8 mm (dimension "A") must be observed between the position magnet and the mounting flange resp. the hydraulic piston (see drawing below).

As an option is the distance bush "PCSTMAG2-BFS1" available.

Note: The magnetic leakage field of any environment at the position of the magnet must not exceed 0.5 mT.

Dimensions in mm [inch]

Dimensions informative only.
For guaranteed dimensions consult factory.

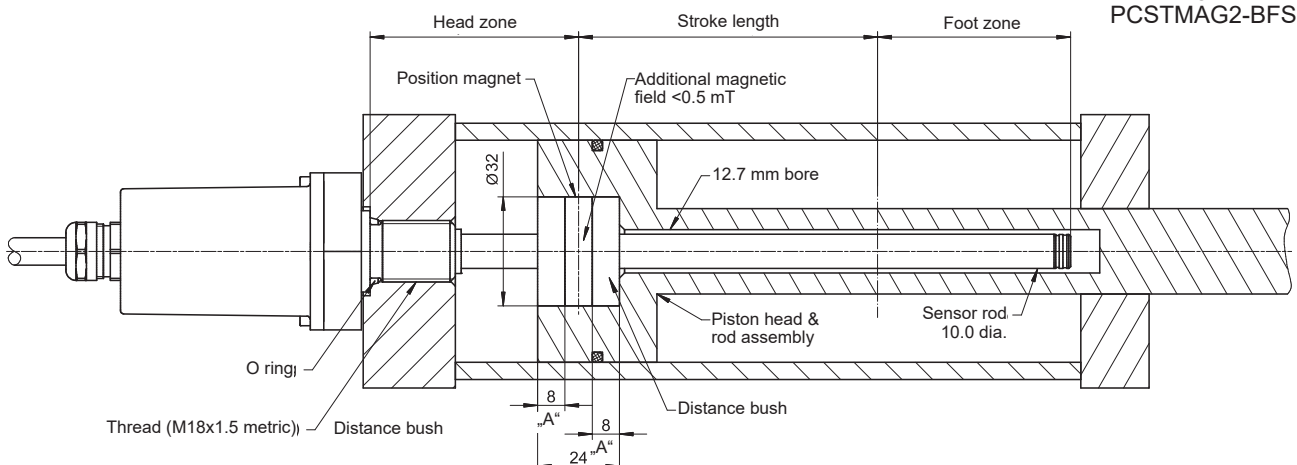
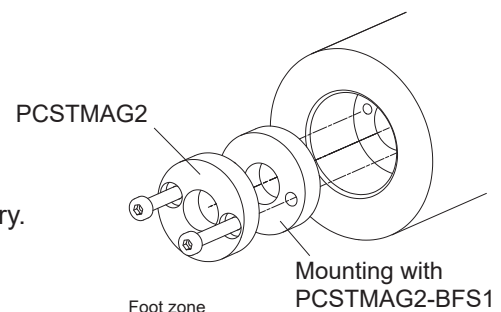

**Mounting
PCSTxx
(continuation)**

If mounted in horizontal position, sensors with more than 1000 mm range (length) must be provided with mechanical support at every 1000 mm and use the position magnet PCSTMAG1 (U-shape, see drawing)).

The rod of sensors with more than 1000 mm range and without mechanical support may have a sag or possibly break!

Example: Sensor support

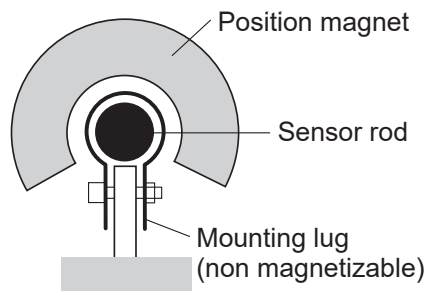

Therefore the sensor rod must not be pulled out of the bore of the hydraulic cylinder completely. A minimum length of 50 mm must remain in the piston resp. the piston rod.

**Mounting of
PCSTMAG2-
G1/G2**

Take both parts of the housing out of the bag, put it together and insert it into the designated bore of the cylinder piston. The correct position of the housing is very important (see drawing).

Please check that the four rubber pads are located in the four holes of the part of the housing. The four rubber pads ensure the horizontal compensation. The circlip DIN 472 fixes the housing of PCSTMAG2-G1. Check that the circlip fits into the groove completely. Assemble PCSTMAG2-G2 in the same way.

ISO diagram

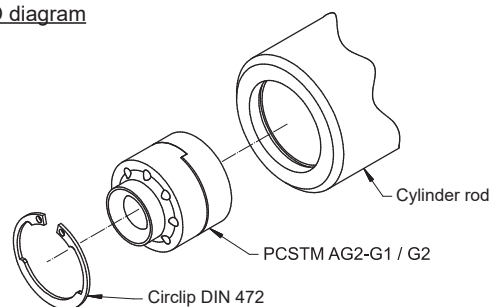

Section diagram

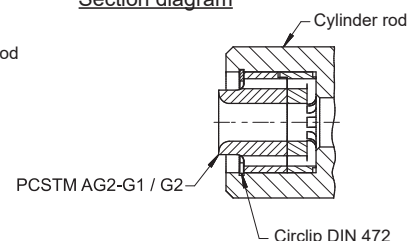

Mounting
PCST26
Separate
electronics
housing

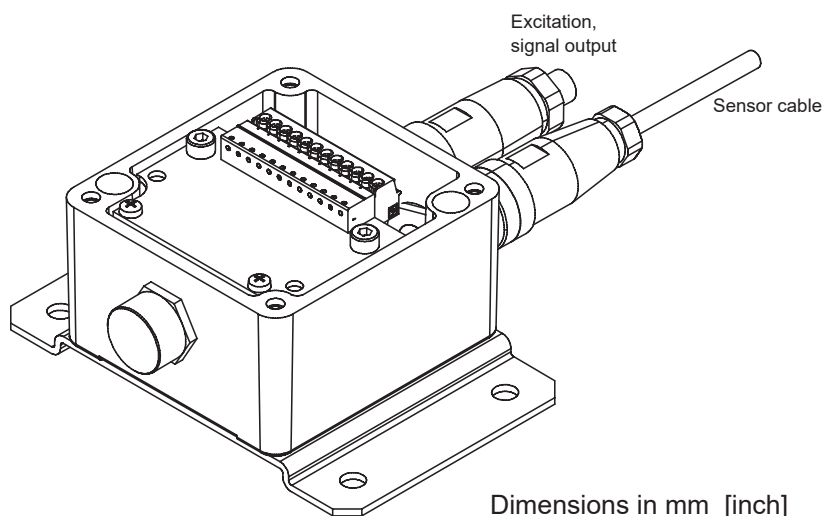
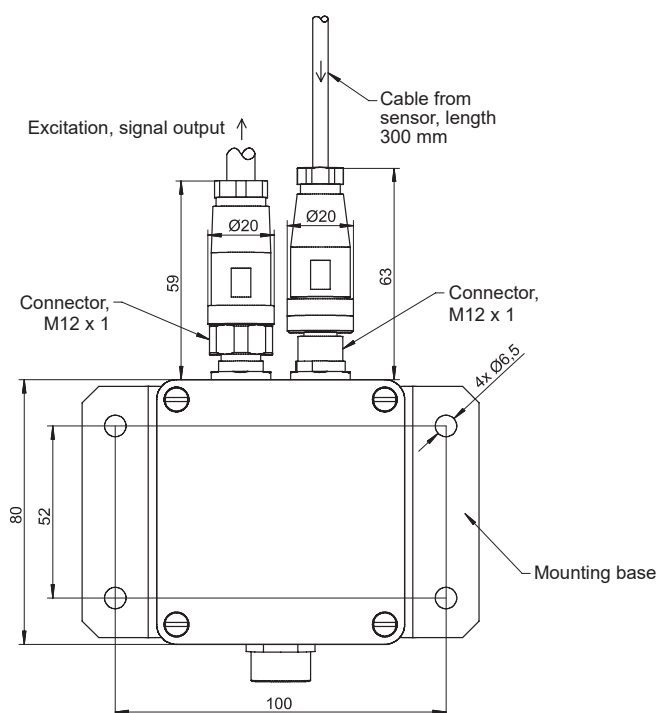
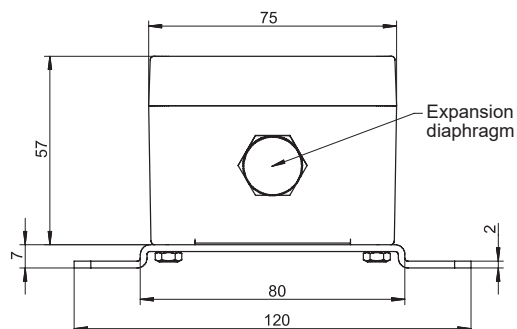

Dimensions in mm [inch]

Dimensions informative only.
For guaranteed dimensions consult factory.

**Mounting
PCST26**

**Separate
electronics**



Keep the cable between sensor and electronics housing well separated from power wiring, the minimum distance must be 500 mm.

To achieve a good noise rejection a low-pass filter with a cutoff frequency of 5 kHz is recommended at the input of the subsequent electronics.

To avoid potential compensation currents via the shield it is recommended to connect all facility units (components) with potential compensation lines.

Do only connect sensor and electronics housing with the same serial number!

Do not operate the system before the the sensor and the electronics housing have been connected and screwed together properly.

Do not connect or disconnect the electronics housing while the power is on!

Electromagnetic Compatibility (EMC)

The electromagnetic compatibility depends on wiring practice.
Recommended wiring:

- The profile housing sensor models can be mounted isolated using the appropriate mounting sets including an isolation strip.
- Use shielded twisted pair sensor cable.
- Keep sensor signal well separated from power wiring e.g. AC wiring, motor or relay. Use separate conduit or ducts for each.

If application includes highly electromagnetic interference emitting equipment like switch converter drives additional measures are recommended:

- Use a twisted pair cable, shielded per pair and common.
- Use shielded conduits or ducts connected to ground potential.

Repair and disposal



WARNING

Sensors and accessories have to be repaired and adjusted at ASM headquarters in Moosinning, Germany.

In order to avoid risk of injury and improper handling do not try to repair. No warranty or liability will be granted for opened sensors.

Disposal: Send metal parts for recycling!

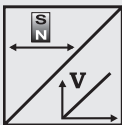
Signal conditioner U1, U2, U3, U8 Voltage output 	Excitation voltage	U1, U2: 18 ... 36 V DC; U3, U8: 10 ... 36 V
	Excitation current	Typical 23 mA at 24 V DC, Typical 46 mA at 12 V DC, 80 mA max.
	Output voltage	U1: 0 ... 10 V; U2: 0.5 ... 10 V; U3: 0 ... 5 V; U8: 0.5 ... 4.5 V
	Output current	2 mA max.
	Resolution	16 bit
	Stability (temperature)	$\pm 50 \times 10^{-6} / ^\circ\text{C}$ f.s.
	Protection	Reverse polarity, short circuit
	Output noise	0.5 mV _{RMS}
	Operating temperature	-40 ... +85 °C
	EMC	EN 61326-1:2013

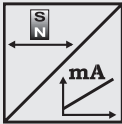
Signal conditioner I1, I2 Current output (3 wire) 	Excitation voltage	18 ... 36 V DC f. $R \leq 500 \Omega$ 10 ... 36 V DC f. $R \leq 100 \Omega$
	Excitation current	Typical 36 mA at 24 V DC, Typical 66 mA at 12 V DC, 80 mA max.
	Load resistor	500 Ω max.
	Output current I1	4 ... 20 mA, 30 mA max (at failure)
	Output current I2	0 ... 20 mA, 30 mA max (at failure)
	Resolution	16 bit
	Stability (temperature)	$\pm 50 \times 10^{-6} / ^\circ\text{C}$ f.s.
	Protection	Reverse polarity, short circuit
	Output noise	0.5 mV _{RMS}
	Operating temperature	-40 ... +85 °C
EMC	EN 61326-1:2013	

Signal diagram

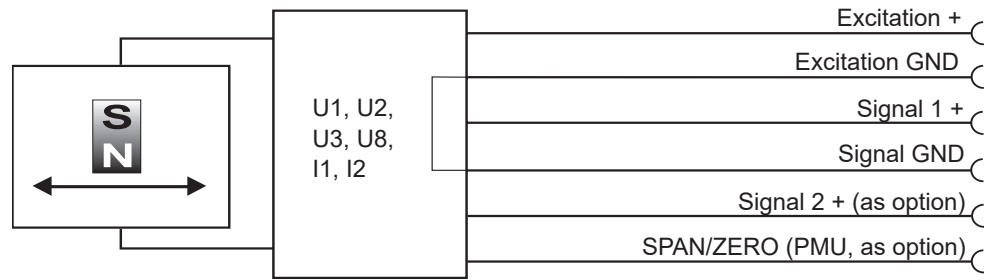

Signal wiring	Output signals U1, U2, U3, U8, I1, I2	Connector pin	Cable color
	Excitation +	1	white
	Excitation GND	2	brown
	Signal 1 +	3	green
	Signal GND	4	yellow
	Signal 2 + (as option)	5	grey
	SPAN/ZERO (PMU, as option)	6	pink

When using multiple magnets the distance between two magnets must be min. 70 mm to identify the single magnets definitely.

Connection
Mating connector

View to
sensor
connector

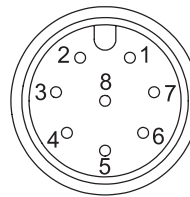

CONN-M12-8M

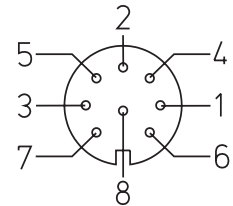

CONN-D8-8M

Output with 5-pin
connector M12 / cable

View to
sensor
connector

CONN-M12-5M

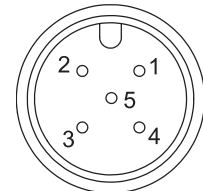

Signal wiring	Output signals	Connector pin	Cable color
	Excitation +	1	brown
	Signal 1 +	2	white
	GND	3	blue
	Signal 2 + (option)	4	black
	PMU optional	5	grey

Output with
4-pin
connector M8

View to
sensor
connector

CONN-M8-4M

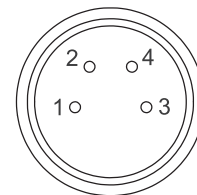

Signal wiring	Output signals	Connector pin
	Excitation +	1
	Excitation GND	2
	Signal +	3
	PMU optional	4

Diagnostic signal on error for U1, U2, U3, U8, I1, I2

The analog signal output in case of error

In case of error (e.g. magnet missing) the analog output signal will assume a state according to the following options:

	U1	U2	U3	U8	I1	I2
Alarm_HIGH (standard)	$U_{out} \geq 10,5 \text{ V}$	$U_{out} \geq 10,5 \text{ V}$	$U_{out} \geq 10 \text{ V}$	$U_{out} \geq 10 \text{ V}$	$I_{out} \geq 21 \text{ mA}$	$I_{out} \geq 21 \text{ mA}$
Alarm_LOW (.../U)	—	$U_{out} < 0,25 \text{ V}$ (U2/U)	—	$U_{out} < 0,25 \text{ V}$ (U8/U)	1,5 ... 2 mA (I1/U)	—
Alarm_HOLD (.../H)	-keeps last valid state- (U1/H)	-keeps last valid state- (U2/H)	-keeps last valid state- (U3/H)	-keeps last valid state- (U8/H)	-keeps last valid state- (I1/H)	-keeps last valid state- (I2/H)

Alarm_HIGH (standard)

The output voltage resp. the output current is at HIGH level (overrange).

Alarm_LOW

The output voltage resp. the output current is at LOW level (underrange).

Alarm_HOLD

The output voltage resp. the output current will keep the last valid state.

Settling time for analog outputs

Settling time for posichron® sensors with analog outputs:

<15 ms / 0 ... 90%

Option - PMU for analog outputs U1, U2, U3, U8, I1, I2

Programming of the start and end value by the customer

The option PMU allows to program the start value and the end value of the output range by a programming signal SPAN/ZERO available at the connector. This Signal SPAN/ZERO must be connected with GND via a push button, then position magnet of the sensor must be moved to the start resp. end position. Pushing the button between 1 and 4 seconds sets the actual position as start position, pushing the button more than 5 seconds sets the actual position as end position. The values will be stored and are available after switching off the sensor.

To reset the sensor to the factory values the button must be pushed when the sensor is switched on.

Synchronous serial interface SSI 	Output	RS422
	Excitation voltage	10 ... 36 V DC, residual ripple 10 mV _{SS}
	Excitation current	Typ. 22 mA at 24 V DC, typ. 46 mA at 12 V DC, 150 mA max.
	Clock frequency	100 kHz ... 1 MHz
	Code	Gray code, dual code
	Resolution	≥ 5 μm
	Delay between pulse trains	>25 μs
	Stability (temperature)	±50 x 10 ⁻⁶ / °C f.s.
	Operating temperature	-40 ... +85 °C
	Protection	Reverse polarity, short circuit
	EMC	EN 61326-1:2013

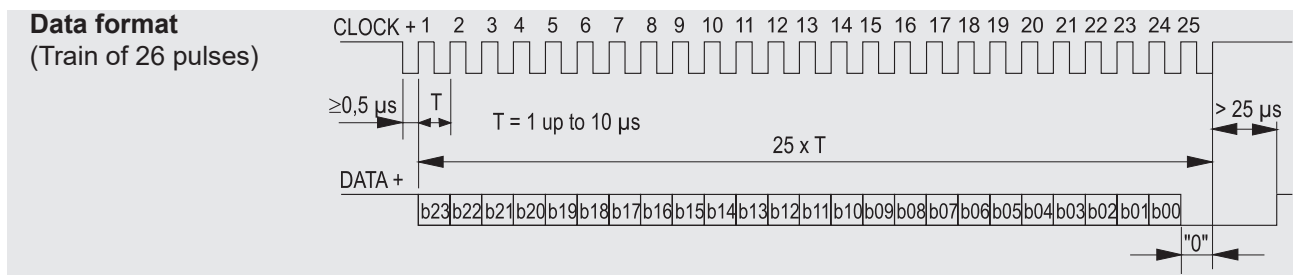

Signal diagram

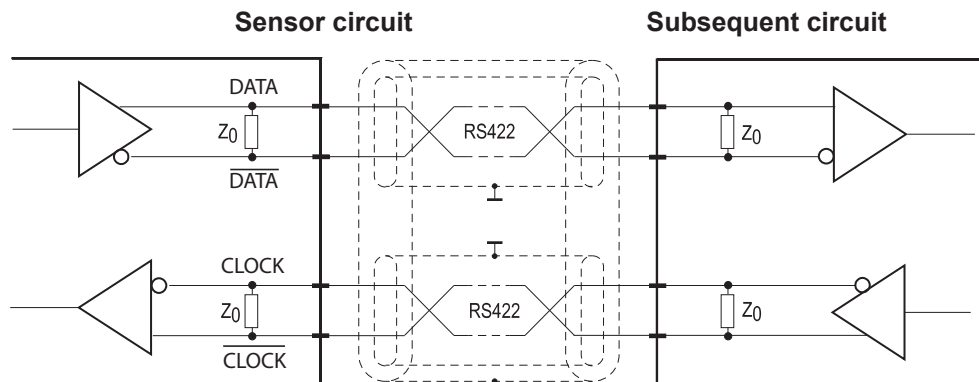

Cable length	Baud rate
50 m	100-1000 kHz
100 m	100-300 kHz

Note:
Extension of the cable length will reduce the maximum transmission rate.
The signals CLOCK/CLOCK and DATA/DATA must be connected in a twisted pair cable, shielded in pairs, the pairs also commonly shielded.

Signal wiring	Signal	Connector pin no.	Cable color
	Excitation +	1	white
	Excitation GND	2	brown
	CLOCK	3	green
	CLOCK	4	yellow
	DATA	5	grey
	DATA	6	pink

View to sensor connector

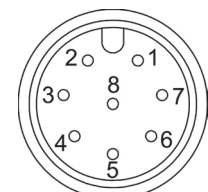

CONN-M12-8M

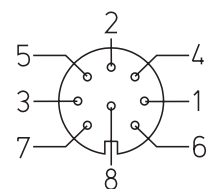

CONN-D8-8M

Error indication:

If the sensor cannot detect a magnet the position value will assume the maximum value (0xFFFFFFFF).

Description

CANopen Interface according to CANopen-Standards CiA DS301 DS406, for linear position sensors. Process data objects for position and CAM switches. Programmable parameters include Preset, Offset, Resolution, CAM switches, Transmission mode.

CANOP CANopen 	Communication profile	CANopen CiA 301 V 4.02, Slave
	Device profile	Encoder CiA 406 V 3.2
	Configuration services	Layer Setting Service (LSS), CiA Draft Standard 305 (transmission rate, node id)
	Error Control	Node Guarding, Heartbeat, Emergency Message
	Node ID	Default: 127; programmable via LSS or SDO
	PDO	1-4 TxPDO, 0 RxPDO, static mapping
	PDO Modes	Event-/Time triggered, Remote-request, Sync cyclic/acyclic
	SDO	1 server, 0 client
	CAM	8 cams
	Transmission rates	50 kBaud to 1 MBaud, default: 125 kBaud; programmable via LSS or SDO
	Bus connection	M12 connector, 5 pins
	Integrated terminating resistor	$R_T = 120 \Omega$, optional
	Bus, galvanic isolated	No

Specifications	Excitation voltage	18 ... 36 V DC
	Excitation current	typ. 20 mA at 24 V DC max. 80 mA
	Measuring rate	1 kHz (asynchronous)
	Stability (temperature)	$\pm 50 \times 10^{-6} / ^\circ\text{C}$ f.s. typical
	Repeatability	1 LSB
	Operating temperature	-40 ... +85 °C
	Protection	Reverse polarity, short circuit
	EMC	EN 61326-1:2013

When using multiple magnets the distance between two magnets must be min. 70 mm to identify the single magnets definitely!

Setup

Before connecting the sensor to the CAN-Bus the devices have to be checked for correct bitrate and unique node-IDs. Both parameters are configurable by Layer-Setting-Service (LSS) or by Service Data Object (SDO). After power-on the sensor will enter pre-operational state and send a boot-up message being ready for configuration by Service Data Objects. Parameters configured by the user can be stored nonvolatile by SAVE command. On receiving „NMT-Node-Start“ the sensor transits to operational state and starts process data transmission. When „Auto-Start“ is configured the sensor will automatically transit to operational after boot-up without a need for the Node-Start message.

Node monitoring is supported by Node Guarding and Heartbeat protocol. Node Guarding implements cyclic querying of the node status by the NMT-Master within the guard time window. The Heartbeat protocol provides automatic transmission of the node status (heartbeat message) by the slave within producer heartbeat time window.

Following the CAN example protocols included in this manual the sensor may be used without CANopen master device.



Warning notice

- Changing parameters may cause unexpected machine movement.
- Changing parameters may influence dependent parameters
- e.g. changing the resolution may have influence on position of CAM switches.
- Precautions have to be taken to avoid damage to human and machine parts!
- Change parameters only when machine is in a safe condition!

Service Data Object (SDO) COB-Id

Service data objects (SDO) provide a peer to peer communication between master and slave. The communication object identifier (COB) of the SDO is defined by the Node-Id.

SDO	COB-Id	Default COB-Id
Master to Slave	600h + Node-Id	67Fh
Slave to Master	580h + Node-Id	5FFh

Process Data Object (TPDO)

Real time data transfer is provided by Process Data Objects (PDO). The PDO mapping is fixed. The PDO COB-Id is by default setting derived from the Node-Id (Predefined Connection Set) but may be changed to application specific values by object PDO COB-Id 1800..1803 Sub-Index-1. DLC defines the length of the data field.

COB-Id	DLC	Data Frame	
		Byte0	Byte7
180h + Node-Id	length	Data Frame max 8 Byte	

Transmission behaviour of TPDO-1, -2, -4 is configurable by object PDO Communication Parameter 1800, 1801, 1803 sub-indices -1, -2, -3 and -5.

Transmission type example for TPDO-1	COB-Id 1800-1	Transmission Type 1800-2	Inhibit Time 1800-3	Event Timer [ms] 1800-5
Cyclic Asynchronous		FEh	-	1 .. 0FFFFh
Change of State		FEh	xx	0
Synchronous		N = 1 .. 240		-
Disable TPDO Enable TPDO	80 00 xx xx 00 00 xx xx	-		-

Transmission type «cyclic asynchronous» triggers TPDO-transmission periodically with a time period defined by the event timer.

Transmission type «change of state» will be enabled if the event timer is set to «0». This will trigger TPDO-transmission on change of the position value where «Inhibit time» defines a minimum time delay between consecutive TPDOs.

In «synch mode» a TPDO is transmitted on reception of a number of one or multiple SYNC commands. Enable or disable a TPDO by setting Bit 31 of the COB-Id '0' resp. '1' (Default: «0» Enabled).

Object Dictionary Communication Profile CiA 301

Object	Index [hex]	Sub-index	Access	Type	Default	Value Range / Note
Device type	1000	0	ro	U32	0A0196h	encoder profile ,406'
Error register	1001	0	ro	U8	0	
COB-ID-Sync	1005	0	rw	U32	80	
Manufacturer device name	1008	0	ro	String	-	
Manufacturer hardware version	1009	0	ro	String	-	
Manufacturer software version	100A	0	ro	String	-	
Guard time	100C	0	rw	U16	0	0 .. 7FFFh
Life time factor	100D	0	rw	U8	0	0 .. FFh
Save Settings	1010	1	w	U32	-	„save“ (65766173h)
Load Manufacturer Settings	1011	1	w	U32	-	„load“ (64616F6Ch)*
COB-ID-EMCY	1014	0	ro	U32	FFh	NodeID+80h
Producer heartbeat time	1017	0	rw	U16	0	0 .. 7FFFh
Identity Object VendorID	1018	1	ro	U32	252h	
Identity Object Product Code		2	ro	U32	-	
Identity Object Revision number		3	ro	U32	-	
Identity Object Serial number		4	ro	U32	-	
COB-ID Server->Client	1200	1	ro	U32	67Fh	SDO
COBID Client-> Sever		2	ro	U32	5FFh	SDO
PDO1 COB-ID	1800	1	rw	U32	1FFh	181h .. 1FFh
PDO1 Transmission-Type		2	rw	U8	FEh	0 .. FFh
PDO1 Inhibit time		3	rw	U16	0	0 .. 7FFFh
PDO1 Event timer		5	rw	U16	64h	0 .. 7FFFh
PDO2 COB-ID	1801	1	rw	U32	2FFh	281h .. 2FFh
PDO2 Transmission-Type		2	rw	U8	0	0 .. FFh
PDO2 Inhibit time		3	rw	U16	0	0 .. 7FFFh
PDO2 Event timer		5	rw	U16	0	0 .. 7FFFh
PDO3 COB-ID	1802	1	rw	U32	3FFh	381h .. 3FFh
PDO3 Transmission-Type		2	rw	U8	0	0 .. FFh
PDO3 Inhibit time		3	rw	U16	0	0 .. 7FFFh
PDO3 Event timer		5	rw	U16	0	0 .. 7FFFh
PDO4 COB-ID	1803	1	rw	U32	4FFh	481h .. 4FFh
PDO4 Transmission-Type		2	rw	U8	0	0 .. FFh
PDO4 Inhibit time		3	rw	U16	0	0 .. 7FFFh
PDO4 Event timer		5	rw	U16	0	0 .. 7FFFh

Object	Index [hex]	Sub-index	Access	Type	Default	Value Range / Note
TPDO1-Mapped Object1	1A00	1	ro	U32	60200120h	
TPDO1-Mapped Object2		2	ro	U32	60300110h	
TPDO1-Mapped Object3		3	ro	U32	63000108h	
TPDO1-Mapped Object4		4	ro	U32	20300008h	
TPDO2-Mapped Object1	1A01	1	ro	U32	60200220h	
TPDO2-Mapped Object2		2	ro	U32	60300210h	
TPDO2-Mapped Object3		3	ro	U32	63000208h	
TPDO2-Mapped Object4		4	ro	U32	20300008h	
TPDO3-Mapped Object1	1A02	1	ro	U32	60200320h	
TPDO3-Mapped Object2		2	ro	U32	60300310h	
TPDO3-Mapped Object3		3	ro	U32	63000308h	
TPDO3-Mapped Object4		4	ro	U32	20300008h	
TPDO4-Mapped Object1	1A03	1	ro	U32	60200420h	
TPDO4-Mapped Object2		2	ro	U32	60300410h	
TPDO4-Mapped Object3		3	ro	U32	63000408h	
TPDO4-Mapped Object4		4	ro	U32	20300008h	
NMT-Startup	1F80	0	rw	U32	0	0.8

Device Profile CiA 406

Object	Index [hex]	Sub-index	Access	Type	Default	Value Range / Note
Manufacturer specific						
Node-ID	2000		rw		127	1...127
Bitrate	2010		rw		4	0..4, 6
Error	2030		ro			
Hysteresis	2040		rw			
Number of Positions	2080		rw		1	1..4
User Offset	2100		rw		0	0... 0FFFFh
Filter	2102		rw		0	1...255
Linear Encoder CiA406						
Operating Parameters	6000		rw		0	
Total Measuring Range	6002		rw			
Position Step Setting	6005	1	rw		50 µm	
Speed Step Setting	6005	2	rw		1mm/s	
Preset Values	6010	1...4	rw		0	
Position Values	6020	1...4	ro		0	
Speed Values	6030	1...4	ro		0	
Cyclic Timer	6200		rw		100	
Profile and SW Version	6507		ro			
Serial Number	650B		ro			
Offset values	650C	1...4	ro		0	
CAM CiA406						
Cam state register	6300	1...4	ro			
Cam enable register	6301	1...4	rw		0	
Cam polarity register	6302	1...4	rw		0	
Cam 1-8 low limit	6310... 6317	1...4	rw		0	
Cam 1-8 high limit	6320... 6327	1...4	rw		0	
Cam 1-8 hysteresis	6330... 6337	1...4	rw		0	

Operating Parameters Bit Code

15	4	3	2	1	0
						sfc		cs
MSB								LSB

cs = 0/1 Code sequence CW/CCW
sfc = 0/1 Scaling function disabled/enabled

Process Data Object (TPDO) Mapping

TPDO	COB-Id	DLC	Byte 0	Data Frame						Byte 7
TPDO-01 ... TPDO-04	180h +Node-Id	8	Position (4 Byte)				Speed (2 Byte)		CAM Status	Error
			LSB	MSB	LSB	MSB	1 Byte	1 Byte

CAM State Data Format

8 Bit CAM State Register							
b7	b6	b5	b4	b3	b2	b1	b0
CAM 8	CAM 7	CAM 6	CAM 5	CAM 4	CAM 3	CAM 2	CAM 1

TPDO Default Settings

TPDO	Default COB-Id	Default Transmission Type
TPDO1: 1st magnet Position, Speed, CAM Status, Error	1FFh	Cyclic Asynchronous 100ms
TPDO2: 2nd magnet Position, Speed, CAM Status, Error	2FFh	Sync Mode
TPDO3: 3rd magnet Position, Speed, CAM Status, Error	3FFh	Sync Mode
TPDO4: 4th magnet Position, Speed, CAM Status, Error	4FFh	Sync Mode

Bit Rate (Object 2010)

Bit Rate Index	Bit Rate [kbit/s]
0	1000
1	800
2	500
3	250
4	125
6	50

PDO Error-Byte	Error	Meaning
	0	Normal operation
	1 ... n	Malfunction, number of missing position magnets according to index 2080 (number of positions)
	81 ... 8n	to many position magnets

Examples

Example protocols are prepared using the IXXAT USB-to-CAN PC-Interface with CAN-Monitor „miniMon“ (IXXAT Automation GmbH, D-88250 Weingarten). These examples enable the user to configure and to run the CANopen slaves from a host PC without using a CANopen master ECU. The miniMon-screen has the configuration and status window at left side, a receive message window and a transmit message window below.

Configuration Example 1 - screenshot

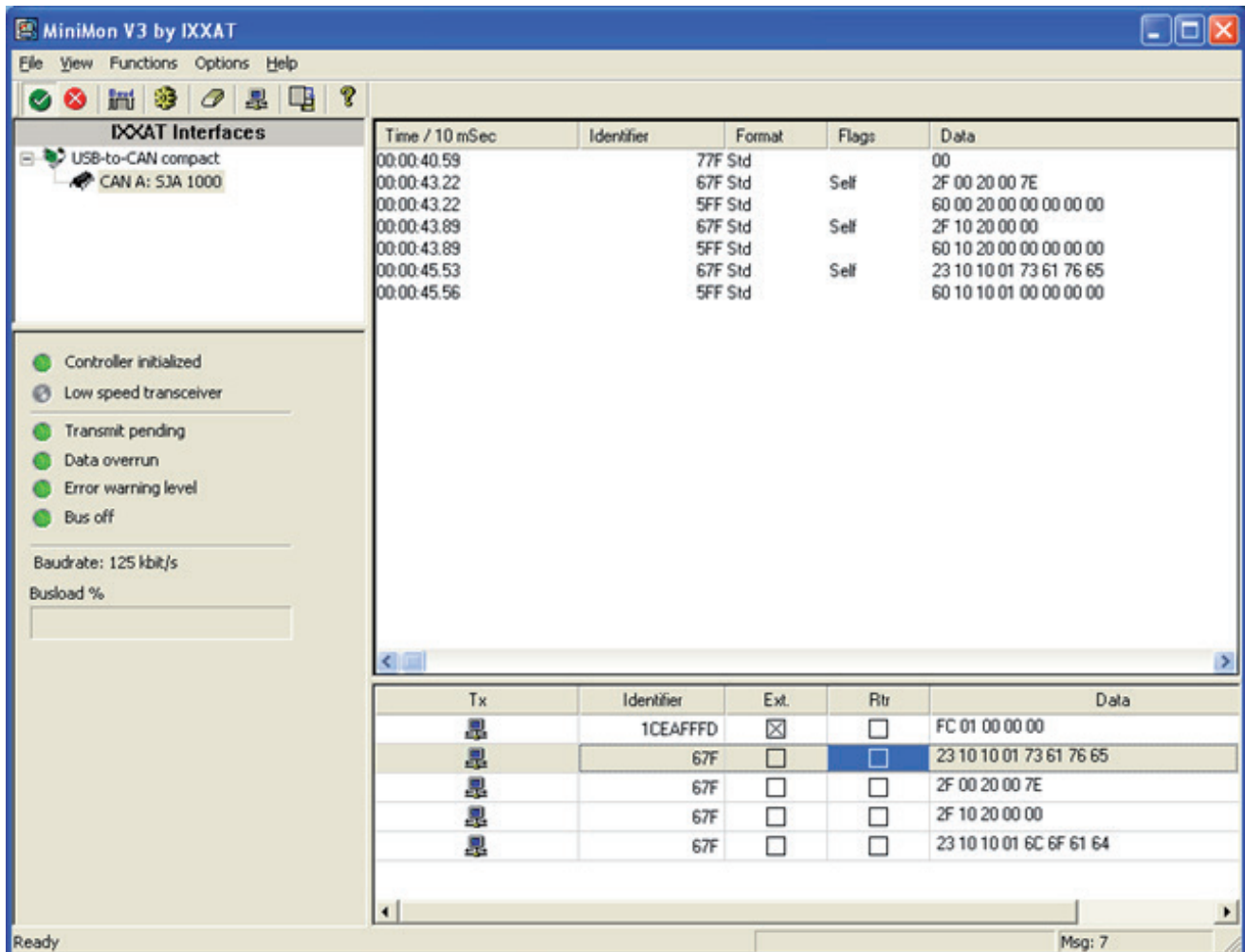

The screenshot shows the MiniMon V3 by IXXAT software interface. The window title is "MiniMon V3 by IXXAT". The menu bar includes "File", "View", "Functions", "Options", and "Help". The toolbar contains various icons for control and help.

IXXAT Interfaces

- USB-to-CAN compact
 - CAN A: SJA 1000

Status Indicators:

- Controller initialized
- Low speed transceiver
- Transmit pending
- Data overrun
- Error warning level
- Bus off

Baudrate: 125 kbit/s
Busload %

Receive Message Log:

Time / 10 mSec	Identifier	Format	Flags	Data
00:00:40.59	77F Std			00
00:00:43.22	67F Std		Self	2F 00 20 00 7E
00:00:43.22	5FF Std			60 00 20 00 00 00 00 00
00:00:43.89	67F Std		Self	2F 10 20 00 00
00:00:43.89	5FF Std			60 10 20 00 00 00 00 00
00:00:45.53	67F Std		Self	23 10 10 01 73 61 76 65
00:00:45.56	5FF Std			60 10 10 01 00 00 00 00

Transmit Message Log:

Tx	Identifier	Ext.	Rtr	Data
<input checked="" type="checkbox"/>	1CEAFFFD	<input checked="" type="checkbox"/>	<input type="checkbox"/>	FC 01 00 00 00
<input checked="" type="checkbox"/>	67F	<input type="checkbox"/>	<input checked="" type="checkbox"/>	23 10 10 01 73 61 76 65
<input checked="" type="checkbox"/>	67F	<input type="checkbox"/>	<input type="checkbox"/>	2F 00 20 00 7E
<input checked="" type="checkbox"/>	67F	<input type="checkbox"/>	<input type="checkbox"/>	2F 10 20 00 00
<input checked="" type="checkbox"/>	67F	<input type="checkbox"/>	<input type="checkbox"/>	23 10 10 01 6C 6F 61 64

Ready Msg: 7

Configuration Example 1 - detailed explanation

The example shows the Sensor responding on POWER ON with the Boot-Up message. By SDO message the node-Id and the baud rate will be changed to 7Eh and 1000kbit/s. Finally the host sends an SDO „SAVE“ to store the configuration nonvolatile.

Note: Changes of of node-Id and baud rate will become effective on next POWER ON sequence. So the SAVE command has to address the old SDO-COB-Id.

Screen Shot Explanation:

Time / 10 mSec	Identifier	Format	Flags	Data
00:00:40.59	<i>Boot-Up message</i>	77F StJ		00
00:00:43.22	<i>Set node Id to 7E</i>	67F StJ	Self	2F 00 20 00 7E
00:00:43.22	<i>Response</i>	5FF StJ		60 00 20 00 00 00 00 00
00:00:43.89	<i>Set baud rate to 1000kbit/s</i>	67F StJ	Self	2F 10 20 00 00
00:00:43.89	<i>Response</i>	5FF StJ		60 10 20 00 00 00 00 00
00:00:45.53	<i>SAVE</i>	67F StJ	Self	23 10 10 01 73 61 76 65
00:00:45.56	<i>Response</i>	5FF StJ		60 10 10 01 00 00 00 00

Configuration Example 2 - screenshot

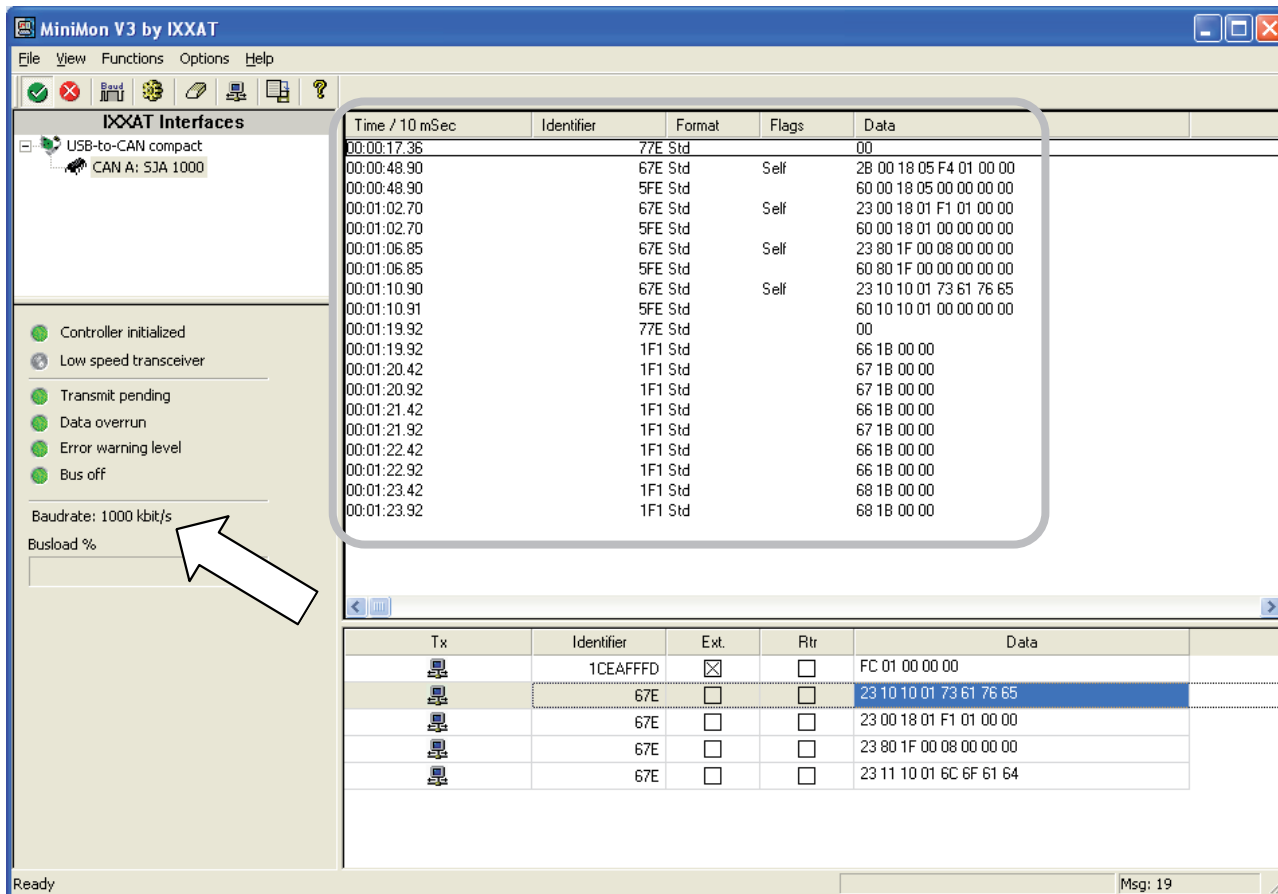

The screenshot shows the MiniMon V3 by IXXAT software interface. On the left, under 'IXXAT Interfaces', 'CAN A: SJA 1000' is selected. Below this, several status indicators are shown with green circles, including 'Controller initialized', 'Low speed transceiver', 'Transmit pending', 'Data overrun', 'Error warning level', and 'Bus off'. The 'Baudrate: 1000 kbit/s' and 'Busload %' fields are visible, with a white arrow pointing to the 'Busload %' field.

The main window displays a table of captured CAN messages:

Time / 10 mSec	Identifier	Format	Flags	Data
00:00:17.36		77E Std		00
00:00:48.90		67E Std	Self	26 00 18 05 F4 01 00 00
00:00:48.90		5FE Std		60 00 18 05 00 00 00 00
00:01:02.70		67E Std	Self	23 00 18 01 F1 01 00 00
00:01:02.70		5FE Std		60 00 18 01 00 00 00 00
00:01:06.85		67E Std	Self	23 80 1F 00 08 00 00 00
00:01:06.85		5FE Std		60 80 1F 00 00 00 00 00
00:01:10.90		67E Std	Self	23 10 10 01 73 61 76 65
00:01:10.91		5FE Std		60 10 10 01 00 00 00 00
00:01:19.92		77E Std		00
00:01:19.92		1F1 Std		66 18 00 00
00:01:20.42		1F1 Std		67 18 00 00
00:01:20.92		1F1 Std		67 18 00 00
00:01:21.42		1F1 Std		66 18 00 00
00:01:21.92		1F1 Std		67 18 00 00
00:01:22.42		1F1 Std		66 18 00 00
00:01:22.92		1F1 Std		66 18 00 00
00:01:23.42		1F1 Std		68 18 00 00
00:01:23.92		1F1 Std		68 18 00 00

Below the main table, a 'Tx' table shows the configuration for transmitted messages:

Tx	Identifier	Ext.	Rtr	Data
<input type="checkbox"/>	1CEAFFFD	<input checked="" type="checkbox"/>	<input type="checkbox"/>	FC 01 00 00 00
<input checked="" type="checkbox"/>	67E	<input type="checkbox"/>	<input type="checkbox"/>	23 10 10 01 73 61 76 65
<input checked="" type="checkbox"/>	67E	<input type="checkbox"/>	<input type="checkbox"/>	23 00 18 01 F1 01 00 00
<input checked="" type="checkbox"/>	67E	<input type="checkbox"/>	<input type="checkbox"/>	23 80 1F 00 08 00 00 00
<input checked="" type="checkbox"/>	67E	<input type="checkbox"/>	<input type="checkbox"/>	23 11 10 01 6C 6F 61 64

The status bar at the bottom left shows 'Ready' and the bottom right shows 'Msg: 19'.

Configuration Example 2 - detailed explanation

The message window shows the slave responding on POWER ON with the Boot-Up message on new node-id 7Eh. Event timer of PDO1 is changed to 500ms and COB-Id of PDO1 is changed to 1F1h. Finally „Autostart“ is activated (automatic transition to operational) and the configuration stored nonvolatile with „SAVE“. On POWER OFF / POWER ON the slave starts sending PDOs asynchronously with the new COB-Id after the Boot-Up message.

Screenshot explanation:

Time / 10 mSec	Identifier	Format	Flags	Data
00:00:17.36	<i>Boot-Up Message</i>	77E Std		00
00:00:48.90	<i>Set PDO1 Event Timer 500</i>	67E Std	Self	2B 00 18 05 F4 01 00 00
00:00:48.90	<i>Response</i>	5FE Std		60 00 18 05 00 00 00 00
00:01:02.70	<i>Set PDO1 COB-Id to 1F1</i>	67E Std	Self	23 00 18 01 F1 01 00 00
00:01:02.70	<i>Response</i>	5FE Std		60 00 18 01 00 00 00 00
00:01:06.85	<i>Set Autostart</i>	67E Std	Self	23 80 1F 00 08 00 00 00
00:01:06.85	<i>Response</i>	5FE Std		60 80 1F 00 00 00 00 00
00:01:10.90	<i>SAVE</i>	67E Std	Self	23 10 10 01 73 61 76 65
00:01:10.91	<i>Response .. POWER OFF</i>	5FE Std		60 10 10 01 00 00 00 00
00:01:19.92	<i>Boot Up on POWER ON</i>	77E Std		00
00:01:19.92	<i>Cyclic PDO Transfer</i>	1F1 Std		66 1B 00 00
00:01:20.42	<i>on Power On</i>	1F1 Std		67 1B 00 00
00:01:20.92	...	1F1 Std		67 1B 00 00
00:01:21.42	...	1F1 Std		66 1B 00 00
00:01:21.92	...	1F1 Std		67 1B 00 00
00:01:22.42	...	1F1 Std		66 1B 00 00
00:01:22.92	...	1F1 Std		66 1B 00 00
00:01:23.42	...	1F1 Std		68 1B 00 00
00:01:23.92	...	1F1 Std		68 1B 00 00

CAM function

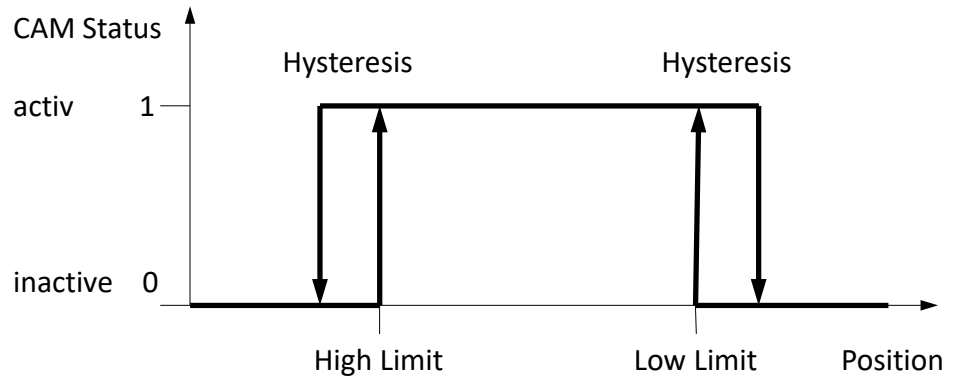

Signal wiring	Signal	Connector pin no.
	Shield	1
	Excitation +	2
	GND	3
	CAN-H	4
	CAN-L	5

View to sensor connector

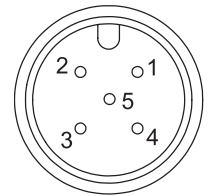

CAN bus wiring

Connect the device by a T-connector to the CAN trunk line. Total length of stubs should be minimized. Do not use single stub lines longer than 0.5 m. Connect terminating resistors 120 Ohm at both ends of the trunk line.

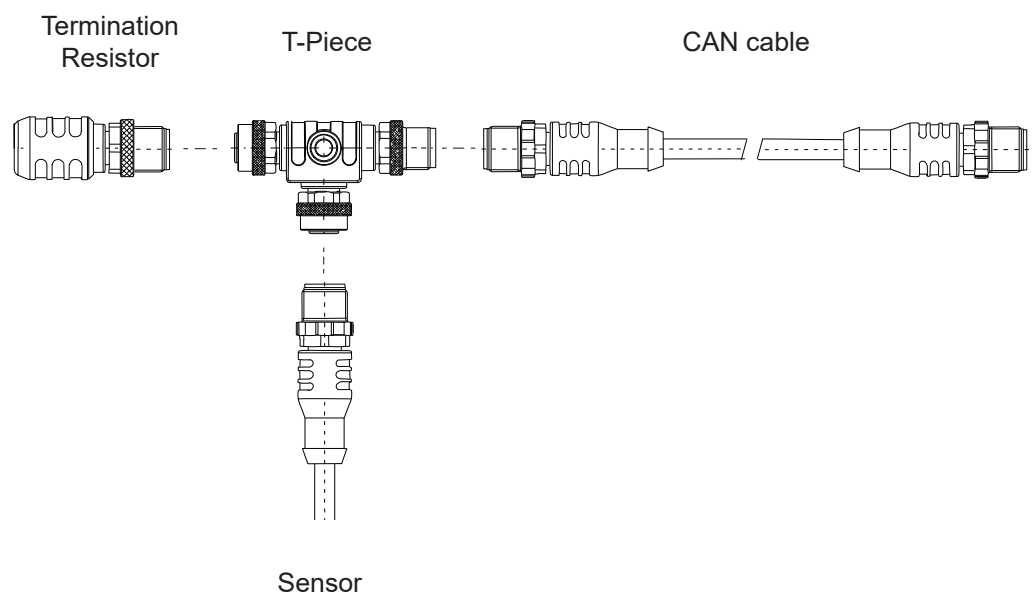

Description

Linear encoder according to standard SAE J1939. Configuration of operating parameters by proprietary-A-Message (peer-to-peer connection). Process data exchange by proprietary-B-Message (broadcast).

CANJ1939 CAN SAE J1939 	CAN specification	ISO 11898, Basic and Full CAN 2.0 B
	Transceiver	24V-compliant, not isolated
	Communication profile	SAE J1939
	Baud rate	250 kbit/s
	Internal termination resistor	120 Ω (option)
	Address	Default 247d, configurable

NAME Fields	Arbitrary address capable	0	No
	Industry group	0	Global
	Vehicle system	7Fh (127d)	Non specific
	Vehicle system instance	0	
	Function	FFh (255d)	Non specific
	Function instance	0	
	ECU instance	0	
	Manufacturer	145h (325d)	Manufacturer ID
	Identity number	0nnn	Serial number 21 bit

Parameter Group Numbers (PGN)	Configuration data	PGN EF00h	Proprietary-A (PDU1 peer-to-peer)
	Process data	PGN FFnnh	Proprietary-B (PDU2 broadcast); nn Group Extension (PS) configurable

Specifications	Excitation voltage	18 ... 36 V DC
	Excitation current	Typ. 20 mA for 24 V, max. 80 mA
	Measuring rate	1 kHz (asynchronous)
	Stability (temperature)	±50 x 10 ⁻⁶ / °C f.s.
	Repeatability	1 LSB
	Operating temperature	-40 ... +85 °C
	Protection	Reverse polarity, short circuit
	Dielectric strength	500 V (V AC, 50 Hz, 1 min.)
	EMC	EN 61326-1:2013

When using multiple magnets the distance between two magnets must be min. 70 mm to identify the single magnets definitely!

Signal wiring and connection see page 42.

Setup procedure



Warning notice

- Changing the parameters can cause a sudden step of the instantaneous value and can result in unexpected machine (re)actions!
- Precautions to prevent danger for man or machine are necessary!
- Execute parametrizing at standstill of the machine only!

Node-ID

The default Node-ID the sensor will claim on power up is user or factory configurable. The user can configure by "Commanded Address" service according to the J1939 standard or by Peer-to-Peer message as described below.

User configuration

User accessible parameters including node-ID may be configured by peer-to-peer proprietary A message PGN 0EF00h. The parameters are accessed by byte-index and read/write operations coded in the data frame. The slave will return the data frame including the acknowledge code. Parameter values will be effective immediately. On execution of "Store Parameters" the configuration is saved nonvolatile.

Peer-to-peer message (PGN 0x00EF00), send/receive format

PGN		8 Byte data frame							
PGN _{HIGH}	PGN _{LOW} (Node-ID)	Index	Rd/Wr	0	Ack	4-Byte Data			

Request: Control Unit → Sensor

→	0EFh	dd	i	0/1	0	0	LSB	MSB
---	------	----	---	-----	---	---	-----	----	----	-----

Response: Control Unit ← Sensor

←	0EFh	cc	i	0/1	0	a	LSB	MSB
---	------	----	---	-----	---	---	-----	----	----	-----

- a: Acknowledge codes:
 0: Acknowledge, 81: Read only parameter, 82: Range overflow,
 83: Range underflow, 84: Parameter does not exist
- dd: Sensor Node-ID (Default 0F7h, 247d)
- cc: Control-Unit Node-ID

Configuration examples

Example: Set Transmit Cycle to 10ms, Index 31, Node-ID 247d (F7h)

	PGN _{HIGH}	PGN _{LOW}	8 Byte data frame							
→	0EFh	0F7h	1Fh	01h	00	00	0Ah	00	00	00
←	0EFh	cc	1Fh	01h	00	00	0Ah	00	00	00

Example: Read Transmit Cycle value, Index 31

→	0EFh	0F7h	1Fh	00	00	00	00	00	00	00
←	0EFh	cc	1Fh	00	00	00	0Ah	00	00	00

Example: Store Parameters permanently, Index 28

→	0EFh	0F7h	1Ch	01h	00	00	65h	76h	61h	73h
←	0EFh	cc	1Ch	01h	00	00	65h	76h	61h	73h

Example: Reload factory defaults, Index 29

→	0EFh	0F7h	1Dh	01h	00	00	64h	61h	6Fh	6Ch
←	0EFh	cc	1Dh	01h	00	00	64h	61h	6Fh	6Ch

Example: Broadcast (PGN_{LOW} = 0FFh) - Reload factory defaults of all sensors, Index 29

→	0EFh	0FFh	1Dh	01h	00	00	64h	61h	6Fh	6Ch
←	0EFh	cc	1Dh	01h	00	00	64h	61h	6Fh	6Ch

Table of configurable bit rates (see next page, index 21)	Index 21	Bit rate
	0	1000 kBit/s
	1	800 kBit/s
	2	500 kBit/s
	3	250 kBit/s
	4	125 kBit/s
	5	50 kBit/s

Configurable parameters Linear Encoder Parameters - Standard Configuration

Parameter	Index [dec]	Default	Range / Selection	Unit	Read / Write
Control					
Node ID	20	247	128 ... 247		rd/wr ¹⁾
Baude rate	21	3 (250kB)	0 ... 5		rd/wr ²⁾
Termination resistor	22	0	-		rd ²⁾
Store parameters	28	-	"save" ³⁾		wr
Reload factory defaults	29	-	"load" ³⁾		wr ²⁾
Communication					
Transmit mode	30	0	0 timer 1 request 2 event		rd/wr
Transmit cycle	31	100	10 ... 65535	ms	rd/wr
PGN Group Extension	32	0	0 ... 255		rd/wr
Event mode hysteresis	38	1000	0 ... 10000	steps	rd/wr
Process data byte order	39	0	0 little / 1 big endian		rd/wr
Measurement					
Code sequence	70	0	0 CW 1 CCW		rd/wr
Number of position magnets	72	1	1 ... 4		rd/wr
Measuring step	73	50	1 ... 1000	µm	rd/wr
Preset	74	0	0 ... 10000	steps	rd/wr
Averaging Filter	77	1	1 ... 255		rd/wr
Identification					
SW Version	198	-	4 bytes	number	rd
Serial number	199	-	4 bytes	number	rd
Identity number	200	-	21 bit	number	rd

1) Change of Node ID by writing to index 20 is effective immediately and initiates Address Claiming

2) Effective on next power-up

3) „save“ MSB...LSB: 73h, 61h, 76h, 65h
„load“ MSB...LSB: 6Ch, 6Fh, 61h, 64h

Broadcast access by PGN_{LOW} = 0FFh addresses the specified index of all sensors.

Process data

Process data are transmitted by broadcast proprietary-B-Message PGN 0x00FFxx where the low byte is configurable. If the number of position magnets is configured to more than one magnet, position and velocity values are transmitted by a number of successive process data messages.

Byte order of process data message

B7	B6	B5	B4	B3	B2	B1	B0
Error	M_Index	Velocity		Position			
*)	1 ... 4	MSB	LSB	MSB			LSB

*) Error codes: 0 = no error
1,2 ... = error, number of missing magnets
081h, 082h ... = error, number of too many magnets detected

M_Index: Auto incrementing index for subsequent process data management in multimagnet configuration.

Signal wiring	Signal	Connector pin no.
	Shield	1
	Excitation +	2
	GND	3
	CAN-H	4
	CAN-L	5

View to sensor connector

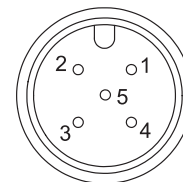

CAN bus wiring

Connect the device by a T-connector to the CAN trunk line. Total length of stubs should be minimized. Do not use single stub lines longer than 0.5 m. Connect terminating resistors 120 Ohm at both ends of the trunk line.

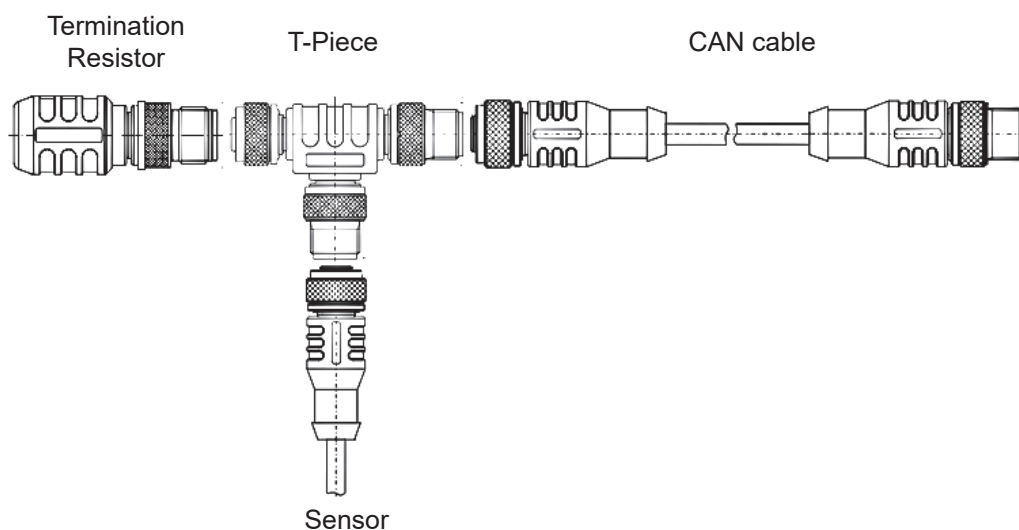

Connector cable for posichron® position sensors
M12 8 pin

The 8-lead shielded cable is supplied with a mating 8-pin 90° M12 connector at one end and 8 wires at the other end. Available lengths are 2, 5 and 10 m. Wire: cross sectional area 0.25 mm².

Order code:
KAB - XM - M12/8F/W - LITZE
 IP69K: **KAB - XM - M12/8F/W/69K - LITZE**
 Length in m

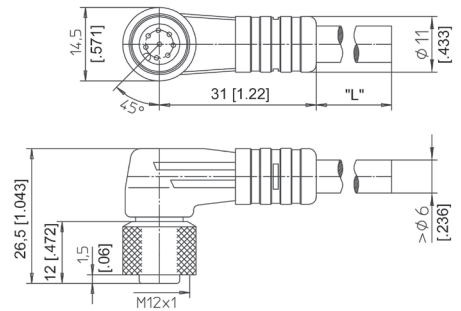

Connector cable for posichron® position sensors
M12 8 pin

The 8-lead shielded cable is supplied with a mating 8-pin M12 connector at one end and 8 wires at the other end. Available lengths are 2, 5 and 10 m. Wire: cross sectional area 0.25 mm².

Order code:
KAB - XM - M12/8F/G - LITZE
 IP69K: **KAB - XM - M12/8F/G/69K - LITZE**
 Length in m

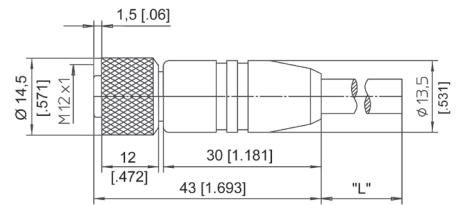

Connector cable wiring - M12, 8 pin	Connector pin / cable color							
	1	2	3	4	5	6	7	8
	White	Brown	Green	Yellow	Grey	Pink	Blue	Red

Connector cable wiring - M12, 4 pin	Connector pin / cable color			
	1	2	3	4
	Brown	White	Blue	Black

**Connector cable for
posichron®
position sensors
M8 4 pin**

The 4-lead shielded cable is supplied with a mating 4-pin 90° M8 connector at one end and 4 wires at the other end. Available lengths are 2, 5 and 10 m. Wire: cross sectional area 0.14 mm².

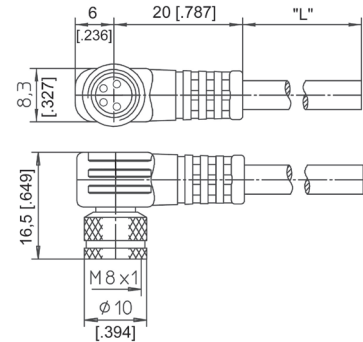

Order code:

KAB - XM - M8/4F/W - LITZE

IP69K: **KAB - XM - M8/4F/W/69K - LITZE**

Length in m

**Connector cable for
posichron®
position sensors
M8 4 pin**

The 4-lead shielded cable is supplied with a mating 4-pin M8 connector at one end and 4 wires at the other end. Available lengths are 2, 5 and 10 m. Wire: cross sectional area 0.14 mm².

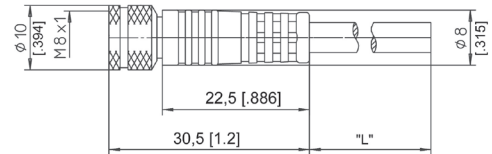

Order code:

KAB - XM - M8/4F/G - LITZE

IP69K: **KAB - XM - M8/4F/G/69K - LITZE**

Length in m

Connector cable wiring - M8, 4 pin	Connector pin / cable color			
	1	2	3	4
Brown	White	Blue	Black	

**Connector/bus cable
for posichron®
position sensors**
5 pin M12
CAN bus

The 5-lead shielded cable is supplied with a female 5-pin M12 connector at one end and a male 5-pin M12 connector at the other end. Available lengths are 0.3 m, 2 m, 5 m and 10 m.

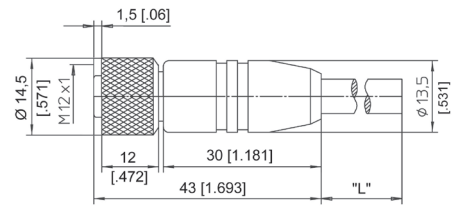

Order code:

KAB - XM - M12/5F/G - M12/5M/G - CAN

IP69K: **KAB - XM - M12/5F/G/69K - M12/5M/G/69K - CAN**

Length in m

T-piece for bus cable
5 pin M12
CAN bus

Order code:

KAB - TCONN - M12/5M - 2M12/5F - CAN

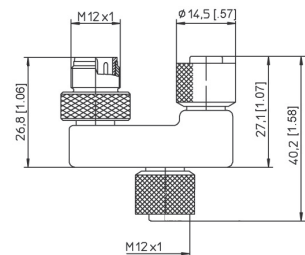

**Terminating
resistance**
5 pin M12
CAN bus

Order code:

KAB - RTERM - M12/5M/G - CAN



PCMAG5

Magnet guidance distance

Maximum Misalignment		± 12 mm			
Profile orientation		flat		upright	
Linearity		L02	L10	L02	L10
Profile	Magnet	Air Gap [mm]			
PCQA22 / PCQA24	PCMAG5	1 - 2	1 - 4		
	PCMAG5-6	2 - 4	2 - 6		
	PCMAG5-20	4 - 8	4 - 10		
	PCMAG5-25	6 - 8	4 - 14		
PCPF23 / PCFP24	PCMAG5	1 - 3	1 - 5	1 - 1	1 - 2
	PCMAG5-6	3 - 5	3 - 7	1 - 2	1 - 4
	PCMAG5-20	5 - 9	5 - 11	2 - 6	2 - 8
	PCMAG5-25	7 - 9	5 - 15	4 - 6	2 - 12
PCFP25	PCMAG5	3 - 5	3 - 7	2 - 4	2 - 6
	PCMAG5-6	5 - 7	5 - 9	4 - 6	4 - 8
	PCMAG5-20	7 - 11	7 - 13	6 - 10	6 - 12
	PCMAG5-25	9 - 11	7 - 17	8 - 10	6 - 16
PCRP21	PCMAG5	1 - 4	1 - 6		
	PCMAG5-6	4 - 6	4 - 8		
	PCMAG5-20	6 - 10	6 - 12		
	PCMAG5-25	8 - 10	6 - 16		
PCRP32	PCMAG5	1 - 3	1 - 5		
	PCMAG5-6	3 - 5	3 - 7		
	PCMAG5-20	5 - 9	5 - 11		
	PCMAG5-25	7 - 9	5 - 15		
PCST24 / PCST25 / PCST27	PCMAG5	1 - 4	1 - 6		
	PCMAG5-6	4 - 6	4 - 8		
	PCMAG5-20	6 - 10	6 - 12		
	PCMAG5-25	8 - 10	6 - 16		

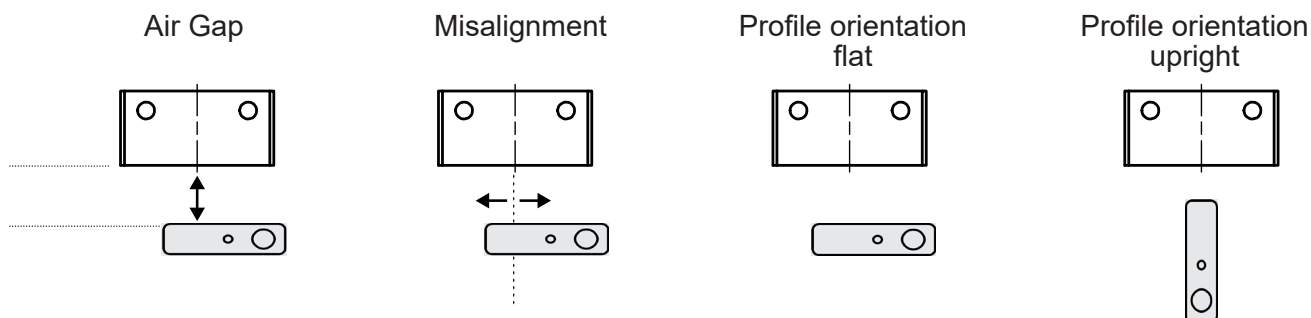

PCMAG5

Magnet guidance distance

Maximum Misalignment		± 6 mm			
Profile orientation		flat		upright	
Linearity		L02	L10	L02	L10
Profile	Magnet	Air Gap [mm]			
PCQA22 / PCQA24	PCMAG5	1 - 4	1 - 6		
	PCMAG5-6	2 - 6	2 - 8		
	PCMAG5-20	4 - 10	4 - 12		
	PCMAG5-25	6 - 10	4 - 16		
PCPF23 / PCFP24	PCMAG5	1 - 5	1 - 7	1 - 2	1 - 4
	PCMAG5-6	3 - 7	3 - 9	1 - 4	1 - 6
	PCMAG5-20	5 - 11	5 - 13	2 - 8	2 - 10
	PCMAG5-25	7 - 11	5 - 17	4 - 8	2 - 14
PCFP25	PCMAG5	3 - 7	3 - 9	2 - 6	2 - 8
	PCMAG5-6	5 - 9	5 - 11	4 - 8	4 - 10
	PCMAG5-20	7 - 13	7 - 15	6 - 12	6 - 14
	PCMAG5-25	9 - 13	7 - 19	8 - 12	6 - 18
PCRP21	PCMAG5	1 - 6	1 - 8		
	PCMAG5-6	4 - 8	4 - 10		
	PCMAG5-20	6 - 12	6 - 14		
	PCMAG5-25	8 - 12	6 - 18		
PCRP32	PCMAG5	1 - 5	1 - 7		
	PCMAG5-6	3 - 7	3 - 9		
	PCMAG5-20	5 - 11	5 - 13		
	PCMAG5-25	7 - 11	5 - 17		
PCST24 / PCST25 / PCST27	PCMAG5	1 - 6	1 - 8		
	PCMAG5-6	4 - 8	4 - 10		
	PCMAG5-20	6 - 12	6 - 14		
	PCMAG5-25	8 - 12	6 - 18		

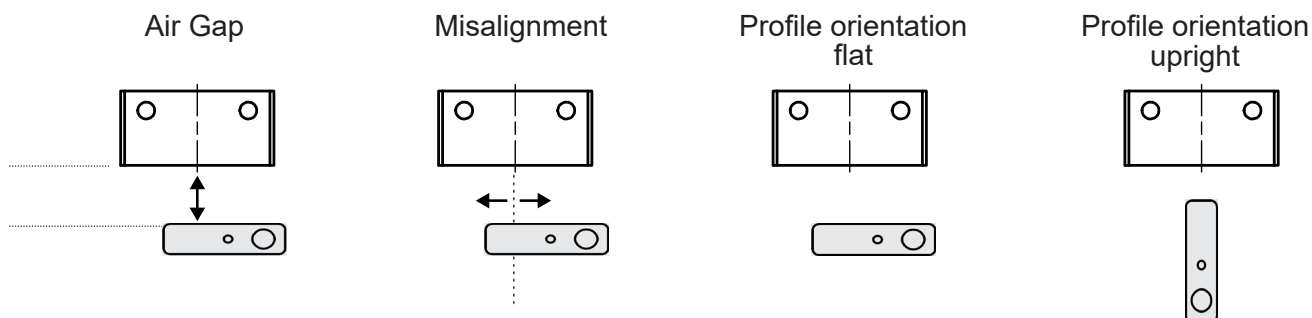

PCMAG5
Standard
magnet

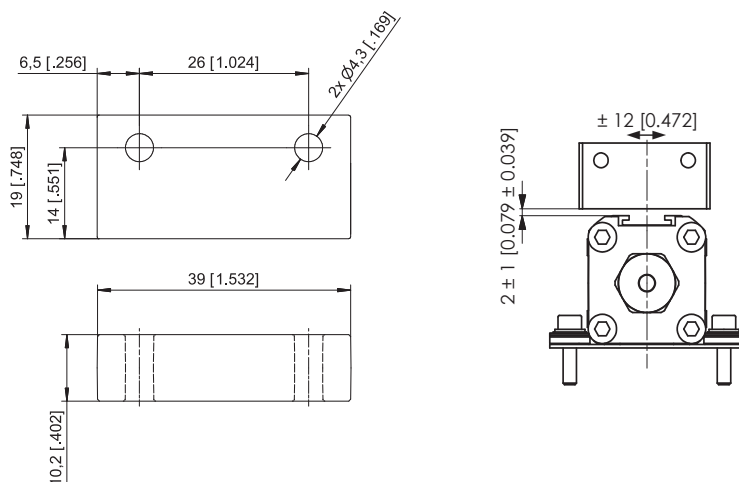

PCMAG3
Guided magnet
slider for PCQA
with internal
position magnet

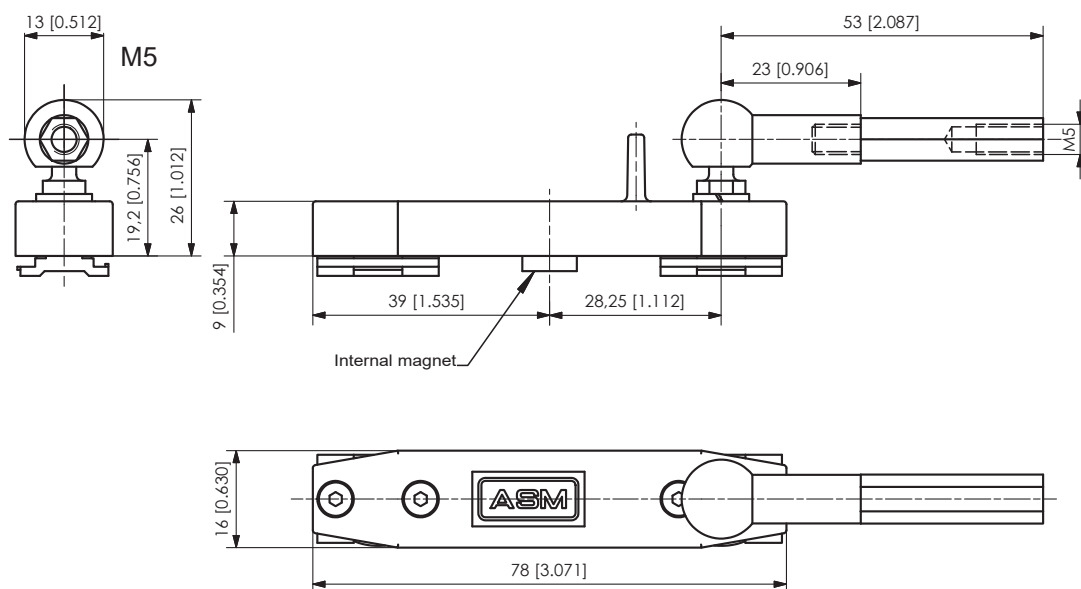

Dimensions in mm [inch]

Dimensions informative only.

For guaranteed dimensions consult factory.

PCRPMAG6

Guided magnet
slider for PCRP21 with
internal position magnet

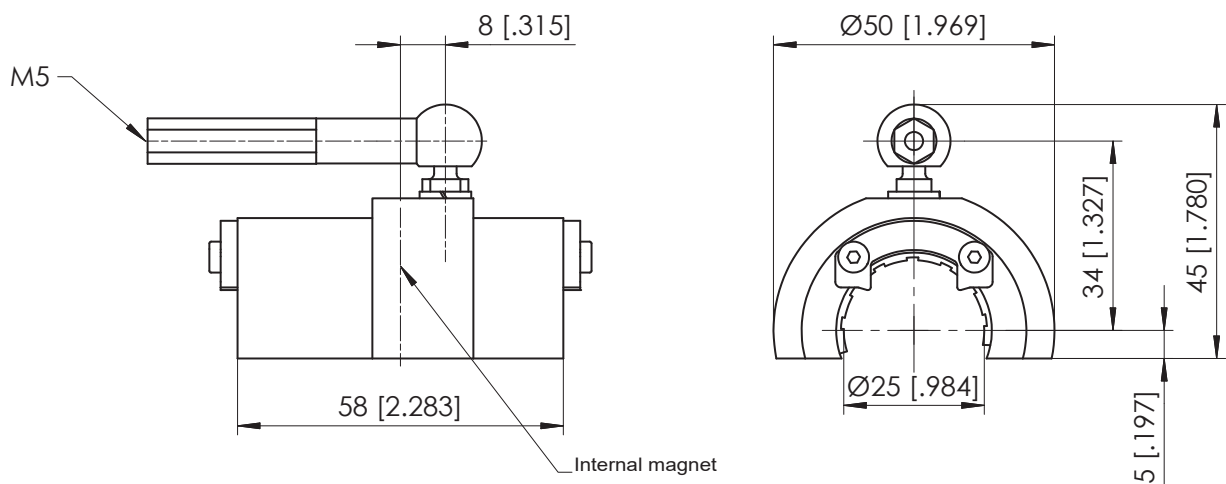

Dimensions in mm [inch]

Dimensions informative only.

For guaranteed dimensions consult factory.

PCSTMAG1

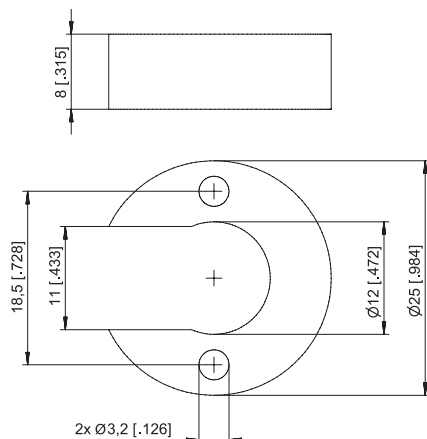

PCSTMAG2 (standard)

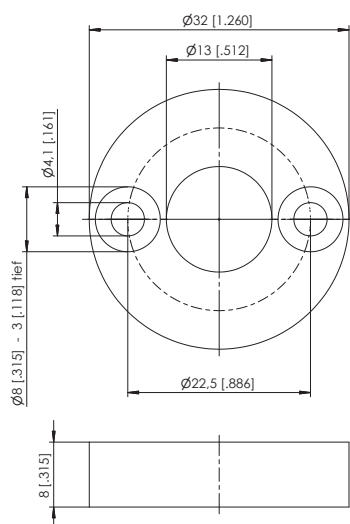

PCSTMAG2-BFS1

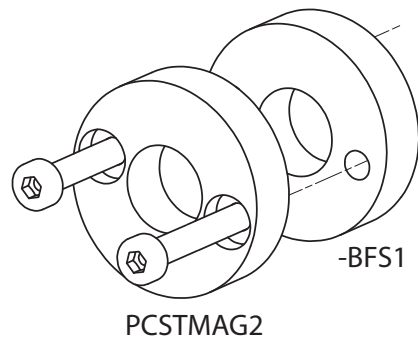

PCSTMAG5

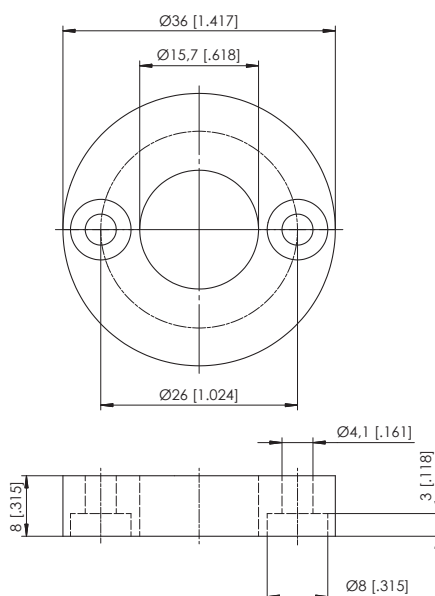

Dimensions in mm [inch]

Dimensions informative only.
For guaranteed dimensions consult factory.

PCSTMAG2-MH1

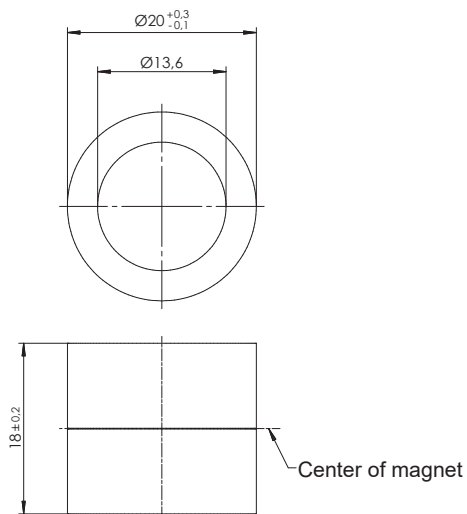

PCSTMAG2-MH2

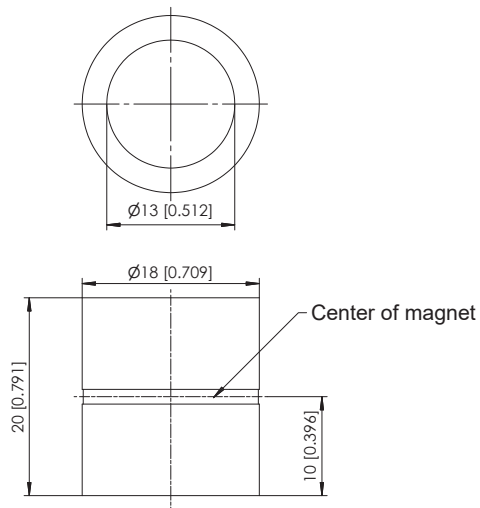

PCSTMAG2-MH3

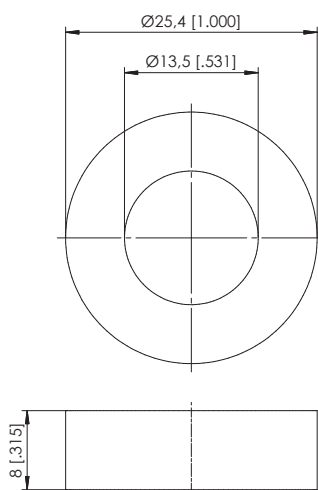

Dimensions in mm [inch]

Dimensions informative only.

For guaranteed dimensions consult factory.

PCSTMAG2-G1

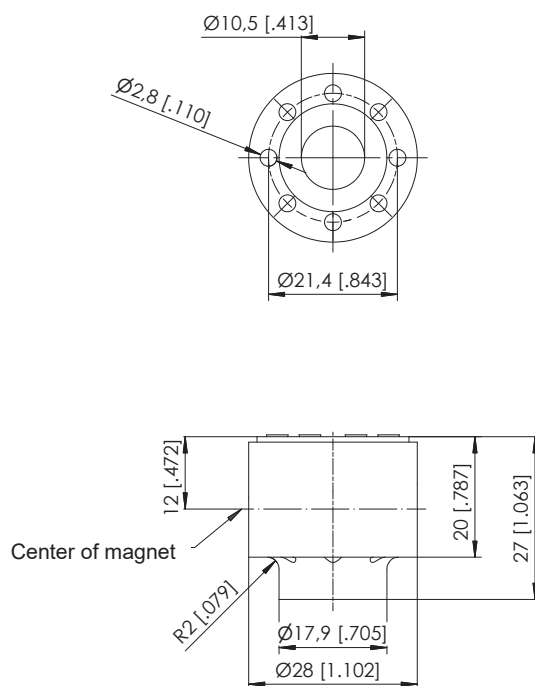

PCSTMAG2-G2

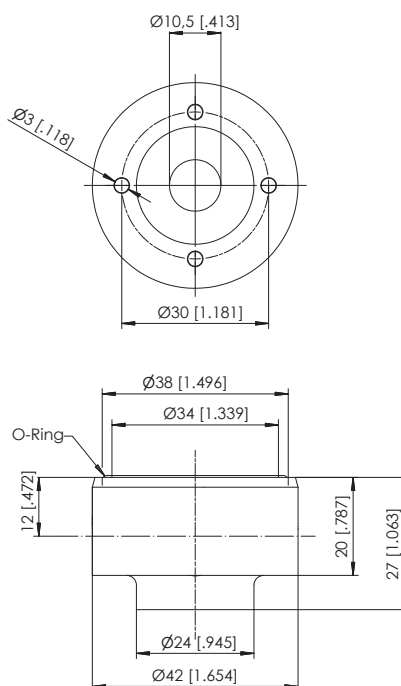

Dimensions in mm [inch]

Dimensions informative only.

For guaranteed dimensions consult factory.

PCSTMAG7

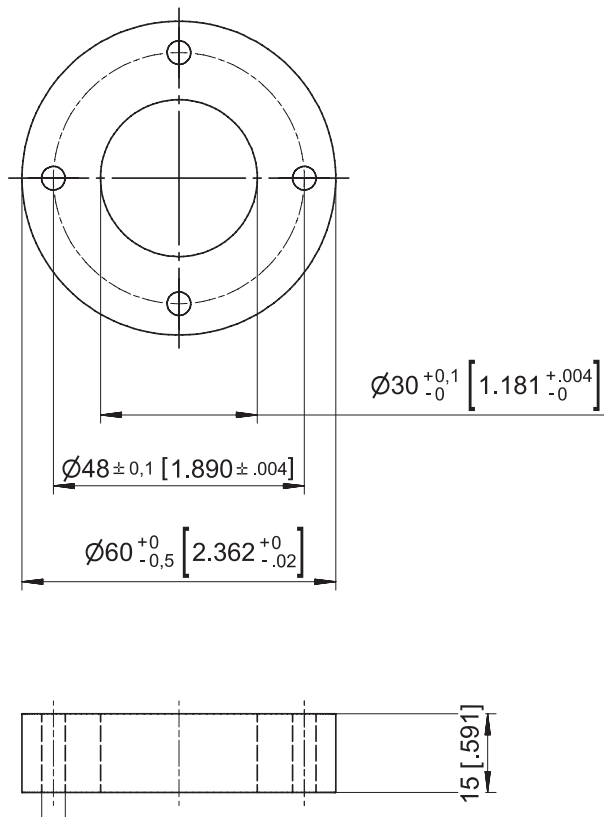

PCSTMAG4

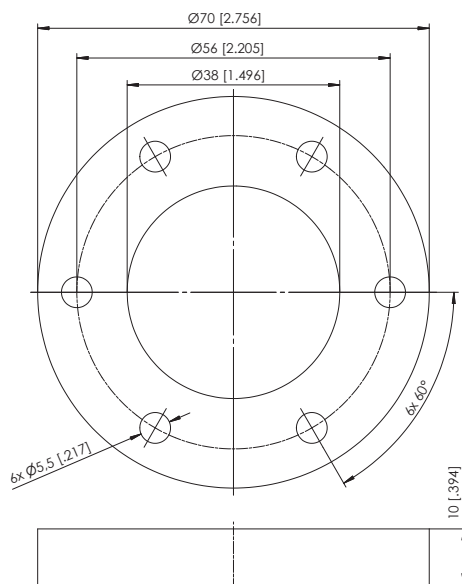

Dimensions in mm [inch]

Dimensions informative only.

For guaranteed dimensions consult factory.

PCSTMAG3

(float, continuous pressure up to 9 bar, for media with a specific gravity of $\geq 0,75 \text{ g/cm}^3$)

Material: 1.4404

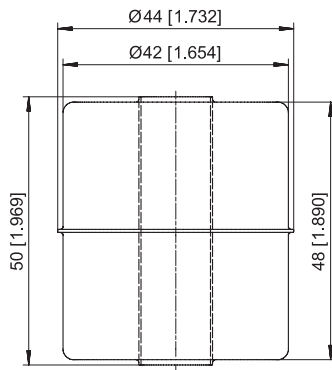

Note: Dependent on the design the available measurement range is reduced of 25 mm on both ends!

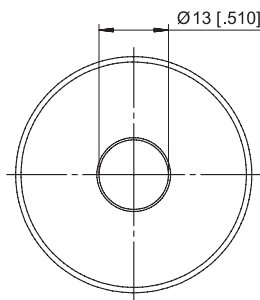

PCSTMAG6

(float, continuous pressure up to 30 bar, for media with a specific gravity of $\geq 0,7 \text{ g/cm}^3$)

Material: 1.4571

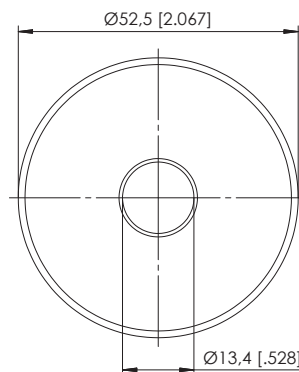

Note: Dependent on the design the available measurement range is reduced of 25 mm on both ends!

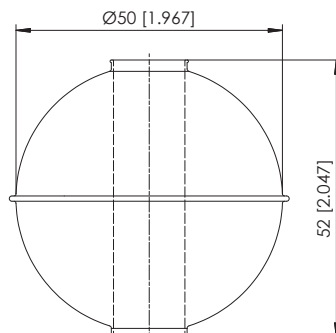

Dimensions in mm [inch]

Dimensions informative only.
For guaranteed dimensions consult factory.

Models PCFP23, PCFP24, PCFP25,
PCST24, PCST25, PCST26, PCST27,
PCRP21, PCRP32,
PCQA22, PCQA24

Outputs

U1	Voltage output	0 ... 10 V
U2	Voltage output	0.5 ... 10 V
U3	Voltage output	0 ... 5 V
U8	Voltage output	0.5 ... 4.5 V
I1	Current output	4 ... 20 mA
I2	Current output	0 ... 20 mA

Characteristics	Probability of failure	0,6 x 10 ⁻⁶ /h
	Life period MTTF	190 years
	Working Life	10 years
Standards	Failure rate of electronic components (Siemens)	SN 29500



perfect in sensors.

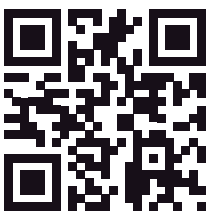

www.asm-sensor.com

**ASM Automation Sensorik
Messtechnik GmbH**
Am Bleichbach 18 - 24
85452 Moosinning
Germany
Tel. +49 8123 986-0
Fax +49 8123 986-500
info@asm-sensor.com

ASM Sensors, Inc.
650 W. Grand Ave., Unit 205
Elmhurst, IL 60126
USA
Tel. +1 630 832-3202
Fax +1 630 832-3204
info@asmsensors.com

ASM Sales Office UK
Tanyard House, High Street
Measham, Derbs DE12 7HR
United Kingdom
Tel. +44 845 1222-123
Fax +44 845 1222-124
info@asm-sensor.com