

EXS DRY SCREW VACUUM PUMP AND COMBINATIONS

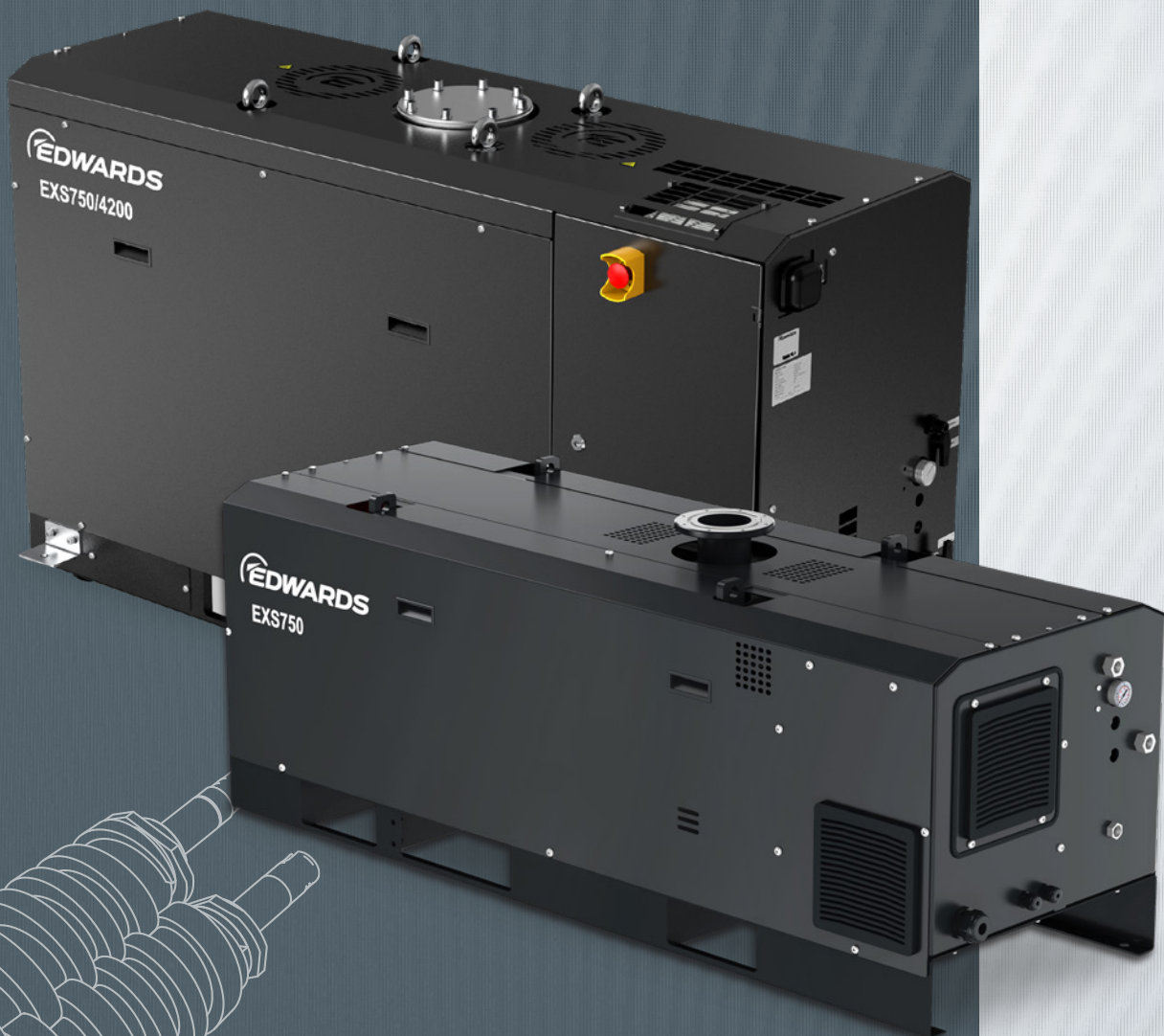

EXS DRY SCREW VACUUM PUMPS AND COMBINATIONS

Our EXS dry screw vacuum pumps take our industry proven screw vacuum technology to the next level. Based around the same technology that we use in our GXS pumps, the EXS has been designed to bring the advantages of our market leading technology in a package that focuses on simplicity and robustness. With more performance, simple control philosophy and low maintenance costs, the EXS will deliver reliable performance for many years to come. Our EXS series of dry screw vacuum pumps are available in EXS450, EXS750 and EXS750/4200 models.



◀ EXS450



◀ EXS750



◀ EXS750/4200

EDWARDS THE PARTNER OF CHOICE

Edwards is a world leader in the design, technology and manufacture of vacuum pumps for industrial applications with over 100 years' history.

We believe in delivering results that bring value to our customers by using our breadth of industry experience to identify and apply solutions. Using the most innovative and up-to-date modelling techniques, we can optimise the pumping configuration for customers to provide a system design giving the maximum performance in the most reliable and cost-effective way.



PROVEN – Based on existing GXS technology

- **Huge install base:** on hundreds of applications
- **Optimised design:** enables enhanced performance



ECONOMICAL – Affordable capital investment and low cost of ownership

- **Substantial savings:** low utilities and energy usage costs
- **Save on space:** small footprint



ENVIRONMENTAL – Smooth, quiet running with low power and utilities consumption

- **Small carbon footprint:** low power and utilities usage
- **Easy on environment:** no contaminated or dirty disposable oil



FAST – Increased pumping speed at high pressures and low ultimate performance

- **Increased productivity:** faster processing and pump down times
- **Low ultimate pressure** $<1 \times 10^{-2}$ for dry screw vacuum pumps and $<1 \times 10^{-3}$ for pump plus booster combination



ROBUST – Reliable operation even in harsh industrial applications

- **Low maintenance cost:** no unplanned down times
- **Increased productivity:** longer intervals between service



SYSTEMISED – Simplified design and improved performance

- Combination with GXB4200 roots booster
- Addition of blow-off valves for improved roughing speed

FEATURES AND INNOVATIVE SCREW TECHNOLOGY

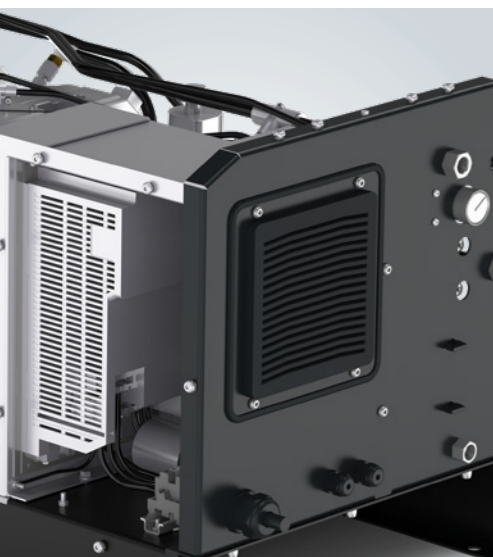

Simple electrical strategy

- In-built, off-shelf inverter for simple connection and communication
- Protection sensors fitted, electrical cabinet design for reliability and safety
- Basic control philosophy for ease of installation and operation

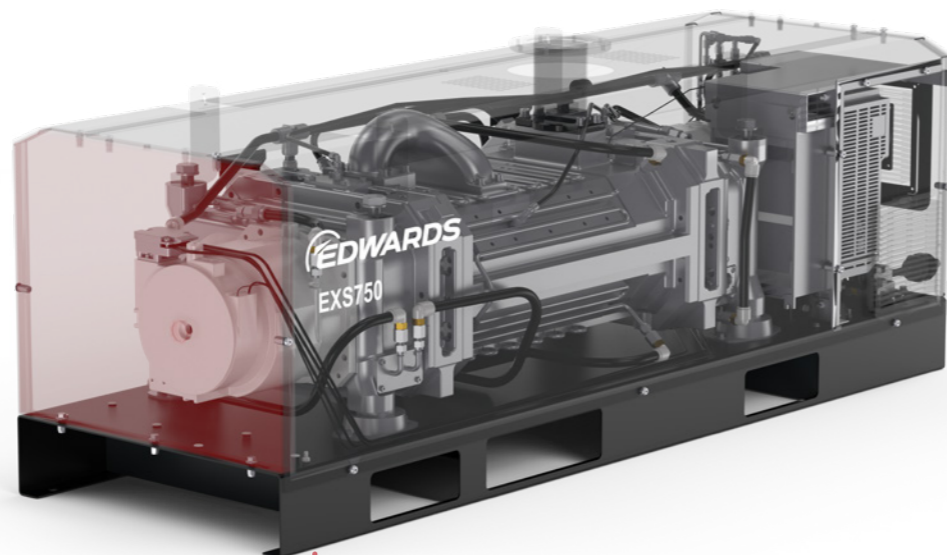

Robust design features

- Reliable constant flow cooling system
- Dependable new gas system with manual gas ballast control
- Sleek sheet metal protective enclosure
- Patented tapered variable pitch Quinby profile screw

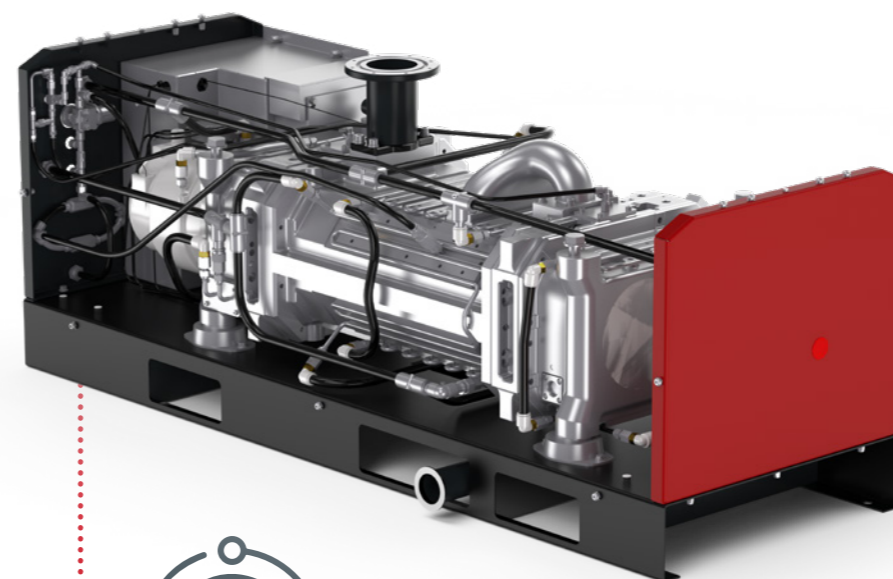

Advanced core technology

- Non-contacting long-life seals with integral oil blocking labyrinth seal provides highly effective sealing
- Combined with a six litre per minute seal purge the gearbox is protected from contamination and the vacuum space is kept free of oil
- Industry proven on 100s of applications
- Uses advanced quality bearings and special purpose oil with low vapour pressure for application compatibility and improved service life
- Non-cantilever design provides secure rotor support for extremely low vibration and superior starting reliability, especially on harsh processes
- Superior liquid and powder handling thanks to a sealing solution that is industry proven in 100s of applications



Compact design

- Deliver the benefits of a simple and economical installation

APPLICATIONS

The EXS pump is suitable for a range of applications in various industries including:

Metallurgy

- Vacuum brazing
- E-beam welding
- Nitro carburising
- Low pressure nitriding
- Low pressure carburising
- Carbon vapour impregnation
- Sintering
- Metal injection moulding
- Precision investment casting
- Vacuum arc refining
- Steel degassing



Plasma processes

- Plasma welding
- Plasma nitriding

Vacuum chamber evacuation

- Space simulation chambers
- Gas recovery/circulation
- Load lock chambers



LED manufacture



Solar

- Silicon crystal-pulling
- PV lamination



Coating

- Roll web coating
- Hard coating (CVD/DLC)
- Surface activation
- Plasma spray
- Glass coating

TECHNICAL SPECIFICATIONS

Specification	Unit	EXS450	EXS750	EXS750/4200
Ultimate Vacuum	Mbar (Torr)	<math><1 \times 10^{-2}</math> (<math><8 \times 10^{-3}</math>)		<math><1 \times 10^{-3}</math> (<math><8 \times 10^{-4}</math>)
Peak Pumping Speed	m ³ /hr (cfm)	450 (265)	740 (435)	3450 (2032)
Ultimate Power	Kw (hp)	6 (8)	10.5 (14)	12 (16)
Full Load Power		11 (15)	22 (30)	24 (32)
Maximum Rotor Speed	Rev/min	6600		
Inlet/Outlet Flange		ISO100/NW50		ISO160/NW50
Dimensions (mm)	LxWxH mm (in)	1265 x 567 x 642 (49.8 x 22.3 x 25.3)	1650 x 567 x 642 (65 x 22.3 x 25.3)	1650 x 567 x 996 (65 x 22.3 x 39.2)
Connection		G3/8" female threads		
Cooling Flow (Always On)	l/min (gal/min)	10 (2.6)	12 (3.2)	15 (4)
Maximum Supply Pressure	barg (psig)	6.9 (100)		
Temperature	°C (°F)	5 to 40 (41 to 104)		
Connection		G1/2" female threads		
Pressure	barg (psig)	2.5 - 6.9 (36 - 100)		
Shaft Seal Flow (Always on)	l/min (gal/min)	12 (3.1)		
Gas Ballast Flow (Manual Adj.)	l/min	1 - 130 (0.2 - 34.3)		
Ambient Temperature Range	°C (°F)	5 to 40 (41 to 104)		
Noise Level with Silencer	dB(A)	<64	<70	
Maximum Exhaust Back Pressure	bar.a (psig)	1.2 (2.9)		

ORDERING INFORMATION

Part number	Pump description	High voltage	Low voltage	Side exhaust	Rear exhaust	Caster
A41840900	EXS450 HV MD SI	✓		✓		
A41840905	EXS450 LV MD RE CA		✓		✓	✓
A41840904	EXS450 HV MD RE CA	✓			✓	✓
A41870900	EXS750 HV MD SI	✓		✓		
A41870904	EXS750 HV MD RE CA	✓			✓	✓
A41870910	EXS750/4200 HV RE CA	✓			✓	✓

PERFORMANCE CURVES

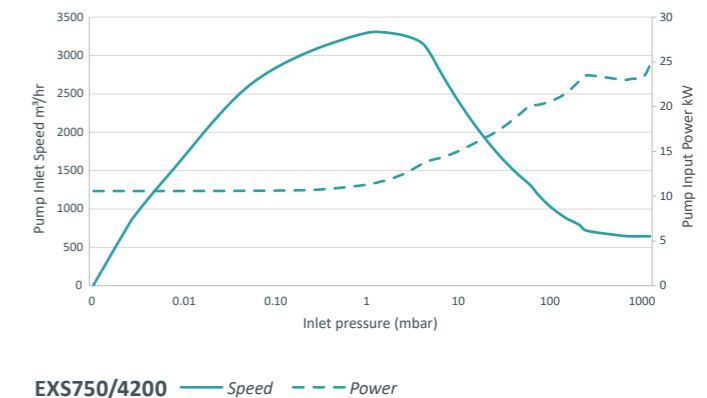
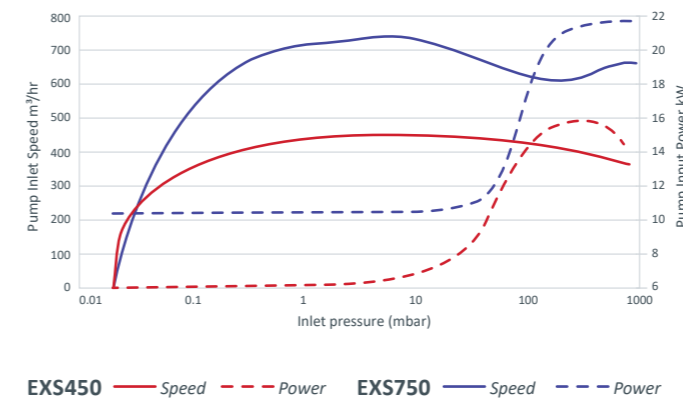

DIMENSIONS - EXS450

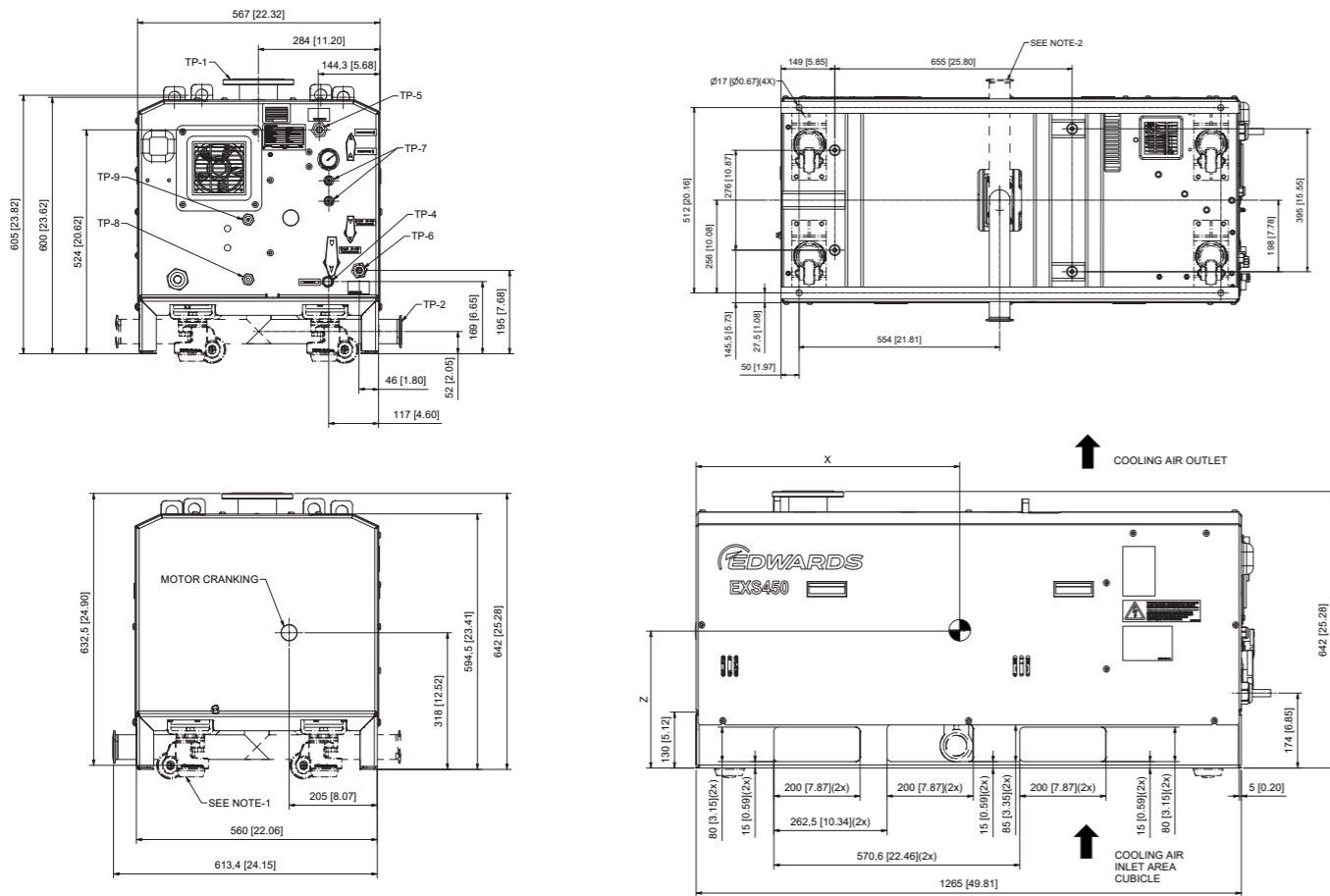

Note:

1. Available for side exhaust and rear exhaust
2. Caster is standard fitted for rear exhaust version while optional for Side exhaust version
3. Side exhaust outlet can be installed either side as per customer preference

EXS450 - REAR EXHAUST

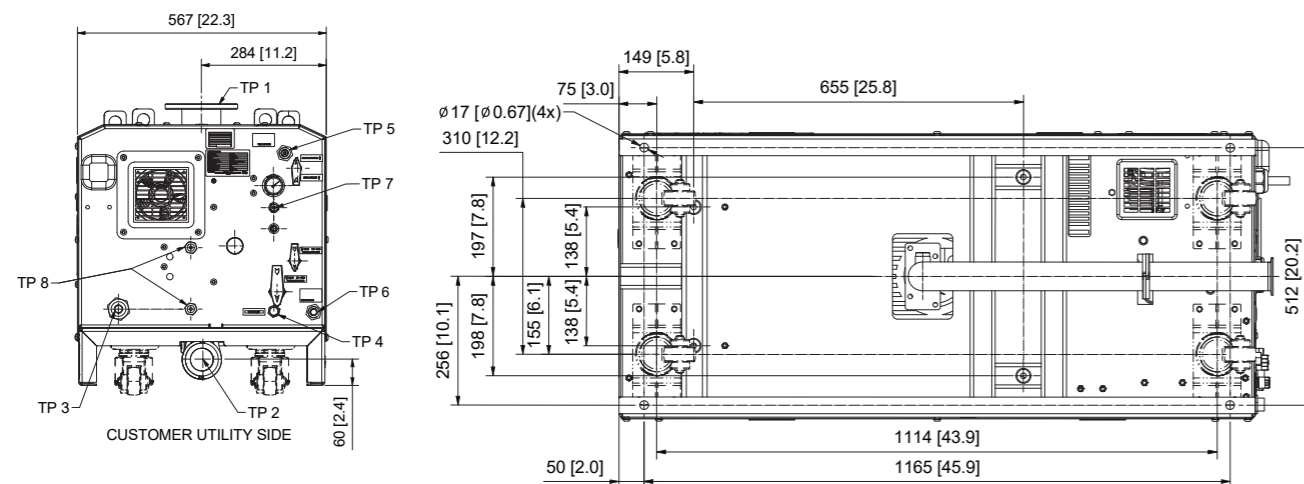

DIMENSIONS - EXS750

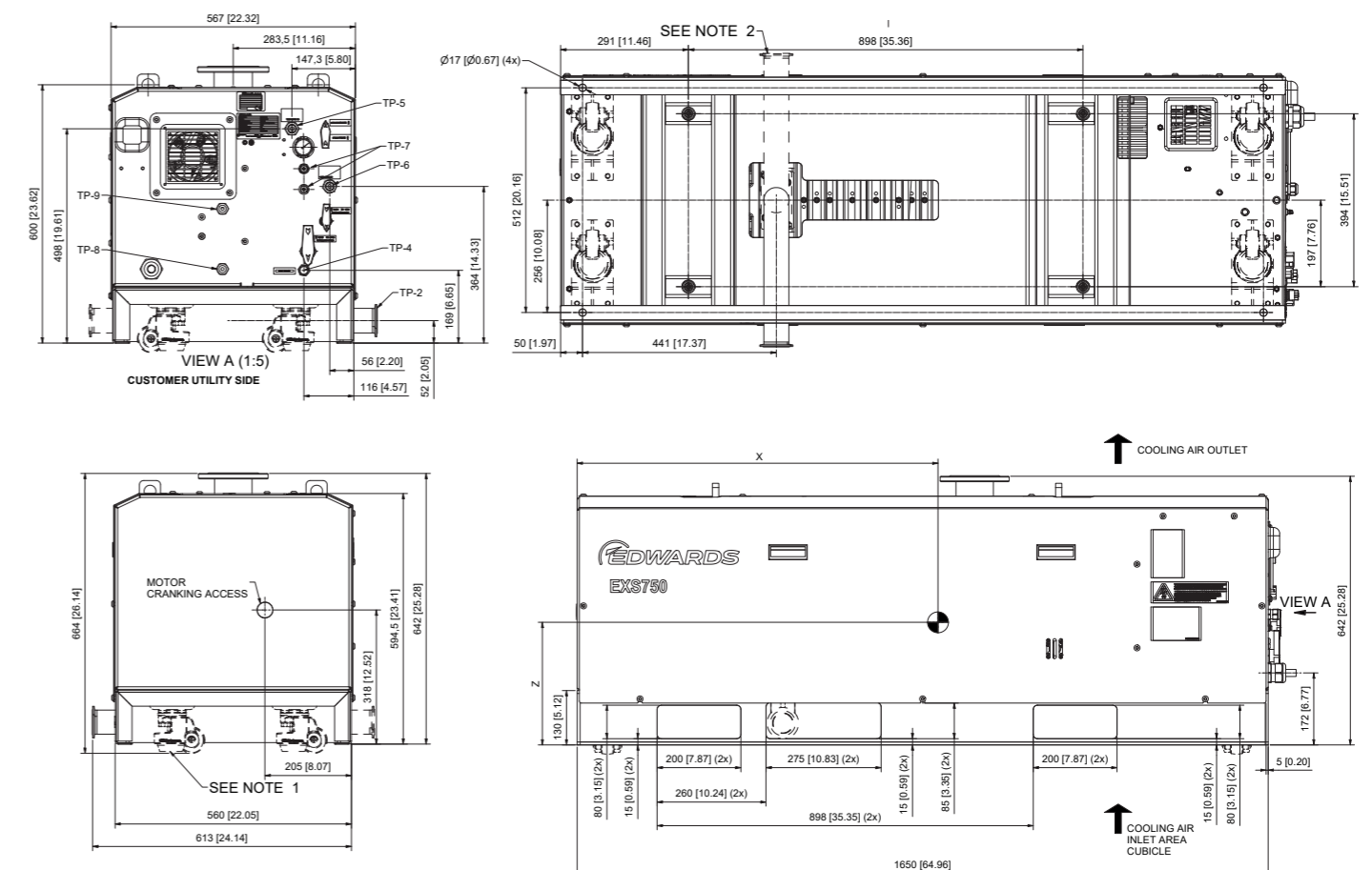

Note:

1. Available for side exhaust and rear exhaust
2. Caster is standard fitted for rear exhaust version while optional for Side exhaust version
3. Side exhaust outlet can be installed either side as per customer preference

EXS750 - REAR EXHAUST

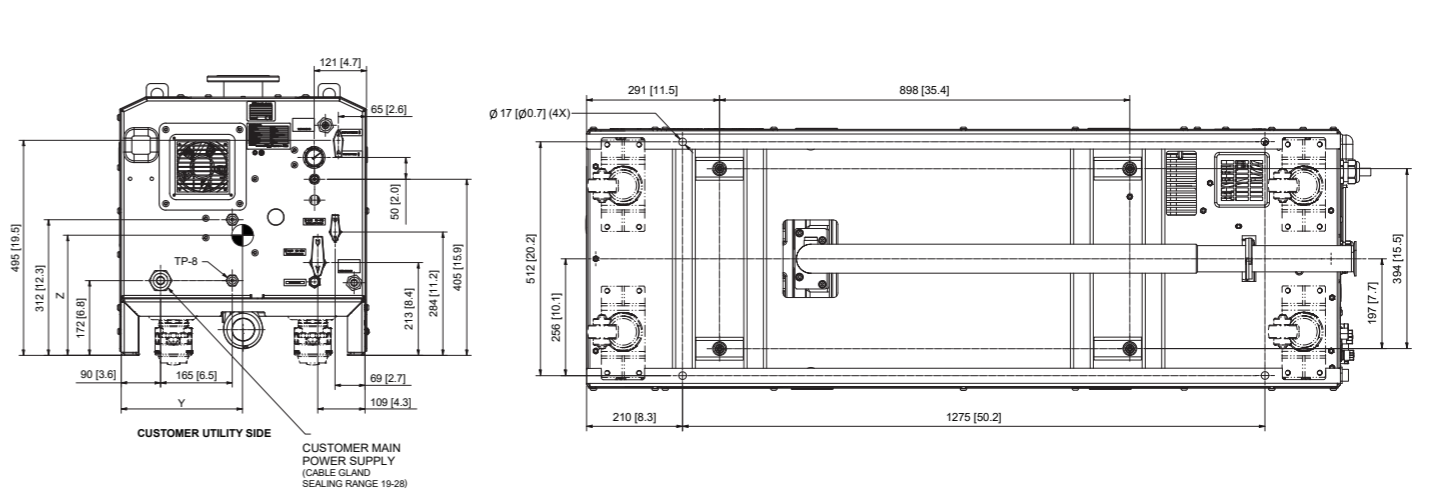

DIMENSIONS - EXS750/4200

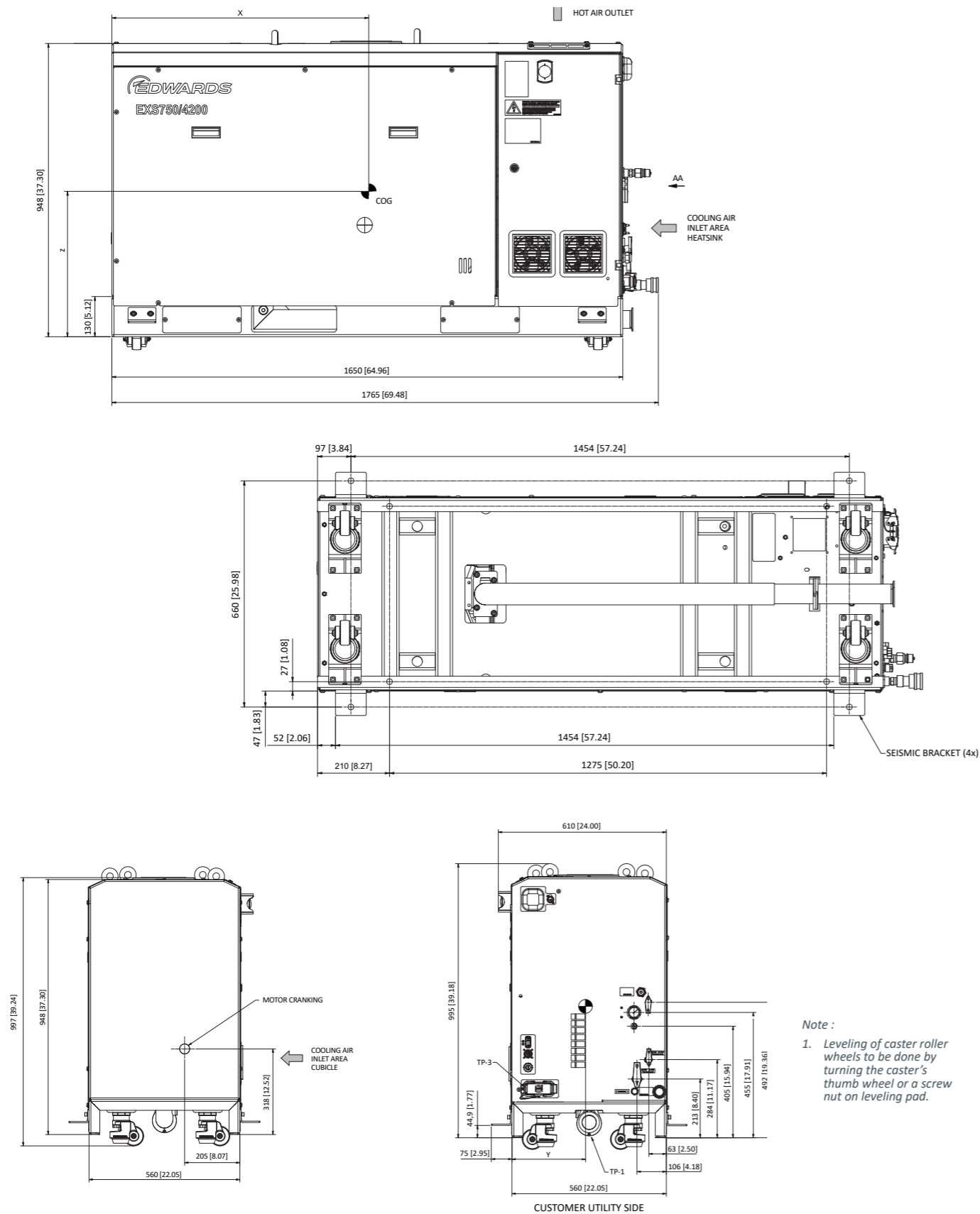

ACCESSORIES AND SYSTEMISATION

There are a range of standard accessories available with the EXS to suit a variety of applications. All accessories can be fully integrated with EXS to provide an efficient and safe system.

Accessories

The accessories have been especially designed to match the pumping capacities of the EXS range and optimise performance.

Part number	Description
M58810141	Cleanable Silencer NW50
M58810143	Cleanable Silencer NW50 Bottom Drain
A50790000	Exhaust Check valve kit NW50
M58810148	EH2600 & EH4200 Support kit for EXS750
M58810150	EH2600 & EH4200 Support kit for EXS450
M58810146	DP Clean Solvent Flush Kit
M58810147	Profibus Module
M58810145	Inlet Valve ISO100 kit
M58810144	Purge Free Kit
M58810149	Castor Kit
3002615139	Quick connector 1/2" for water cooling



In addition to these standard accessories, full customer specific systems are also available on request.

SERVICE AND SUPPORT

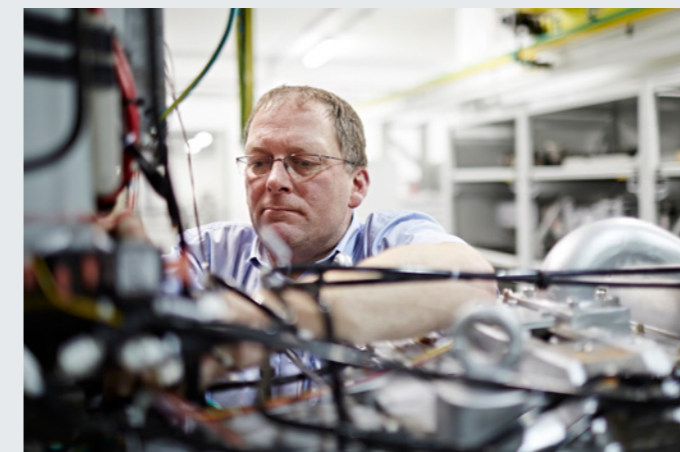

To ensure your EXS Dry Screw vacuum pump maintains optimal performance and reliability, we offer a wide range of service solutions, tailored to meet your needs. From Field Service intervention, Managed Maintenance agreements and Overhaul service in our Service Technology Centres (STC), we will take care of your pump to ensure that it continues to deliver clean, consistent, efficient performance, with lower running costs and optimum total cost of ownership for its operating life.

Selecting original spare parts, maintenance kits and oil means that every critical part performs as it was intended. Our services engineers only fit 100% genuine parts to ensure you receive the best result from each service.



Publication Number: 3602 117 1 01
© Edwards Limited 12.2022. All rights reserved.
Edwards and the Edwards logo are trademarks of
Edwards Limited.

Whilst we make every effort to ensure that we
accurately describe our products and services,
we give no guarantee as to the accuracy or
completeness of any information provided in
this brochure.

Edwards Ltd., registered in England and Wales
No. 6124750, registered office: Innovation Drive,
Burgess Hill, West Sussex, RH15 9TW, UK.