

INSTRUCTIONS

SPAZIO

TROUBLE 3 WIRE TRACK SPOT

8916.10.30 8916.10.31

Please read the instructions before commencing installation and retain for future reference.

SPECIFICATIONS:

- **Fitting:** Extruded aluminum housing with 10cm stem
- **Lamp types:** 10W /
- **Protection against electric shock:** CLASS I. Requires earth connection.
- **Ingress Protection:** IP20. Protection against the entry of solid bodies greater than 12mm
- **Driver:** Not applicable
- **Quality/Corrosive rating:** Suitable for commercial and domestic indoor applications.
- **Ambient temperature range:** -8°C to +55°C.

INSTALLATION INSTRUCTIONS:



Electrical products can cause death, injury or damage to property. Installation of this product must be carried out by a qualified electrician, in accordance with SANS 10142.

On completion of installation, ensure that the Certificate of Compliance is updated.



CAUTION: Risk of electric shock

Ensure mains supply is switched off.

- Rotate the housing and remove it from the lamp holder (Fig.1)
- Insert the lamp (Fig. 2)
- Re-attach the housing to the lamp holder (Fig.3)
- Attach the track lamp to the track line and lock in place (Fig. 4)
- Switch main supply back on.

WARNING:

- Ensure all items and screws are secure and fitted correctly.

TROUBLE 3 WIRE TRACK SPOT

Fig.1

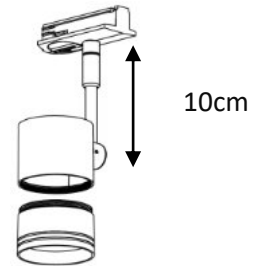

Fig.2



Fig.3



Fig.4

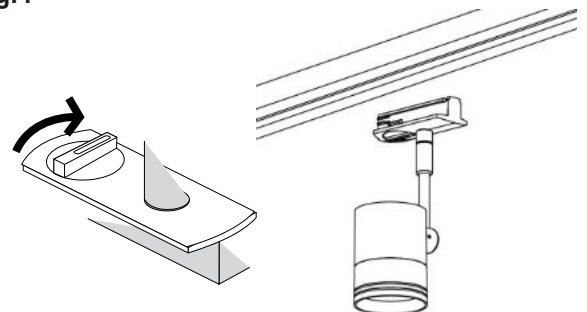

Spazio Lighting (Pty) LTD.

JOHANNESBURG OFFICE: 52 Andries Street | Wynberg/Sandton

CAPE TOWN OFFICE: 36 Milner Street | Paarden Eiland

DURBAN OFFICE : 31 Solstice Road | Umhlanga Ridge

011 555 5555 (Central Switchboard) | info@spazio.co.za