

INSTRUCTIONS



SILK PENDANT

8651.1.500 / 8651.1.750

8651.2.200 / 8651.2.300

8651.3.320 / 8651.3.400 / 8651.3.500

Please read the instructions before commencing installation and retain for future reference.

SPECIFICATIONS:

- **Fitting:** Metal base and frame with polymer resin shade
- **Lamp types:** Max. 60W / E27
- **Protection against electric shock:** CLASS I. Requires earth connection.
- **Ingress Protection:** IP20.
- **Quality/Corrosive rating:** Suitable for indoor commercial and residential applications.
- **Ambient temperature range:** -8°C to +55°C.

INSTALLATION INSTRUCTIONS:

⚠ Electrical products can cause death, injury or damage to property. Installation of this product must be carried out by a qualified electrician, in accordance with SANS 10142. On completion of installation, ensure that the Certificate of Compliance is updated.

Ensure main supply is switched off.

- Mount the two expansion anchors (supplied) on the ceiling. (Fig. 1)
- Mount the ceiling bracket to the anchors with the screws provided. (Fig. 2)
- Connect the fitting to its electrical source using the terminal block provided. (Fig. 3)
Brown (Live) - to Brown or Red
Blue (Neutral) - to Blue or Black
Green/Yellow (Earth) - to Green/Yellow or Copper.
- Fix the fitting base to the ceiling bracket. (Fig. 4)
- Adjust the length of suspension cable as needed. (Fig. 5)
- Install the lamp. (Fig. 6)

Switch main supply back on and test the fitting.

WARNING:

- Ensure all items and screws are secure and fitted correctly.

SILK PENDANT

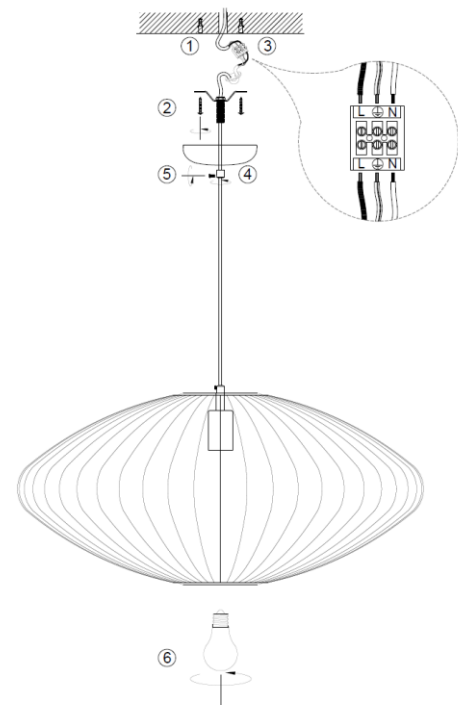
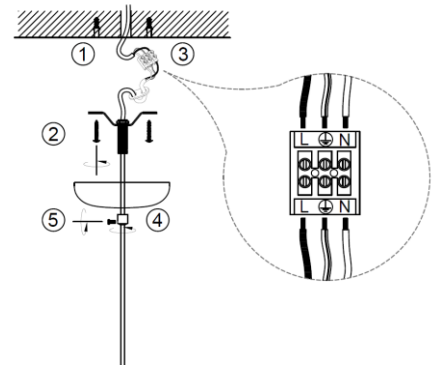

Spazio Lighting (Pty) LTD.

JOHANNESBURG OFFICE: 52 Andries Street | Wynberg/Sandton

CAPETOWN OFFICE: 36 Milner Road | Paarden Eiland

DURBAN OFFICE : 31 Solstice Road | Umhlanga Ridge

011 555 5555 (Central Switchboard) | info@spazio.co.za