

INSTRUCTIONS

SOHO AND BELTA PENDANT



8606.42 8606.51

8607.42 8607.51

Please read the instructions before commencing installation and retain for future reference.

SPECIFICATIONS:

- **Fitting:** Aluminum shade and base
- **Lamp types:** E27 MAX 60W 230V
- **Protection against electric shock:** CLASS I. Requires earth connection.
- **Ingress Protection:** IP20. Protection against the entry of solid bodies with dimensions > 12mm
- **Quality/Corrosive rating:** Suitable for indoor commercial and residential applications.

INSTALLATION INSTRUCTIONS:

⚠ Electrical products can cause death, injury or damage to property. Installation of this product must be carried out by a qualified electrician, in accordance with SANS 10142. On completion of installation, ensure that the Certificate of Compliance is updated.



CAUTION: Risk of electric shock

PLEASE NOTE: The light source contained on this luminaire shall only be replaced by the manufacturer or the service agent or a similar qualified person.

Ensure main supply is switched off.

- Mount the two expansion anchors (supplied) in the ceiling. (Fig. 1)
- Mount the ceiling bracket to the anchors with the screws provided. (Fig. 2)
- Connect the fitting to its electrical source using the terminal block provided. (Fig. 3)
Brown (Live) - to Brown or Red
Blue (Neutral) - to Blue or Black
Green/Yellow (Earth) - to Green/Yellow or Copper.
- Fix the fitting base to the ceiling bracket. (Fig. 4)
- Adjust the length of cable as needed. (Fig. 5)

Switch main supply back on and test the fitting.

WARNING:

- Ensure all items and screws are secure and fitted correctly.

SOHO AND BELTA PENDANT

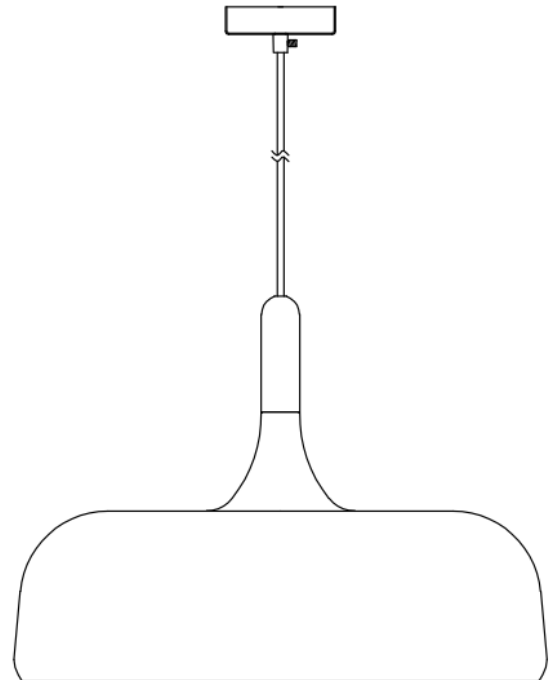
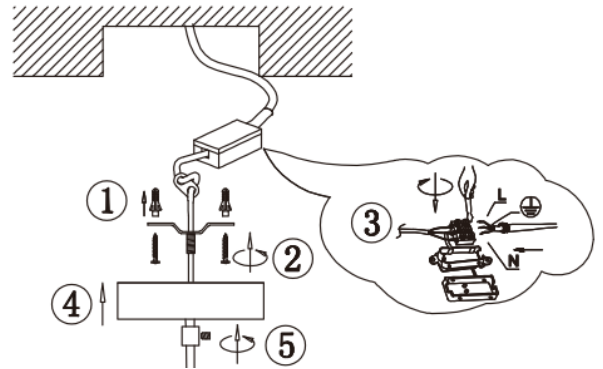

Spazio Lighting (Pty) LTD JOHANNESBURG OFFICE:

52 Andries Street North | Wynberg/Sandton | South Africa | Tel: +27 11 555 5555 Fax: +27 11 555 5544

CAPETOWN OFFICE:

36 Milner Road, Paarden Eiland | Tel: +27 21 461 0061 | Fax: +27 21 461 0063

info@spazio.co.za