

INSTRUCTIONS

SPAZIO

SPACE TABLE LAMP

8490

Please read the instructions before commencing use and retain for future reference.

SPECIFICATIONS:

- **Fitting:** Body made in stainless steel with fabric shade.
- **Lamp types:** max. 60W / E27
- **Protection against electric shock:** CLASS II. Does not require earth connection.
- **Ingress Protection:** IP20. Protection against the entry of solid bodies with dimensions more than 12mm.
- **Driver:** Not Applicable
- **Quality/Corrosive rating:** Suitable for indoor domestic and commercial indoor use only.
- **Ambient temperature range:** -20°C to +50°C.

WARNING:

Ensure all items and screws are secure and fitted correctly.

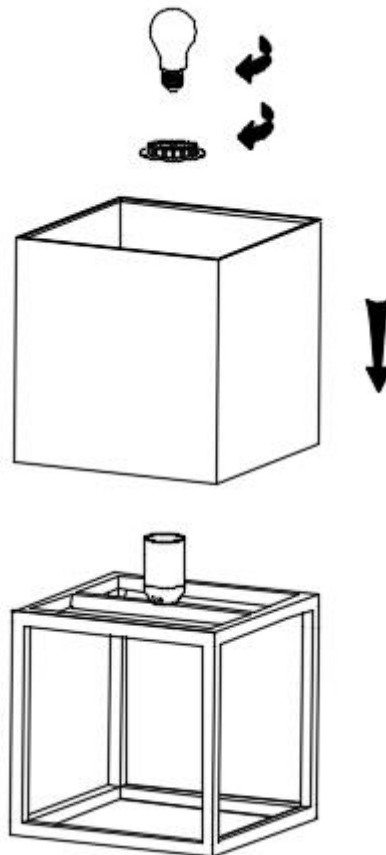

Spazio Lighting (Pty) LTD.

JOHANNESBURG OFFICE: 52 Andries Street | Wynberg/Sandton

CAPE TOWN OFFICE: 36 Milner Street | Paarden Eiland

DURBAN OFFICE: 31 Solstice Road | Umhlanga Ridge

011 555 5555 (Central Switchboard) | info@spazio.co.za