

# INSTRUCTIONS



## VANITY LIGHT

**SQUARE: 7060.3031 7060.4031**

**ROUND: 7061.3031 7061.4031**

Please read the instructions before commencing installation and retain for future reference.

### SPECIFICATIONS:

- **Fitting:** Polycarbonate body and diffuser
- **Lamp types:** 15W / LED 3000K + 4000K
- **Protection against electric shock:** CLASS II. Does not require earth connection.
- **Ingress protection:** IP44. Protection against the entry of solid bodies with dimensions more than 1mm and water splashes.
- **Driver:** Includes LED Driver
- **Quality/Corrosive rating:** Suitable for commercial use and indoor except in corrosive environments.
- **Ambient temperature range:** -20° to +45°

### INSTALLATION INSTRUCTIONS:

**⚠** Electrical products can cause death, injury or damage to property. Installation of this product must be carried out by a qualified electrician, in accordance with SANS 10142. On completion of installation, ensure that the Certificate of Compliance is updated.



**CAUTION:** Risk of electric shock

**PLEASE NOTE:** The light source contained on this luminaire is not replaceable.

### Switch off mains supply.

- Remove the end caps. **(Fig.1)**
- Mark and drill holes where you want to place the fitting and insert the expansion plugs. Open the plastic cover in the back side of the luminaire, thread the mains cable through the black rubber gasket and connect it to the terminal block:
  - Brown (Live) - to Brown or Red
  - Blue (Neutral) - to Blue or Black
  - Green/Yellow (Earth) - to Green/Yellow or Copper.
- Close the plastic cover and fix the luminaire to the wall. **(Fig.2)**
- Re-attach end caps to the luminaire. **(Fig.3)**

### Switch on mains supply.

**WARNING:** Ensure all parts are securely connected and place.

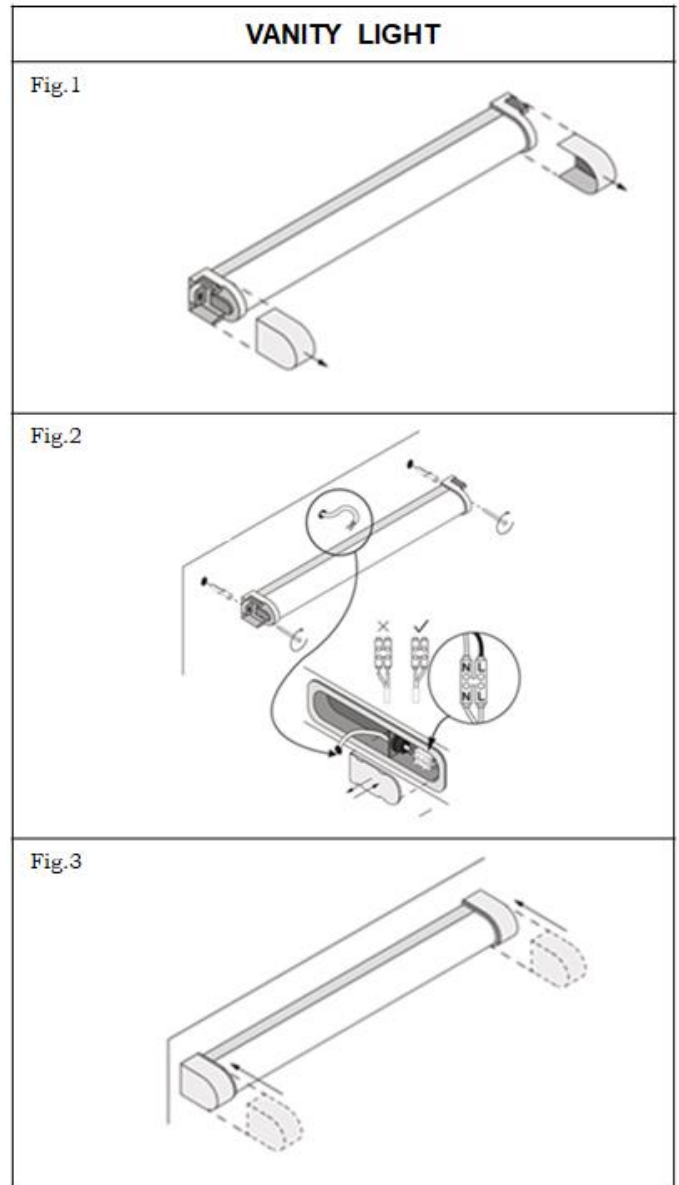

**Spazio Lighting (Pty) LTD.**

**JOHANNESBURG OFFICE:** 52 Andries Street | Wynberg/Sandton

**CAPETOWN OFFICE:** 36 Milner Street | Paarden Eiland

**DURBAN OFFICE:** 31 Solstice Road | Umhlanga Ridge

**011 555 5555 (Central Switchboard) | info@spazio.co.za**