

# INSTRUCTIONS

## GUCCI LED SPOT

4131.2.35.40.30.30 35W 4131.2.35.40.30.31 35W  
4131.2.35.40.40.30 35W 4131.2.35.40.40.31 35W



Please read the instructions before commencing installation and retain for future reference.

### SPECIFICATIONS:

- **Fitting:** Aluminum body with glass diffuser.
- **Lamp:** 35W / LED 3000 or 4000K
- **Protection against electric shock:** CLASS I requires earth connection.
- **Ingress Protection:** IP20. Protection against the entry of solid bodies with dimensions more than 12mm.
- **Driver:** Includes Integral LED driver
- **Quality/Corrosive rating:** Suitable for Commercial use, indoor except in corrosive environments.
- **Ambient temperature range:** -20°C to +40°C.

### INSTALLATION INSTRUCTIONS:

**⚠** Electrical products can cause death, injury, damage to property. Installation of this product must be carried out by a qualified electrician, in accordance with SANS 10142. On completion of installation, ensure that the Certificate of Compliance is updated.

- Ensure mains supply is switched off.
- Connect the supplied cable on the light fitting to the main power supply. Please ensure that the connection is done in a waterproof housing in accordance with SANS 10142. Never replace the cable supplied with the light fitting.
- Track mount ( **Fig.1** ) - Ensure track adapter is correctly and securely .

Step 1. Place the adapter into the track correctly

Step 2. Push the button to lock the adapter

- Adjust beam directions ( **Fig.2** )  
Tilting 0 - 180°  
Horizontal: 0 - 355°
- Please ensure that the bracket and cable are installed according to the instructions. Power can be turned on only after all processes are checked.

### WARNING:

- This fitting must be earthed.
- Ensure all items and screws are tight.
- The use of silicon sealer or failure to use correct cable will void the warranty.

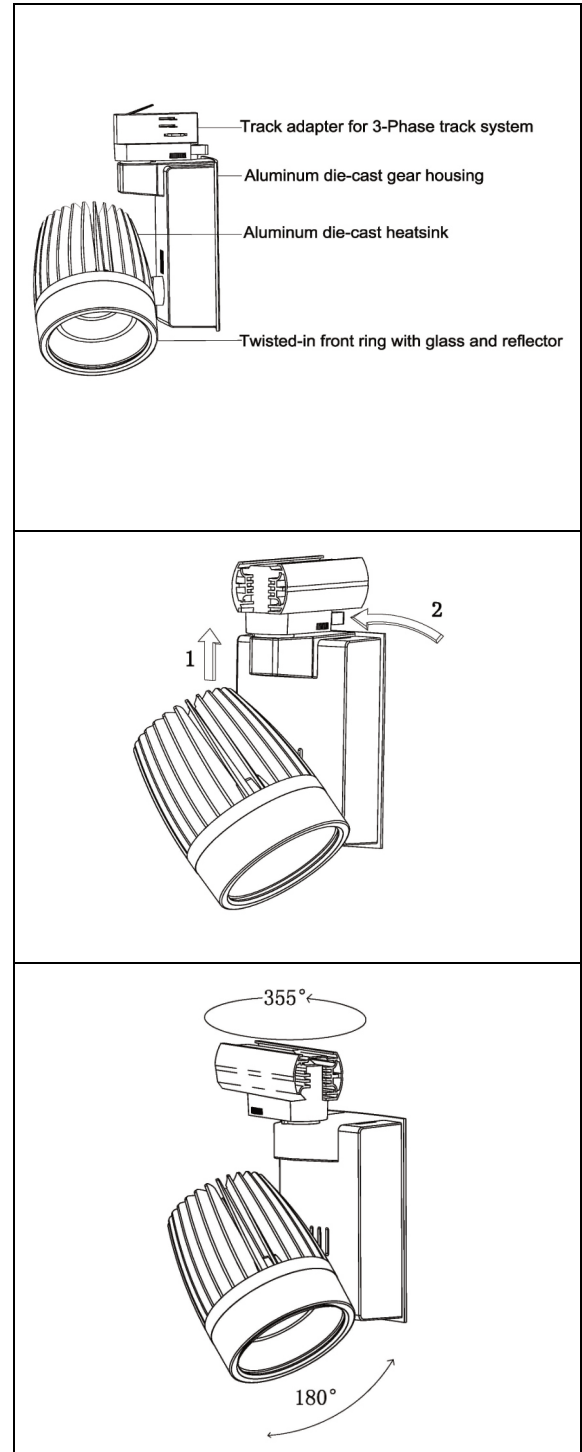

Spazio Lighting (Pty) LTD.

JOHANNESBURG OFFICE: 52 Andries Street | Wynberg/Sandton

CAPE TOWN OFFICE: 36 Milner Street | Paarden Eiland

DURBAN OFFICE: 31 Solstice Road | Umhlanga Ridge

011 555 5555 (Central Switchboard) | [info@spazio.co.za](mailto:info@spazio.co.za)