

INSTRUCTIONS



ACTROS LED DOWNLIGHT

2858.25.60.30.31 3000K 2858.25.60.40.31 4000K
 2858.35.60.30.31 3000K 2858.35.60.40.31 4000K
 2858.45.60.30.31 3000K 2858.45.60.40.31 4000K

Please read the instructions before commencing installation and retain for future reference.

SPECIFICATIONS:

- **Fitting:** Die-cast aluminum.
- **Lamp types:** 25W / 35W / 45W 230V LED.
- **Protection against electric shock:** CLASS II: Does not require earth connection.
- **Ingress Protection:** IP20
- **Quality/ Corrosive rating:** Suitable for Commercial use, indoor, except in corrosive environments.
- **Ambient temperature range:** -20°C to +40°C.

INSTALLATION INSTRUCTIONS:

⚠ Electrical products can cause death, injury or damage to property. Installation of this product must be carried out by a qualified electrician, in accordance with SANS 10142. On completion of installation, ensure that the Certificate of Compliance is updated.

Ensure mains supply is switched off

- It is important to ensure the correct spacing between the building structure and the fitting (Fig. 1) Area above fitting (A): 50mm Structure membrane (B): 30mm Thermal Insulation (C): 30mm
- Make the correct cut out in the ceiling (See Table Fig.2)
- Connect the fitting to the power supply:
 Brown (Live) - to Brown or Red
 Blue (Neutral) - to Blue or Black
- Place the fitting into the ceiling

Turn on the mains supply

Fig. 1

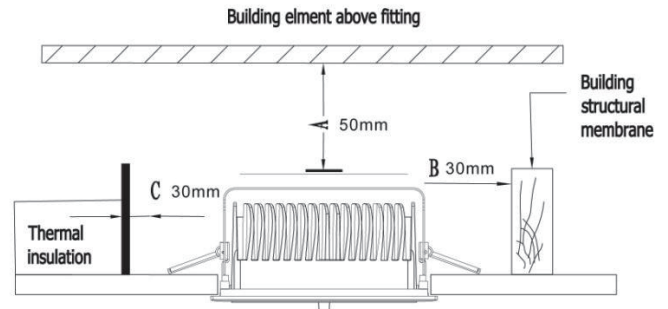

Fig.2

Power	Downlight(mm)	Ceiling Cutout(mm)
25W	Ø145*65mm	120-130mm
35W	Ø190*75mm	160-170mm
45W	Ø225*87mm	200-210mm

IMPORTANT:

- Ensure all items and screws are tight.
- Do not make any randoms modifications to the fitting
- This product is not suitable for damp or corrosive environments

NB! Dimmable version operates with a Triac dimmer only

Spazio Lighting (Pty) LTD.

JOHANNESBURG OFFICE: 52 Andries Street | Wynberg/Sandton

CAPETOWN OFFICE: 36 Milner Road | Paarden Eiland

DURBAN OFFICE : 31 Solstice Road | Umhlanga Ridge

011 555 5555 (Central Switchboard) | info@spazio.co.za