

INSTRUCTIONS

2476 SPLASH PROOF DOWNLIGHT

2476/31

Please read the instructions before commencing installation and retain for future reference.



SPECIFICATIONS:

- **Fitting:** Aluminum
- **Lamp types:** 10W / 230V / Gu10 LED
- **Protection against electric shock:** Class 1, requires earth connection
- **Ingress Protection:** IP65. Protection against the entry of solid bodies greater than 12mm
- **Ballast:** Not required
- **Quality/Corrosive rating:** Suitable domestic and commercial indoor use, except in corrosive environments
- **Ambient temperature range:** -20°C to + 80°C.

INSTALLATION INSTRUCTIONS:

⚠ Electrical products can cause death, injury, damage to property. Installation of this product must be carried out by a qualified electrician, in accordance with SANS 10142. On completion of installation, ensure that the Certificate of Compliance is updated.



CAUTION: Risk of electric shock

Ensure mains supply is switched off

- Cut a hole in the ceiling as per the recommended cut out size (Fig. 1)
- Connect the lamp holder to the mains supply via the terminal block provided on the lamp holder bracket (Fig. 2)
- Remove the twist off diffuser and retaining ring from the fitting. (Fig. 2)
- Fit the lamp into the lamp holder and fix into position with the retaining ring (Fig 3).
- Insert the fitting into the cut out ensuring that the mains lead is not trapped. Push the mounting clips upwards to snap the fitting firmly into position, flush with the ceiling. (Fig. 4).
- Switch on mains supply.

WARNING:

- Ensure all items and screws are tight.
- Do not operate/install any product which appears damaged in any way.
- If damaged return the complete product to the place of purchase for inspection, repair or replacement.
- Ensure there are no components missing before commencing installation

2476 SPLASH PROOF DOWN LIGHT

1.

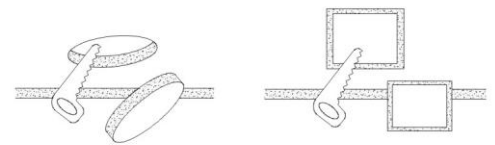

2.

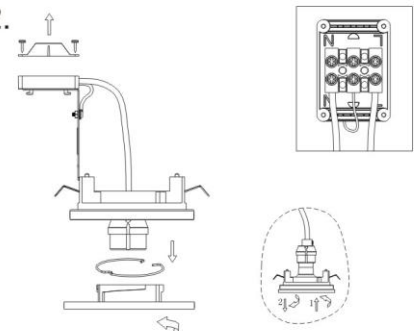

3.

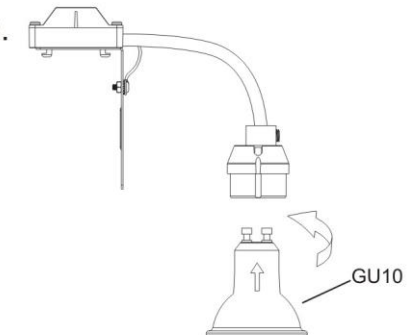

4.

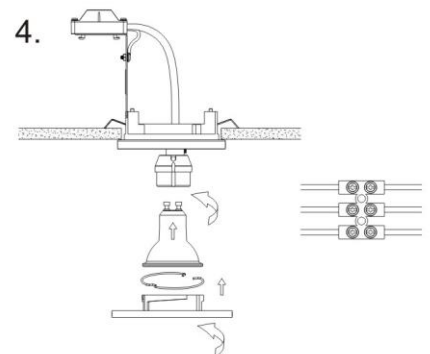

Spazio Lighting (Pty) LTD.

JOHANNESBURG OFFICE: 52 Andries Street | Wynberg/Sandton

CAPE TOWN OFFICE: 36 Milner Street | Paarden Eiland

DURBAN OFFICE: 31 Solstice Road | Umhlanga Ridge

011 555 5555 (Central Switchboard) | info@spazio.co.za