

# INSTRUCTIONS

## LONE TRACK SPOT

246605.2.30

246605.2.31

Please read the instructions before commencing installation and retain for future reference.

### SPECIFICATIONS:

- **Fitting:** Extruded aluminum body
- **Lamp types:** 10W / 230V / GU10 Suitable for GU10 LED's
- **Protection against electric shock:** CLASS I. Requires earth connection.
- **Ingress Protection:** IP20. Protection against the entry of solid bodies greater than 12mm.
- **Driver:** Not applicable
- **Quality/Corrosive rating:** Suitable for commercial and domestic indoor applications.
- **Ambient temperature range:** -8°C to +55°C.

### INSTALLATION INSTRUCTIONS:

**⚠** Electrical products can cause death, injury or damage to property. Installation of this product must be carried out by a qualified electrician, in accordance with SANS 10142. On completion of installation, ensure that the Certificate of Compliance is updated.



**CAUTION:** Risk of electric shock

**Ensure mains supply is switched off.**

- Connect the electrical cable to the track power feed using the terminal block provided (Fig.1)
  - Brown (Live) - to Brown or Red
  - Blue (Neutral) - to Blue or Black
  - Green/Yellow (Earth) - to Green/Yellow or Copper.
- Fix the fitting to the track line. (Fig.2)
- Insert the lamp. (Fig.3)

**Switch main supply back on.**

### WARNING:

- Ensure all items and screws are secure and fitted correctly.



## LONE TRACK SPOT

Fig.1

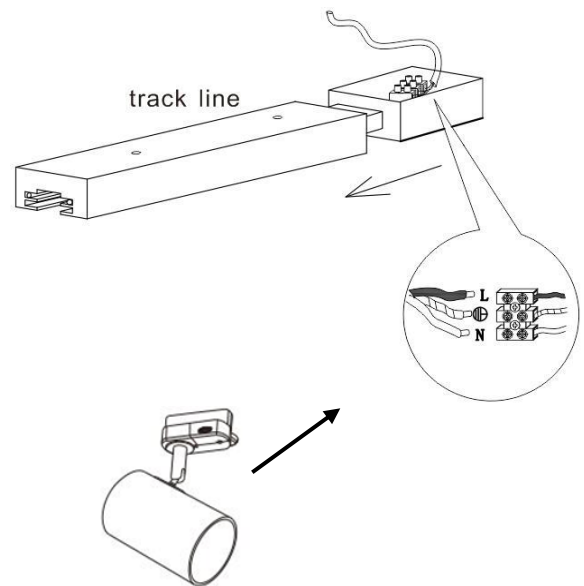

Fig.2

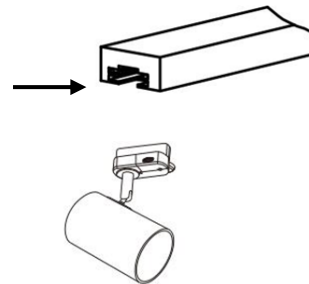
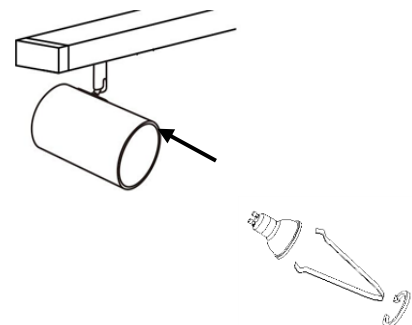

Fig.3



**Spazio Lighting (Pty) LTD.**

**JOHANNESBURG OFFICE:** 52 Andries Street | Wynberg/Sandton

**CAPE TOWN OFFICE:** 36 Milner Street | Paarden Eiland

**DURBAN OFFICE:** 31 Solstice Road | Umhlanga Ridge

**011 555 5555 (Central Switchboard) | [info@spazio.co.za](mailto:info@spazio.co.za)**