

INSTRUCTIONS

ANTI GLARE D/L SQUARE

2352/3031

Please read the instructions before commencing installation and retain for future reference.

SPECIFICATIONS:

- **Fitting:** Aluminum
- **Lamp types:** 10W / GU10
- **Protection against electric shock:** Class I. Requires earth connection
- **Ingress Protection:** IP20. Protection against the entry of solid bodies greater than 12mm
- **Driver:** Not Applicable
- **Quality/Corrosive rating:** Suitable for indoor domestic and commercial use, except in corrosive environments.
- **Ambient temperature range:** -20°C to + 80°C.

INSTALLATION INSTRUCTIONS:

 Electrical products can cause death, injury, damage to property. Installation of this product must be carried out by a qualified electrician, in accordance with SANS 10142. On completion of installation, ensure that the Certificate of Compliance is updated.



CAUTION: Risk of electric shock

Ensure mains supply is switched off

- Cut a hole in the ceiling as per the recommended cut out size (Fig. 1)
- Connect the lamp holder to the mains supply via the terminal block provided on the bracket (Fig. 2)
Brown (Live) - to Brown or Red
Blue (Neutral) - to Blue or Black
Green/Yellow (Earth) - to Green/Yellow or Copper.
- Insert the fitting into the cut out ensuring that the mains lead is not trapped. Push the mounting clips upwards to snap the fitting firmly in place (Fig. 3)
- Remove the retaining ring from the fitting. (Fig. 4)
- Fit the lamp into the lamp holder and fix it into position with the retaining ring. (Fig 5).

Switch on mains supply.

WARNING:

- Ensure all items and screws are tight.
- Do not operate/install any product which appears damaged in any way.
- If damaged, return the complete product to the place of purchase for inspection, repair or replacement.
- Ensure there are no components missing before commencing installation

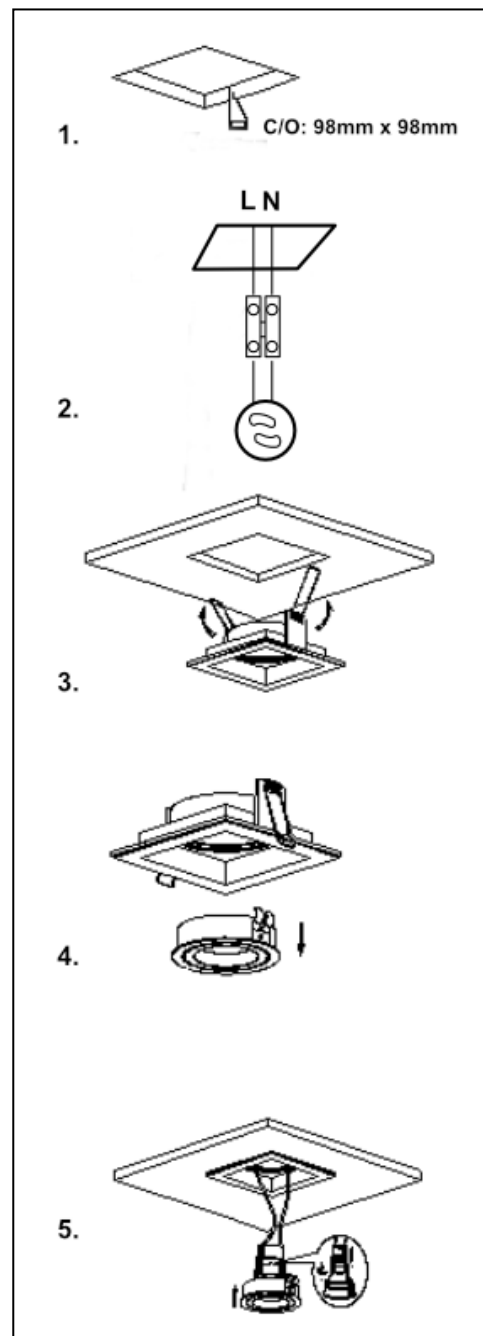

Spazio Lighting (Pty) LTD.

JOHANNESBURG OFFICE: 52 Andries Street | Wynberg/Sandton

CAPE TOWN OFFICE: 36 Milner Street | Paarden Eiland

DURBAN OFFICE: 31 Solstice Road | Umhlanga Ridge

011 555 5555 (Central Switchboard) | info@spazio.co.za