

Application Specific Blowers

MD 101 Magnetic-Drive

Regenerative Blower

ROTRON®

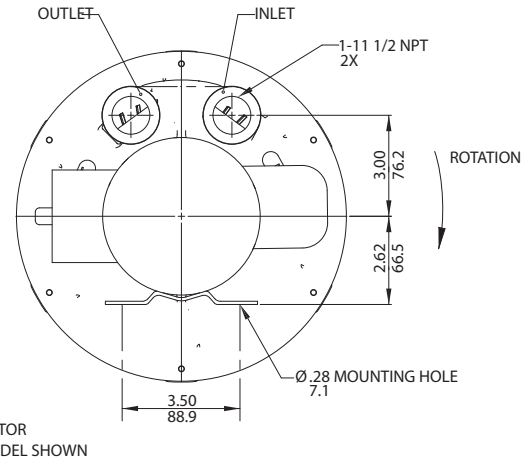
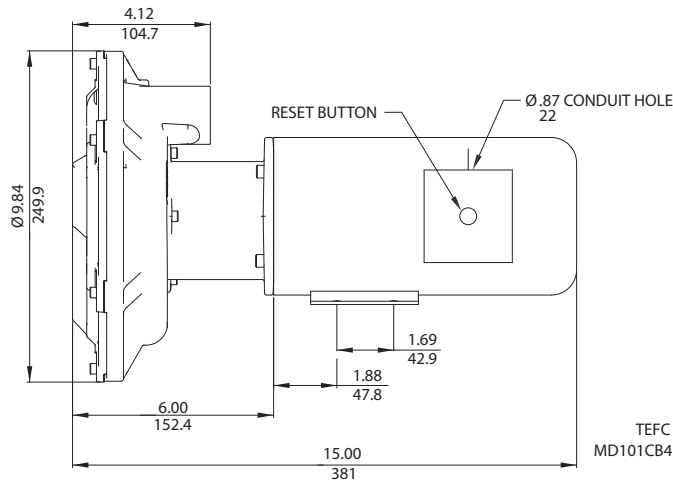

TEFC MOTOR
MD101CB4 MODEL SHOWN

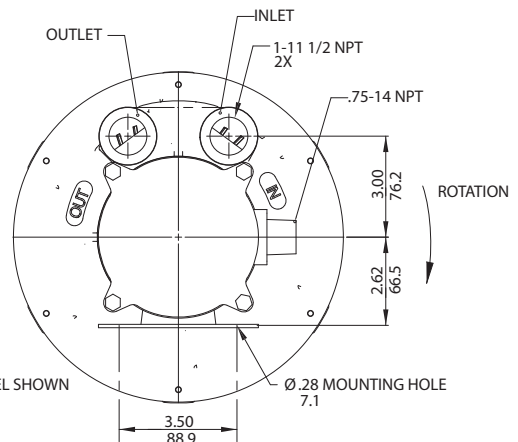
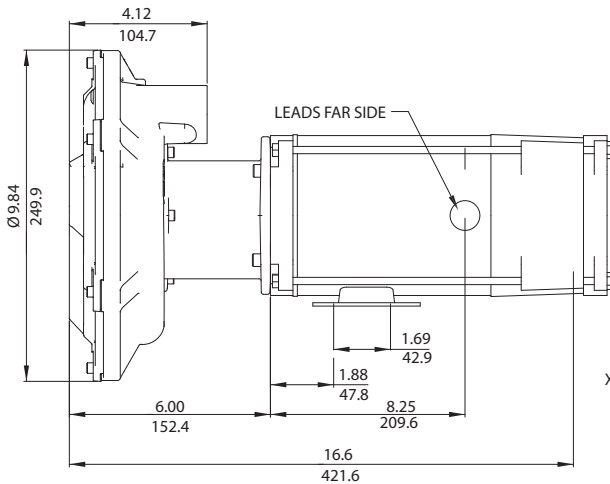

XP MOTOR
MD101CC4 MODEL SHOWN

NOTES

- 1 DRAWING NOT TO SCALE, CONTACT FACTORY FOR SCALE CAD DRAWING.
- 2 CONTACT FACTORY FOR BLOWER MODEL LENGTHS NOT SHOWN.

Specification	Units	Part/Model Number	
		MD101CB4 038014	MD101CC4 038271
Motor Enclosure - Shaft Mtl.	-	TEFC	Explosion-proof
Horsepower	-	.25	.25
Phase - Frequency Voltage	-	Single-60 hz	Single-60 hz
Motor Nameplate Amps	AC	115	115
Max. Blower Amps	Amps (A)	2.6	2.6
Locked Rotor Amps	Amps (A)	2.2	2.2
Service Factor	Amps (A)	6.4	7.2
Starter Size	-	1.0	1.0
Thermal Protection	-	00	00
XP Motor Class - Group	-	Class B - Automatic, Manual Reset	Class B - Automatic
Shipping Weight	Lbs	40	40
	Kg	18.1	18.1

¹ Maximum operating temperature: Motor winding temperature (winding rise plus ambient) should not exceed 140°C for Class F rated motors or 120°C for Class B rated motors. Blower outlet air temperature should not exceed 140°C (air temperature rise plus inlet temperature). Performance curve maximum pressure and suction points are based on a 40°C inlet and ambient temperature. Consult factory for inlet or ambient temperatures above 40°C.

This document is for informational purposes only and should not be considered as a binding description of the products or their performance in all applications. The performance data on this page depicts typical performance under controlled laboratory conditions. AMETEK is not responsible for blowers driven beyond factory specified speed, temperature, pressure, flow or without proper alignment. Actual performance will vary depending on the operating environment and application. AMETEK products are not designed for and should not be used in medical life support applications. AMETEK reserves the right to revise its products without notification. The above characteristics represent standard products. For product designed to meet specific applications, contact AMETEK Technical & Industrial Products Sales department.

AMETEK DYNAMIC FLUID SOLUTIONS
75 North Street, Saugerties, NY 12477
USA: +1 215-256-6601 - Europe: +49 7703 930909 - Asia: +86 21 5763 1258
Customer Service Fax: +1 215.256.1338
www.ametekdfs.com

Application Specific Blowers

MD 101 Magnetic-Drive

Regenerative Blower

FEATURES

- Hermetically designed seal-less blower
- Continuous operation
- Manufactured in the USA
- Maximum flow: 27 SCFM
- Maximum pressure: 28 IWG
- Maximum vacuum: 26.5 IWG
- Standard motor: 0.25 HP, TEFC or XP
- Disconnect motor without disassembling from piping
- Cast aluminum blower housing, impeller & flanges
- Permanently sealed ball bearings in housing and motor
- Quiet operation within OSHA standards
- Contact factory for leakage specifications

BLOWER OPTIONS

- Corrosion resistant surface treatments & sealing options

ACCESSORIES

- Flowmeters reading in SCFM
- Filters & moisture separators
- Pressure gauges, vacuum gauges, & relief valves
- External mufflers for additional silencing

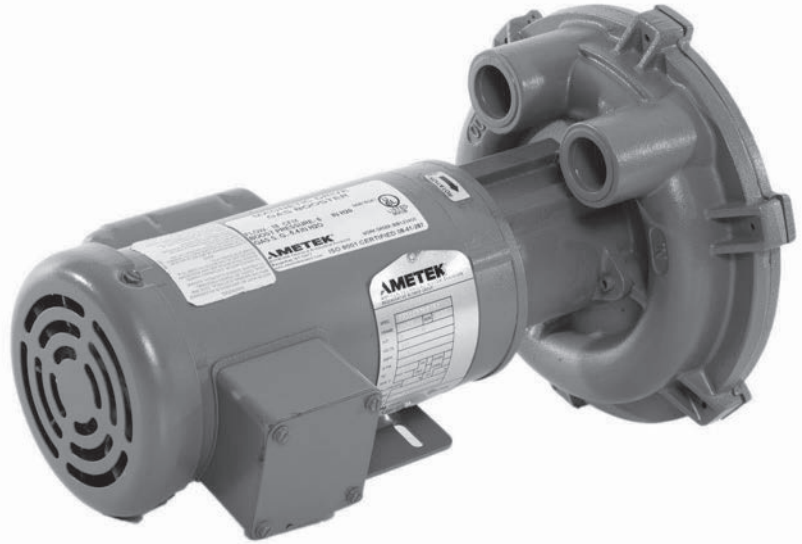

Blower Performance at Standard Conditions

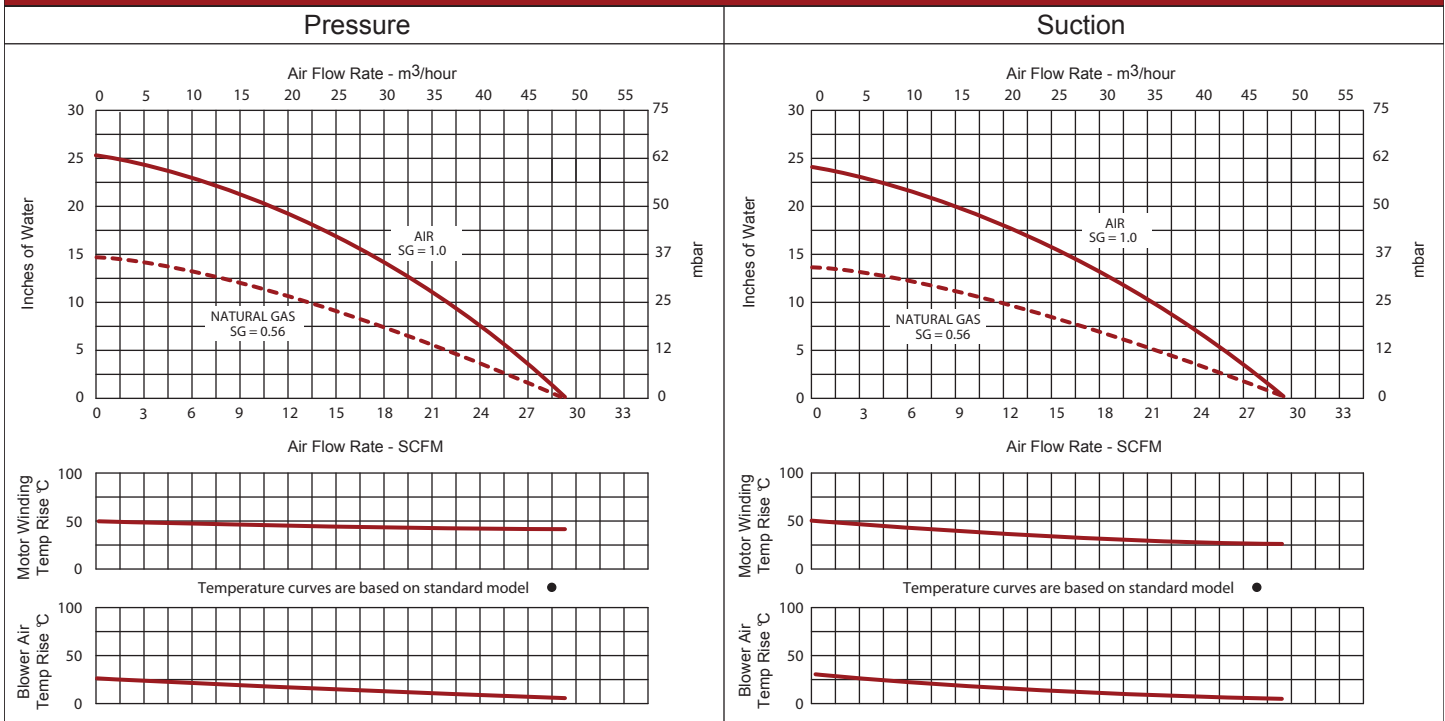

This document is for informational purposes only and should not be considered as a binding description of the products or their performance in all applications. The performance data on this page depicts typical performance under controlled laboratory conditions. AMETEK is not responsible for blowers driven beyond factory specified speed, temperature, pressure, flow or without proper alignment. Actual performance will vary depending on the operating environment and application. AMETEK products are not designed for and should not be used in medical life support applications. AMETEK reserves the right to revise its products without notification. The above characteristics represent standard products. For product designed to meet specific applications, contact AMETEK Technical & Industrial Products Sales department.

AMETEK DYNAMIC FLUID SOLUTIONS
 75 North Street, Saugerties, NY 12477
 USA: +1 215-256-6601 - Europe: +49 7703 930909 - Asia: +86 21 5763 1258
 Customer Service Fax: +1 215.256.1338
www.ametekdfs.com