

# Remote Drive (Motorless) Blowers

**DR/EN/CP 404RD**

# ROTRON®

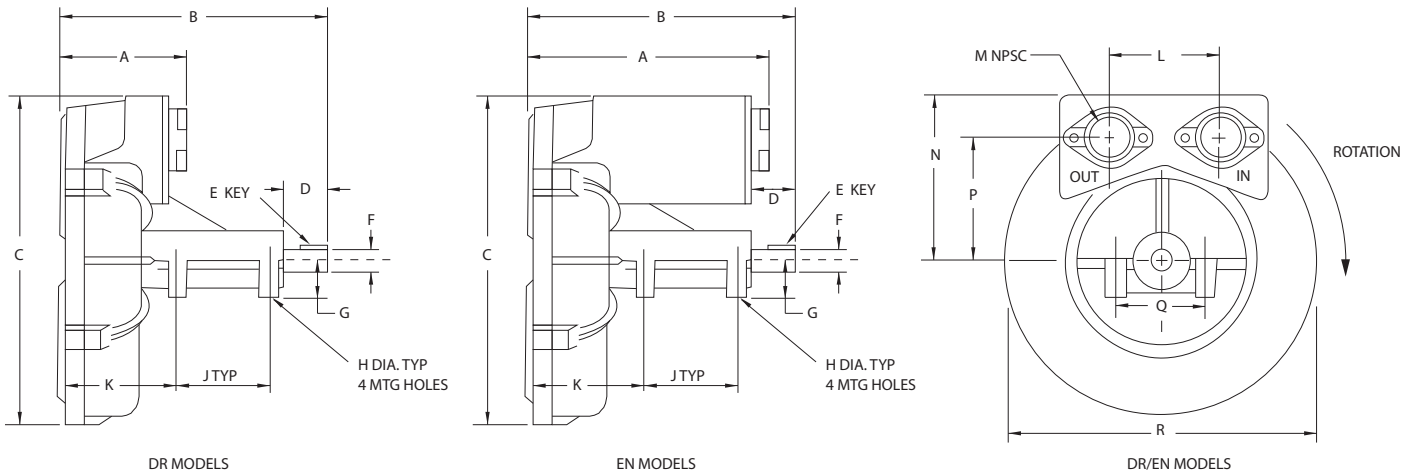

NOTES  
 1 DRAWING NOT TO SCALE, CONTACT FACTORY FOR SCALE CAD DRAWING.  
 2 CONTACT FACTORY FOR BLOWER MODEL LENGTHS NOT SHOWN.

		Specification IN/MM															
Model Number	Part Number	A	B	C	D	E	F	G	J	H	K	L	M	N	P	Q	R
DR404RDNT	036439	5.60	11.5	12.2	2.00	.188	.875	1.56	4.00	.50	5.00	5.12	1.50	6.17	4.5	4.00	11.54
		142.2	292.1	309.9	50.8	4.8	22.2	39.6	101.6	12.7	127	130	38.1	156.7	114.3	101.6	293.1
EN404RDML	038334	12.76	11.50	12.2	2.00	.188	.875	1.56	4.00	.50	5.00	5.12	1.50	6.17	4.5	4.00	11.54
		324.1	292.1	309.9	50.8	4.8	22.2	39.6	101.6	12.7	127	130	38.1	156.7	114.3	101.6	293.1

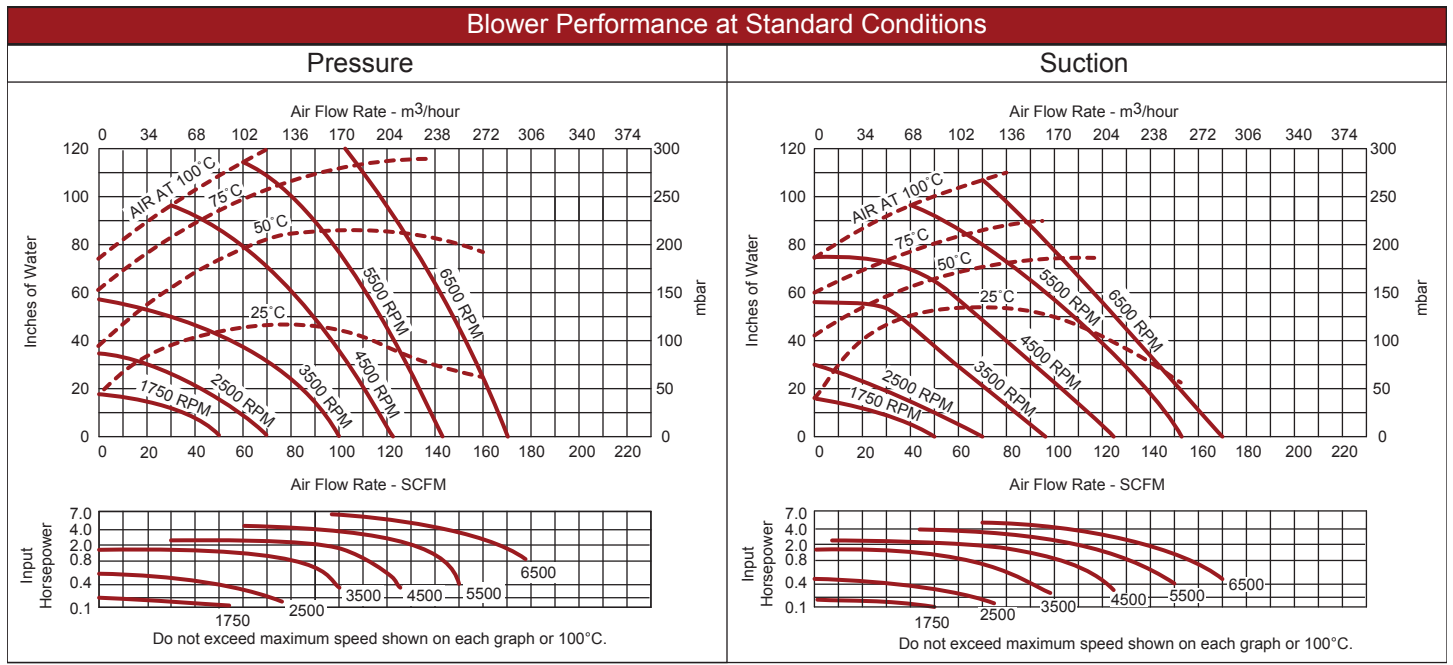

*This document is for informational purposes only and should not be considered as a binding description of the products or their performance in all applications. The performance data on this page depicts typical performance under controlled laboratory conditions. AMETEK is not responsible for blowers driven beyond factory specified speed, temperature, pressure, flow or without proper alignment. Actual performance will vary depending on the operating environment and application. AMETEK products are not designed for and should not be used in medical life support applications. AMETEK reserves the right to revise its products without notification. The above characteristics represent standard products. For product designed to meet specific applications, contact AMETEK Technical & Industrial Products Sales department.*

**AMETEK DYNAMIC FLUID SOLUTIONS**  
 75 North Street, Saugerties, NY 12477  
 USA: +1 215-256-6601 - Europe: +49 7703 930909 - Asia: +86 21 5763 1258  
 Customer Service Fax: +1 215.256.1338  
[www.ametekdfs.com](http://www.ametekdfs.com)