

20.0 / 30.0 HP Regenerative Blower

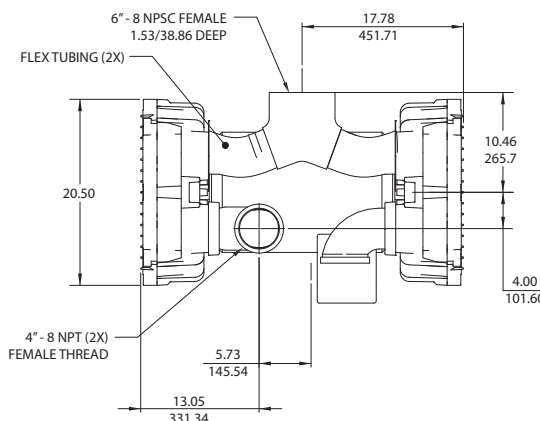
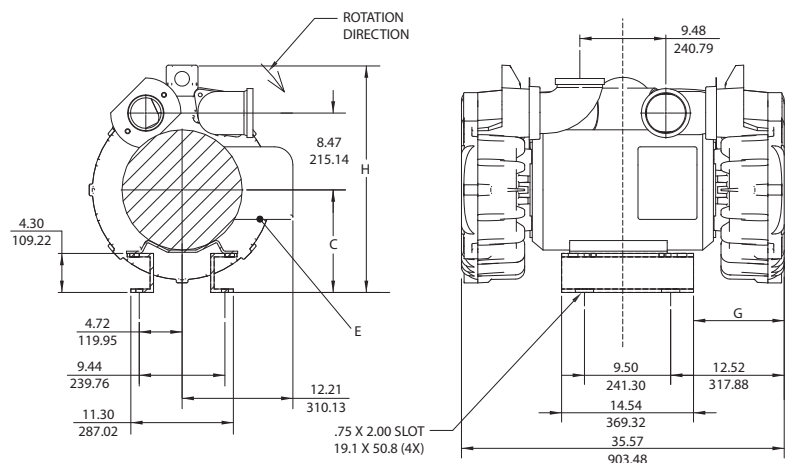

IN
MM

NOTES

- 081801 DRP13BP72C MODEL SHOWN.
- DRAWING NOT TO SCALE, CONTACT FACTORY FOR SCALE CAD DRAWING.
- CONTACT FACTORY FOR BLOWER MODEL LENGTHS NOT SHOWN.

PART NUMBER	MODEL	C IN/MM	H IN/MM	G IN/MM	E IN/MM
081801	DRP13BP72C	11.30/287	25.01/635.25	12.52/317.88	2/50.8
081802	DRP13BP72D	11.30/287	25.01/635.25	12.52/317.88	2/50.8
081804	DRP13BP86C	11.30/287	25.04/635.25	12.52/317.88	2/50.8
081805	DRP13BP86D	11.30/287	25.04/635.25	12.52/317.88	2/50.8
081798	DRP13BM72C	10.55/267.97	24.26/616.11	10.77/273.43	1.38/35.05
081797	DRP13BM72D	10.55/267.97	24.26/616.11	10.77/273.43	1.38/35.05

Specification	Units	Part/ Model Number					
		DRP13BP72C 081801	DRP13BP72D 081802	DRP13BP86C 081804	DRP13BP86D 081805	DRP13BM72C 081798	DRP13BM72D 081797
Motor Enclosure - Shaft Mtl.	-	ODP-CS	ODP-CS	ODP-CS	ODP-CS	ODP-CS	ODP-CS
Horsepower	-	30	30	30	30	20	20
Voltage	AC	230/460	230/460	575	575	230/460	230/460
Phase - Frequency	-	Three-60 hz	Three-60 hz	Three-60 hz	Three-60 hz	Three-60 hz	Three-60 hz
Insulation Class	-	F	F	F	F	F	F
NEMA Rated Motor Amps	Amps (A)	70/35	70/35	28	28	49/24.5	49/24.5
Service Factor	-	1.15	1.15	1.15	1.15	1.15	1.15
Locked Rotor Amps	Amps (A)	380/190	380/190	174	174	306/153	306/153
Max. Blower Amps	Amps (A)	110/55	110/55	36	36	64/32	64/32
NEMA Starter Size	-	3/3	3/3	3	3	3/2	3/2
Shipping Weight	Lbs	687	687	687	687	592	592
	Kg	311.6	311.6	311.6	311.6	268.5	268.5
Description	-	Pressure Mode	Suction Mode	Pressure Mode	Suction Mode	Pressure Mode	Suction Mode

Voltage - ROTRON motors are designed to handle a broad range of world voltages and power supply variations. Our dual voltage 3 phase motors are factory tested and certified to operate on both: **208-230/415-460 VAC-3 ph-60 Hz** and **190-208/380-415 VAC-3 ph-50 Hz**. Our dual voltage 1 phase motors are factory tested and certified to operate on both: **104-115/208-230 VAC-1 ph-60 Hz** and **100-110/200-220 VAC-1 ph-50 Hz**. All voltages above can handle a ±10% voltage fluctuation. Special wound motors can be ordered for voltages outside our certified range.

Operating Temperatures - Maximum operating temperature: Motor winding temperature (winding rise plus ambient) should not exceed 140°C for Class F rated motors or 120°C for Class B rated motors. Blower outlet air temperature should not exceed 140°C (air temperature rise plus inlet temperature). Performance curve maximum pressure and suction points are based on a 40°C inlet and ambient temperature. Consult factory for inlet or ambient temperatures above 40°C.

Maximum Blower Amps - Corresponds to the performance point at which the motor or blower temperature rise with a 40°C inlet and/or ambient temperature reaches the maximum operating temperature.

This document is for informational purposes only and should not be considered as a binding description of the products or their performance in all applications. The performance data on this page depicts typical performance under controlled laboratory conditions. AMETEK is not responsible for blowers driven beyond factory specified speed, temperature, pressure, flow or without proper alignment. Actual performance will vary depending on the operating environment and application. AMETEK products are not designed for and should not be used in medical life support applications. AMETEK reserves the right to revise its products without notification. The above characteristics represent standard products. For product designed to meet specific applications, contact AMETEK Technical & Industrial Products Sales department.

DR P13

20.0 / 30.0 HP Regenerative Blower

FEATURES

- Manufactured in the USA - ISO 9001 and NAFTA compliant
- CE compliant - Declaration of Conformity on file
- Maximum flow: 1150 SCFM
- Maximum pressure: 115 IWG
- Maximum vacuum: 103 IWG
- Standard motor: 30 HP, ODP
- Cast aluminum blower housing, impeller & cover; cast iron flanges (threaded)
- UL & CSA approved motor with permanently sealed ball bearings
- Inlet & outlet internal muffling
- Quiet operation within OSHA standards when properly piped or muffled - 2 mufflers included (part# 511569)

MOTOR OPTIONS

- International voltage & frequency (Hz)
- Chemical duty, high efficiency, inverter duty or industry-specific designs
- Various horsepower for application-specific needs

BLOWER OPTIONS

- Corrosion resistant surface treatments & sealing options
- Remote drive (motorless) models
- Slip-on or face flanges for application-specific needs

ACCESSORIES

- Flowmeters reading in SCFM
- Filters & moisture separators
- Pressure gauges, vacuum gauges, & relief valves
- Switches - air flow, pressure, vacuum, or temperature
- External mufflers for additional silencing
- Air knives (used on blow-off applications)
- Variable frequency drive package

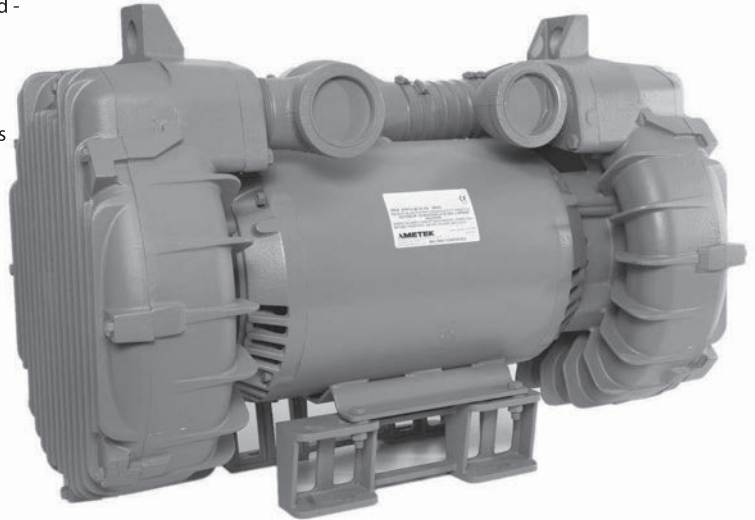

Blower Performance at Standard Conditions

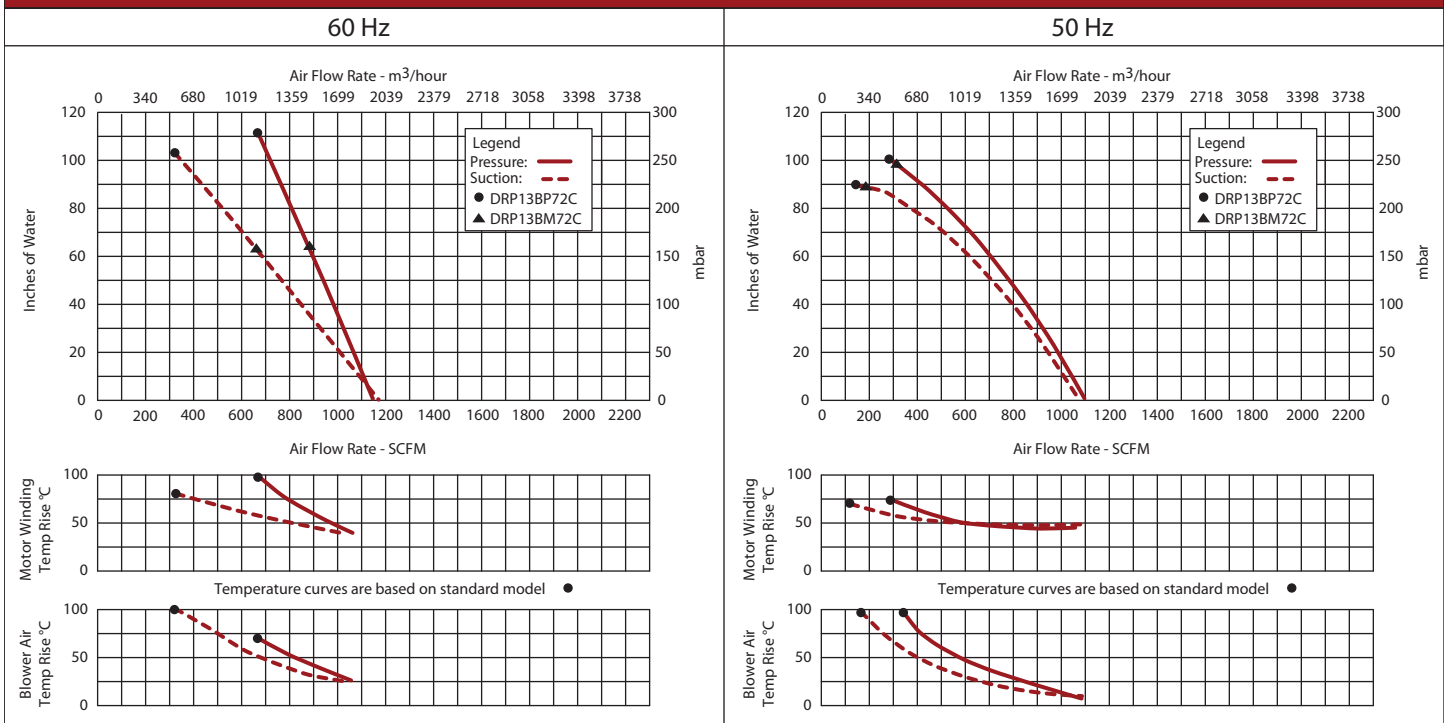

This document is for informational purposes only and should not be considered as a binding description of the products or their performance in all applications. The performance data on this page depicts typical performance under controlled laboratory conditions. AMETEK is not responsible for blowers driven beyond factory specified speed, temperature, pressure, flow or without proper alignment. Actual performance will vary depending on the operating environment and application. AMETEK products are not designed for and should not be used in medical life support applications. AMETEK reserves the right to revise its products without notification. The above characteristics represent standard products. For product designed to meet specific applications, contact AMETEK Technical & Industrial Products Sales department.