

Low Voltage Brushless DC Blowers

5.7" (145mm) BLDC Bypass Blower

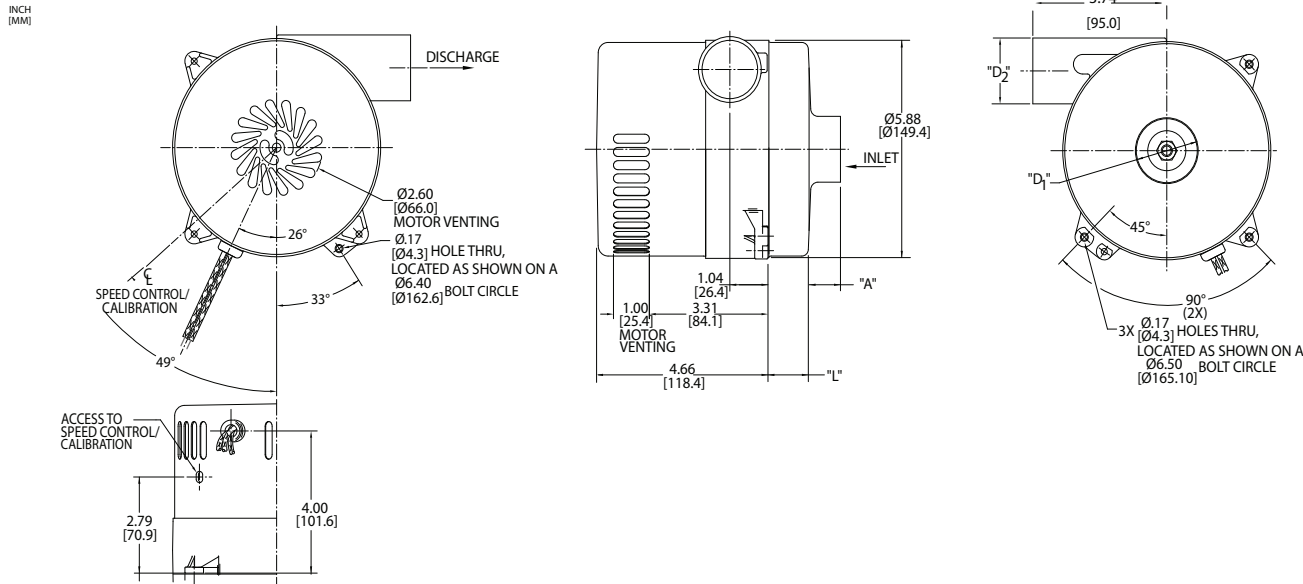

24 VDC Input, High Flow System



Specification	Units	Part/ Model Number					
		150403	150434	150404	150435	150405	150436
Flow	-	High Flow	High Flow	High Flow	High Flow	Ultra High Flow	Ultra High Flow
Stages	-	1	1	2	2	1	1
Input Voltage	VDC	24	24	24	24	24	24
Max Sealed Pressure	in. H ₂ O	34	34	57	57	22	22
	mbar	84.7	84.7	142	142	54.8	54.8
Max Open Flow Rate	CFM	126	126	101	101	190	190
	m ³ /hr	214.2	214.2	171.7	171.7	323	323
Inlet Diameter D1	Inches	1.75	1.75	1.75	1.75	2.75	2.75
	mm	44.5	44.5	44.5	44.5	69.9	69.9
Discharge Diameter D2	Inches	1.75	1.75	1.75	1.75	2.5	2.5
	mm	44.5	44.5	44.5	44.5	63.5	63.5
Length (L)	Inches	0.50	0.50	1.50	1.50	0.75	0.75
	mm	12.7	12.7	38.1	38.1	19.1	19.1
Speed Control	-	Anlg. Spd. Cmd.	Potent. Adjust.	Anlg. Spd. Cmd.	Potent. Adjust.	Anlg. Spd. Cmd.	Potent. Adjust.

Notes:

- **Temperature:** Working Air: 0°C to 45°C, Ambient Air: 0°C to 45°C, Storage: -40°C to 85°C.
- When used as a vacuum, the blower performance might be less than shown herein, depending on the operating point.
- **Weight** = 6 lb / 2.2 Kg

Potentiometer Adjustment (Potent. Adjust.) - The specified supply voltage is applied and the speed is set by adjusting a potentiometer on the side of the blower.

Analog Speed Command (Anlg. Spd. Cmd.) - Blower speed is proportional to an analog speed command signal. The range over which the speed command signal operates can be calibrated within 0-10V by adjusting the sensitivity potentiometer accessed through the side of the blower. The sensitivity adjustment is also useful for precisely calibrating a group of blowers to the same speed for a given operating point and command signal voltage.

Tachometer Output - All of the models listed above come equipped with a tachometer output: a square wave output that is proportional to blower speed. The frequency of the tachometer output signal is 2x the blower's rotational frequency.

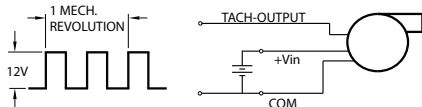

This document is for informational purposes only and should not be considered as a binding description of the products or their performance in all applications. The performance data on this page depicts typical performance under controlled laboratory conditions. AMETEK is not responsible for blowers driven beyond factory specified speed, temperature, pressure, flow or without proper alignment. Actual performance will vary depending on the operating environment and application. AMETEK products are not designed for and should not be used in medical life support applications. AMETEK reserves the right to revise its products without notification. The above characteristics represent standard products. For product designed to meet specific applications, contact AMETEK Dynamic Fluid Solutions Sales department.

Typical Performance

(at constant 24V input)
Flow (m³/hr)

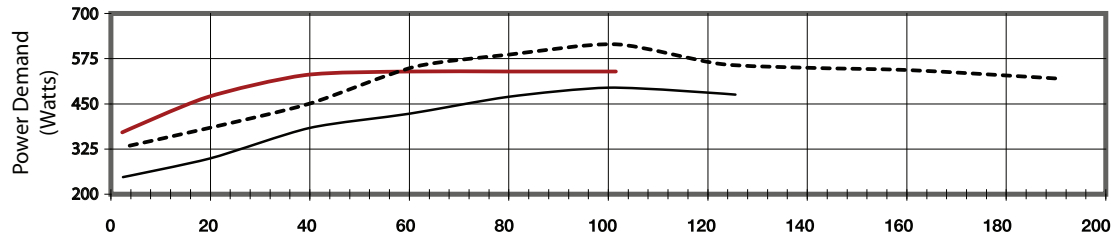
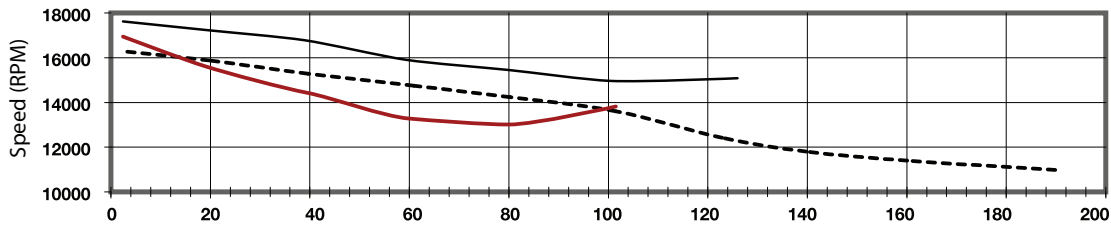
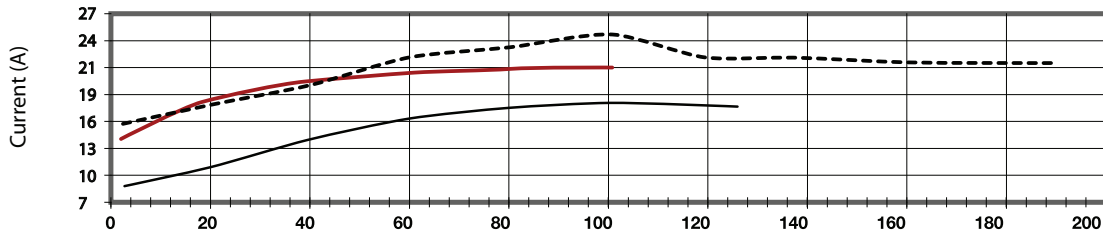
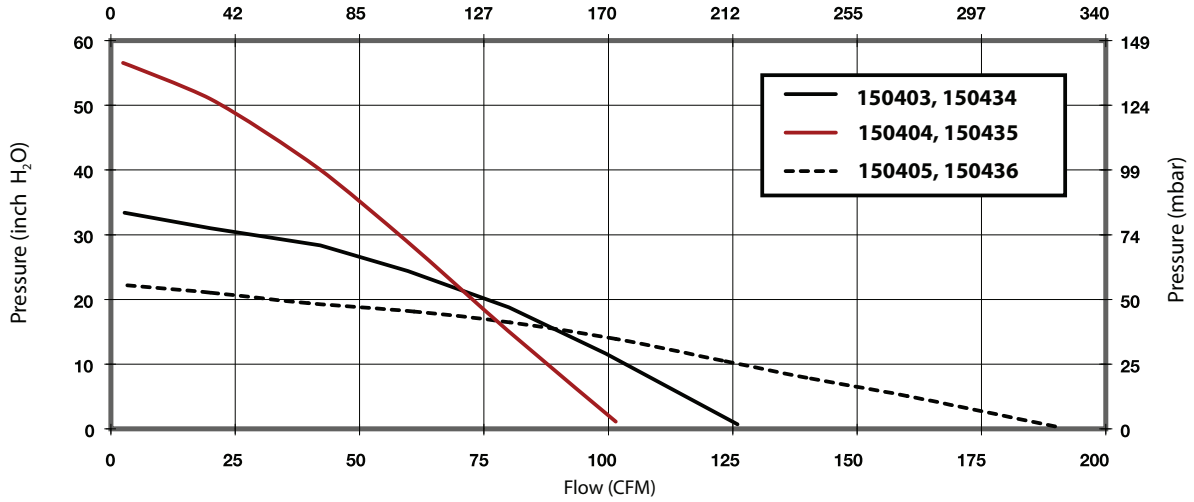

Data presented represents blower performance at STANDARD AIR DENSITY, .075 lb/ft³ (29.92" Hg, Sea Level, 68° F)
Vacuum performance available upon request.

This document is for informational purposes only and should not be considered as a binding description of the products or their performance in all applications. The performance data on this page depicts typical performance under controlled laboratory conditions. AMETEK is not responsible for blowers driven beyond factory specified speed, temperature, pressure, flow or without proper alignment. Actual performance will vary depending on the operating environment and application. AMETEK products are not designed for and should not be used in medical life support applications. AMETEK reserves the right to revise its products without notification. The above characteristics represent standard products. For product designed to meet specific applications, contact AMETEK Dynamic Fluid Solutions Sales department.