

High Voltage Brushless DC Blowers

Nautilair (TM) 7.6" (193mm) Variable Speed Blower

240 Volt AC Input, Single Phase, Standard Output Enhanced

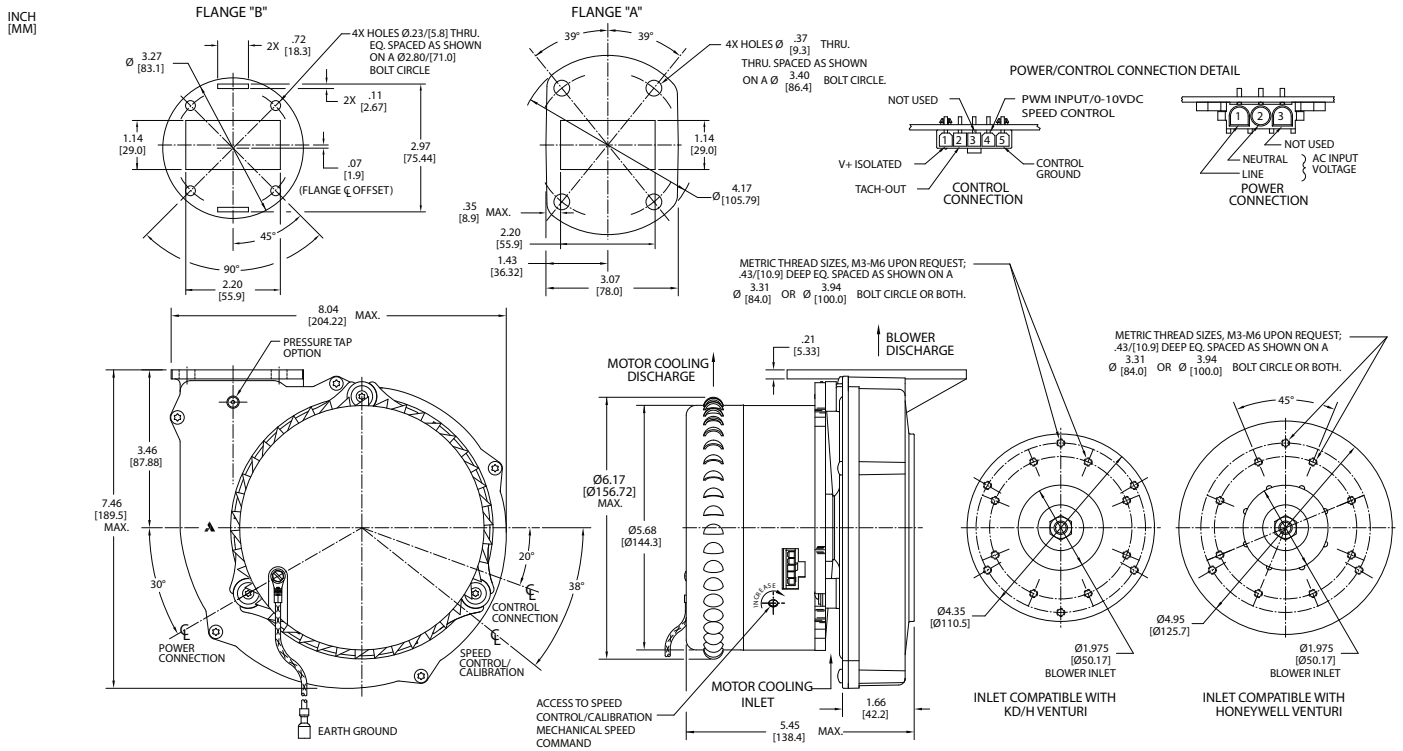

		Part/ Model Number					
Specification	Units	150580	150581	150582	150583	150584	150585
Flange Type	-	Large "A"	Large "A"	Large "A"	Small "B"	Small "B"	Small "B"
Speed Control	-	PWM	0-10 VDC	Mechanical	PWM	0-10 VDC	Mechanical

Notes:

- Input Voltage Range:** 216 - 264 Volts AC RMS, 50/60 Hz, single phase.
- Input Current:** 3 amps AC RMS
- Operating Temperature (Ambient Air and Working Air):** 0°C to 50°C
- Storage Temperature:** -40°C to 85°C
- Dielectric Testing:** 1800 Volts AC RMS 60 Hz applied for one second between input pins and ground, 3mA leakage maximum.
- Speed Control Methods:** PWM (Pulse Width Modulation) (1 kHz to 10 kHz)
0 to 10 VDC speed control.
Mechanical: A potentiometer is available for speed control of the blower. The potentiometer can be preset for a specific speed. Access for speed adjustment located in motor housing.
- Approximate Weight:** 4.8 Lbs. / 2.2 Kg
- Regulatory Agency Certification:** Underwriters Laboratories Inc. UL507 Recognized under File E94403 and compliant under the CE Low Voltage Directive 2006/95/EC.
- Design Features:** Designed to provide variable airflow for low NOx & CO emission in high efficiency gas fired combustion systems. Built with non-sparking materials. Blower housing assembly constructed of die cast aluminum. Impeller constructed from hardened aluminum. Rubber isolation mounts built into blower construction to dampen vibration within the motor. Two piece blower housing assembly sealed with O-ring gasket for combustion applications. Customer is responsible to check for any leakage once the blower is installed into the final application.
- Miscellaneous:** Blower inlet, discharge, and all motor cooling inlet and discharge vents must not be obstructed. Motor ventilation air to be free of oils and other foreign particles, (i.e. breathing quality air). Blower is to be mounted so ventilation air cannot be re-circulated.
POWER CONNECTION: Blower connector, AMP Universal MATE-N-LOK, part no. 1-350943-0.
SPEED CONNECTION: Blower connector, Molex Mini-Fit Jr., part no. 39-30-3056.
Mating harnesses available upon request.

This document is for informational purposes only and should not be considered as a binding description of the products or their performance in all applications. The performance data on this page depicts typical performance under controlled laboratory conditions. AMETEK is not responsible for blowers driven beyond factory specified speed, temperature, pressure, flow or without proper alignment. Actual performance will vary depending on the operating environment and application. AMETEK products are not designed for and should not be used in medical life support applications. AMETEK reserves the right to revise its products without notification. The above characteristics represent standard products. For product designed to meet specific applications, contact AMETEK Dynamic Fluid Solutions Sales department.

High Voltage Brushless DC Blowers

Nautilair (TM) 7.6" (193mm) Variable Speed Blower

240 Volt AC Input, Single Phase, Standard Output Enhanced

Typical Performance

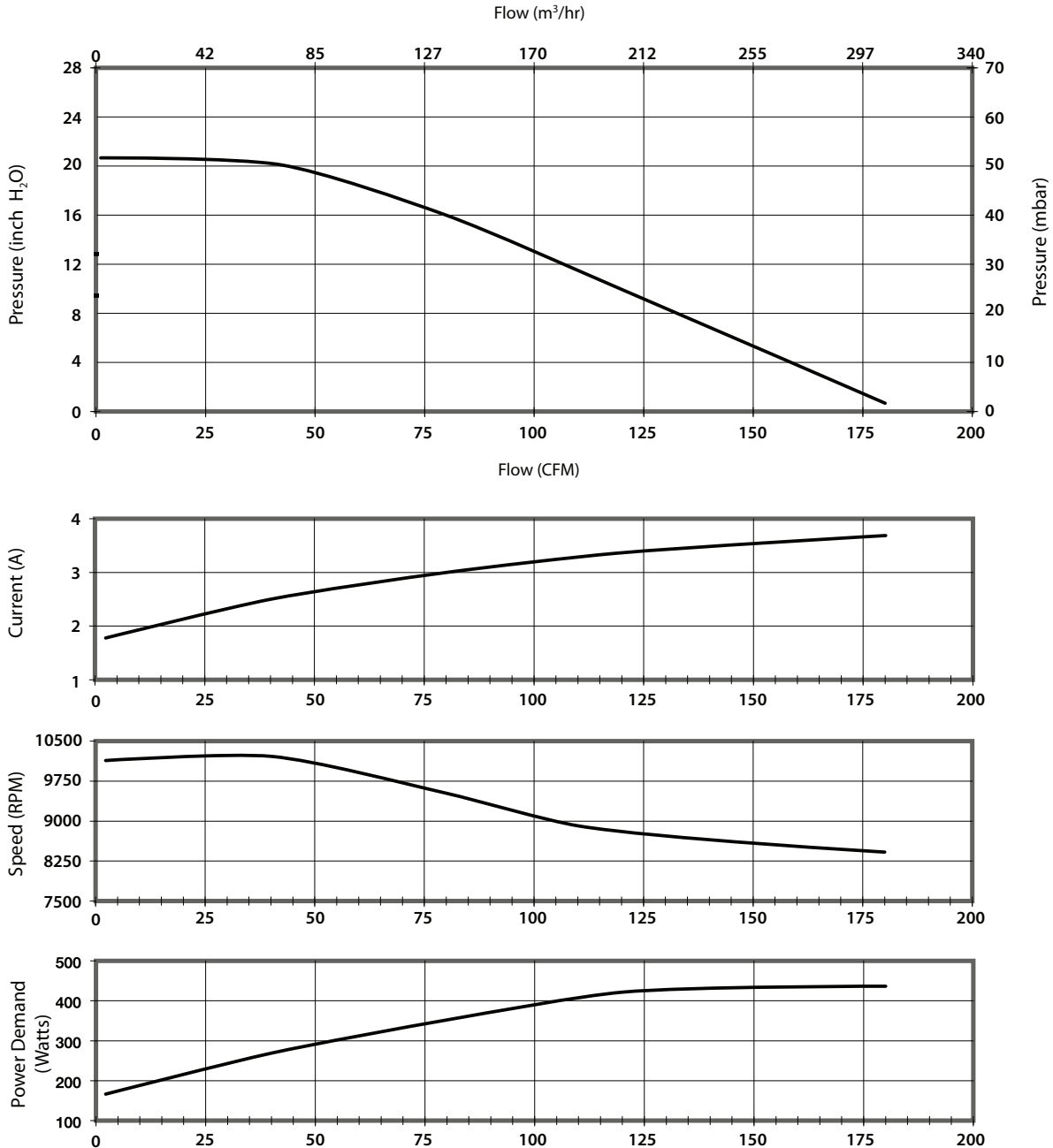

Data presented represents blower performance at STANDARD AIR DENSITY, .075 lb/ft³ (29.92" Hg, Sea Level, 68° F)
 Vacuum performance available upon request.

This document is for informational purposes only and should not be considered as a binding description of the products or their performance in all applications. The performance data on this page depicts typical performance under controlled laboratory conditions. AMETEK is not responsible for blowers driven beyond factory specified speed, temperature, pressure, flow or without proper alignment. Actual performance will vary depending on the operating environment and application. AMETEK products are not designed for and should not be used in medical life support applications. AMETEK reserves the right to revise its products without notification. The above characteristics represent standard products. For product designed to meet specific applications, contact AMETEK Dynamic Fluid Solutions Sales department.