

## Low Voltage Brushless DC Blowers



### 5.0" (127mm) BLDC Low-Voltage Blower

12/24 VDC, Standard Flow System

INCH

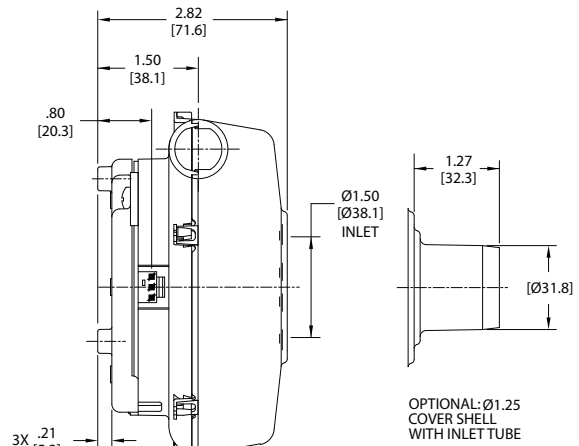
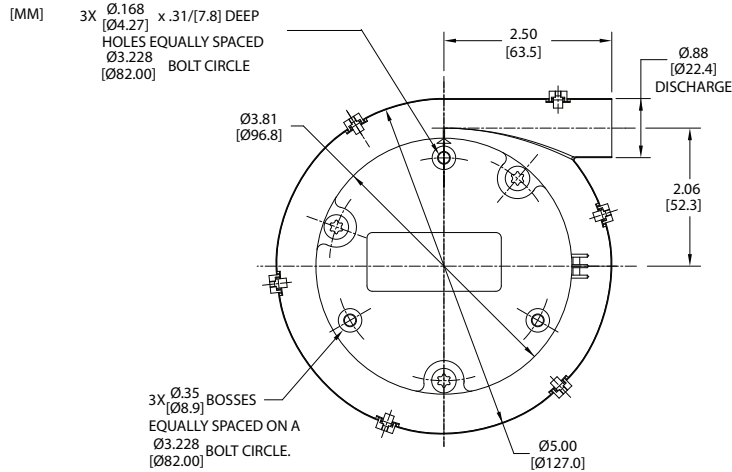

Specification	Units	Part/ Model Number					
		119380	119381	119382	119383	119384	119385
Voltage	VDC	12	12	12	24	24	24
Stages	-	1	1	1	1	1	1
Max. Sealed Pressure	in. H <sub>2</sub> O	13.5	13.5	13.5	12.5	12.5	12.5
	mbar	33.6	33.6	33.6	31.1	31.1	31.1
Max Open Flow Rate	CFM	32.3	32.3	32.3	35.3	35.3	35.3
	m <sup>3</sup> /hr	54.9	54.9	54.9	60	60	60
Speed Control	-	External	Potent. Adjust.	0-4V Spd. Cmd.	External	Potent. Adjust.	0-4V Spd. Cmd.

#### Notes:

- **Temperature:** Working Air: 0°C to 45°C, Ambient Air: 0°C to 45°C, Storage: -40°C to 85°C.
- Customized performance available upon request. Please contact AMETEK Technical & Industrial Products' Marketing and Sales Department.
- When used as a vacuum, the blower performance might be less than shown herein, depending on the operating point.
- Models 119380 thru 119385 can be configured and modified for two (2) plane balance option.
- **Optional** - cover shell with air inlet tube.
- **Weight** = 1.2 lb / .54 Kg

**Potentiometer Adjustment** (Potent. Adjust.) - The specified supply voltage is applied to power the blower and the speed is set by adjusting a potentiometer on the side of the blower.

**0-4V Speed Command** (0-4V Spd. Cmd.) - Blower speed is proportional to a 0-4V command signal. Maximum speed is reached at 4V or less depending on the blower's operating point. The speed command pin may be connected to the blower's 12V or 24V pin to ensure full speed.

**External Control** - Designed to operate with an external controller such as AMETEK's model 48133.

*This document is for informational purposes only and should not be considered as a binding description of the products or their performance in all applications. The performance data on this page depicts typical performance under controlled laboratory conditions. AMETEK is not responsible for blowers driven beyond factory specified speed, temperature, pressure, flow or without proper alignment. Actual performance will vary depending on the operating environment and application. AMETEK products are not designed for and should not be used in medical life support applications. AMETEK reserves the right to revise its products without notification. The above characteristics represent standard products. For product designed to meet specific applications, contact AMETEK Dynamic Fluid Solutions Sales department.*



Typical Performance

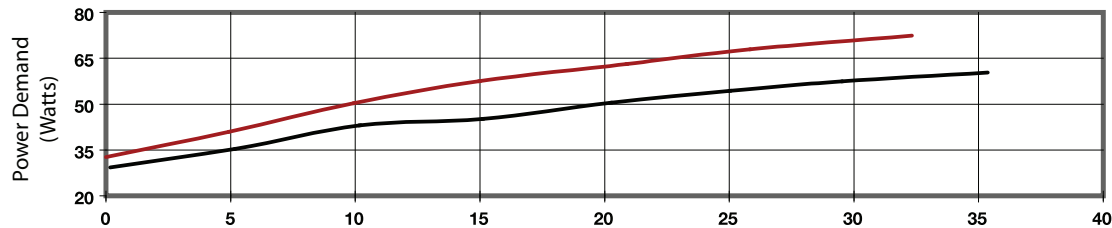
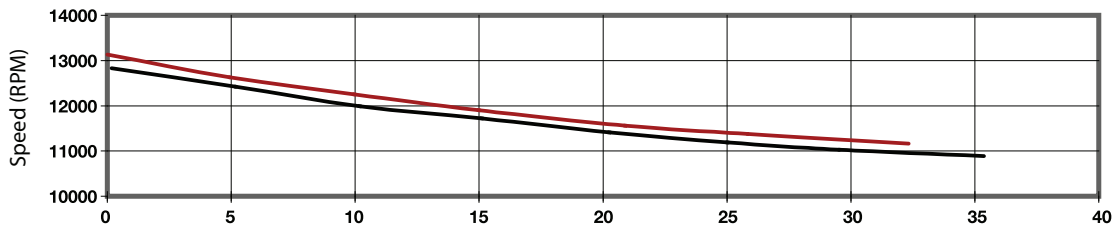
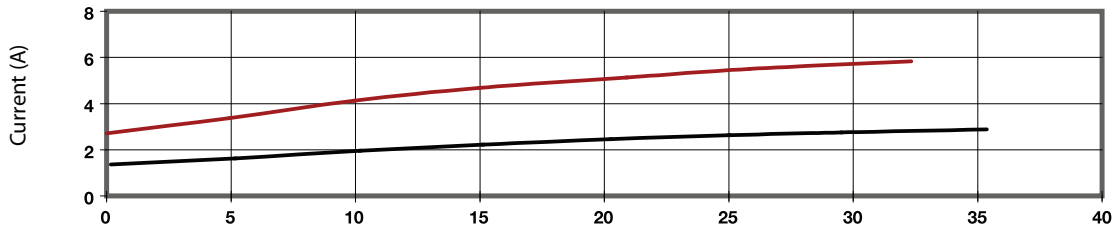
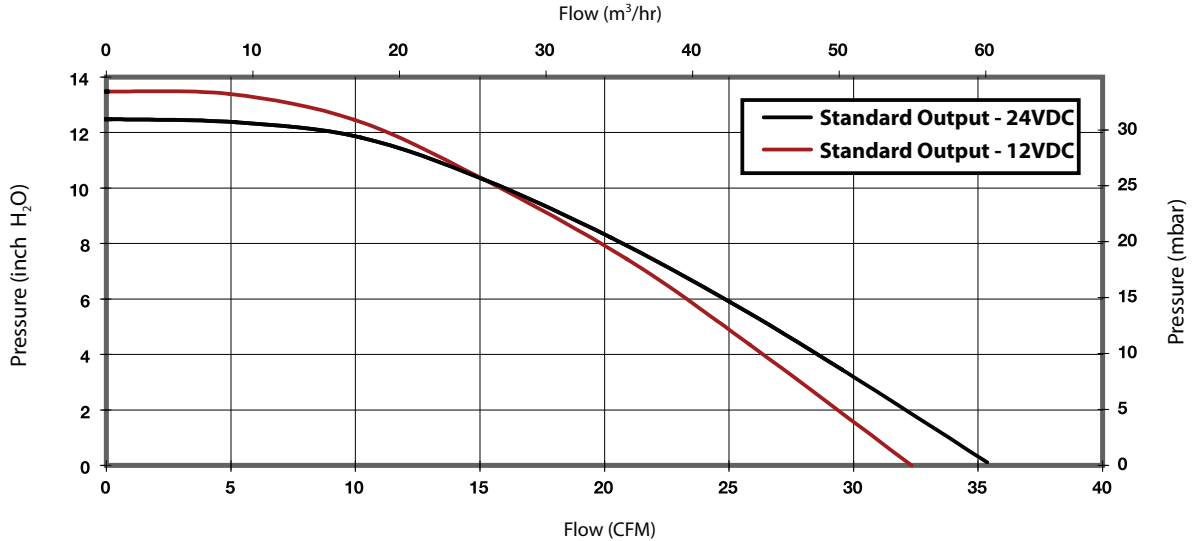

Data presented represents blower performance at STANDARD AIR DENSITY, .075 lb/ft<sup>3</sup> (29.92" Hg, Sea Level, 68° F)  
 Vacuum performance available upon request.

*This document is for informational purposes only and should not be considered as a binding description of the products or their performance in all applications. The performance data on this page depicts typical performance under controlled laboratory conditions. AMETEK is not responsible for blowers driven beyond factory specified speed, temperature, pressure, flow or without proper alignment. Actual performance will vary depending on the operating environment and application. AMETEK products are not designed for and should not be used in medical life support applications. AMETEK reserves the right to revise its products without notification. The above characteristics represent standard products. For product designed to meet specific applications, contact AMETEK Dynamic Fluid Solutions Sales department.*