

PROJECT: _____	UNIT TAG: _____	QUANTITY: _____
REPRESENTATIVE: _____	TYPE OF SERVICE: _____	DATE: _____
ENGINEER: _____	SUBMITTED BY: _____	DATE: _____
CONTRACTOR: _____	APPROVED BY: _____	DATE: _____
	ORDER NO.: _____	DATE: _____



CR 5-12 A-FGJ-A-E-HQQE

Vertical, multistage centrifugal pump with suction and discharge ports on the same level. The pump head and base are in cast iron - all other wetted parts are in stainless steel (EN 1.4301)

Note! Product picture may differ from actual product

Conditions of Service		Pump Data		Motor Data	
Liquid:	Water	Max pressure at stated temp:	363 psi / 250 °F	Rated power - P2:	5 HP
Temperature:	68 °F	Liquid temperature range:	-4 .. 248 °F	Rated voltage:	230/460 V
Specific Gravity:	1.000	Maximum ambient temperature:	104 °F	Mains frequency:	60 Hz
		Shaft seal:	HQQE	Enclosure class:	IP55
		Product number:	99916790	Insulation class:	F
				Motor protection:	NONE
				Motor type:	WEG
				Eta 1/1:	88.5 %

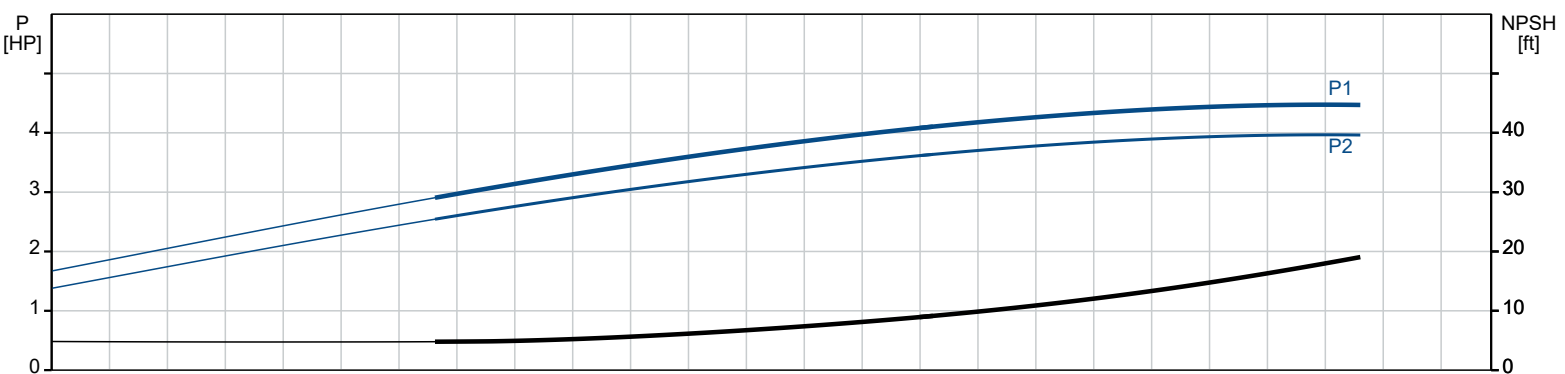
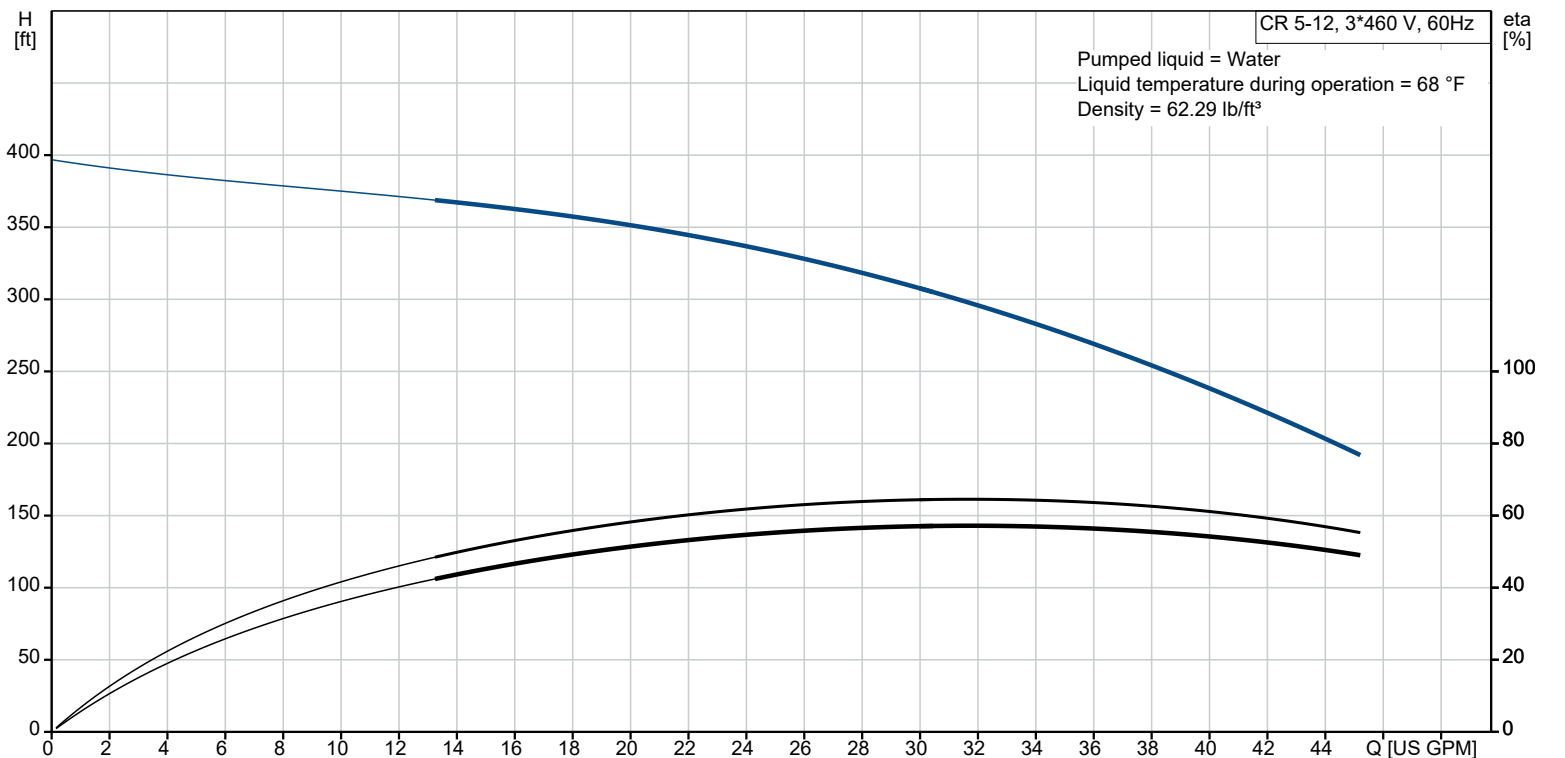

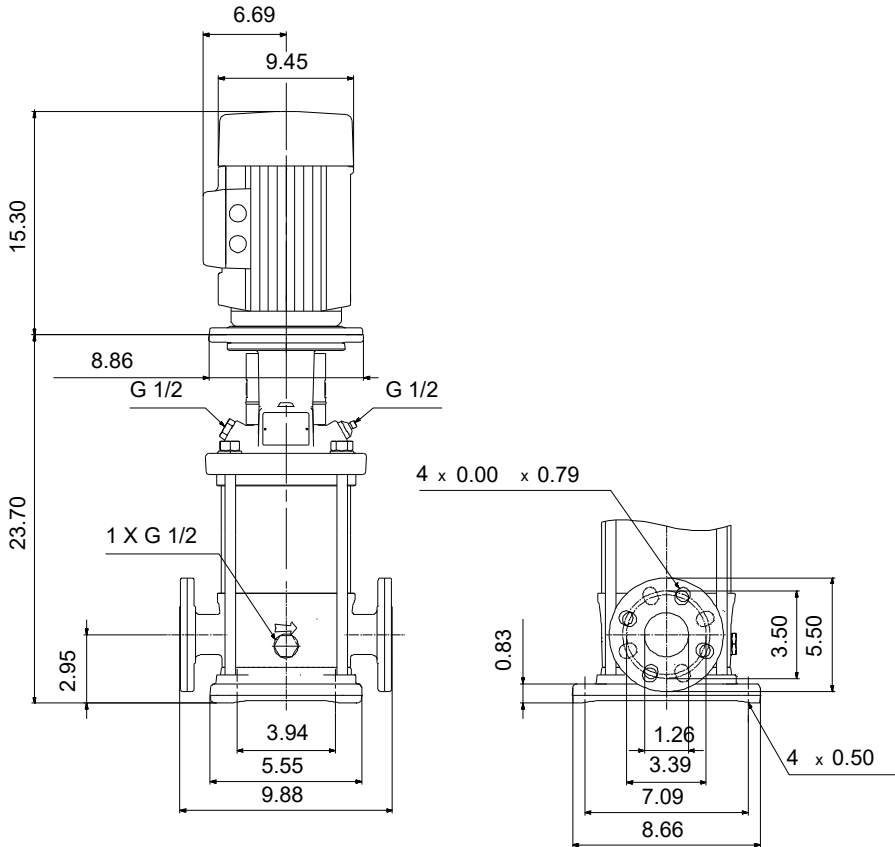

Materials:

Base: Cast iron
 Base: EN 1561 EN-GJL-200
 Base: ASTM A48-25B
 Impeller: Stainless steel
 Impeller: AISI 304
 Impeller: EN 1.4301
 Material code: A
 Code for rubber: E



Company name: Optimal

Created by:

Phone:

Date:

21/07/2023

99916790 CR 5-12 A-FGJ-A-E-HQQE 60 Hz

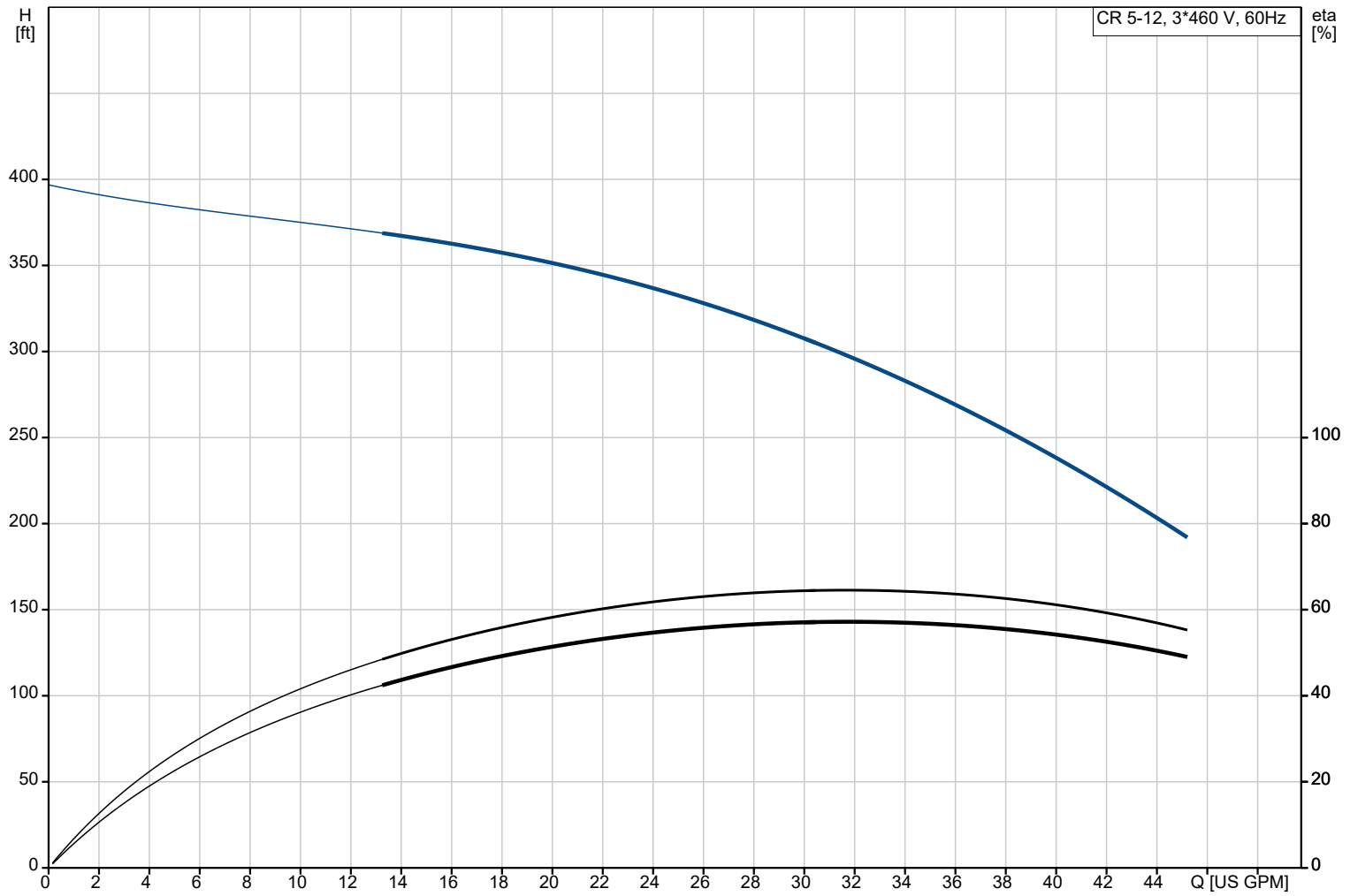

Pumped liquid = Water
Liquid temperature during operation = 68 °F
Density = 62.29 lb/ft³

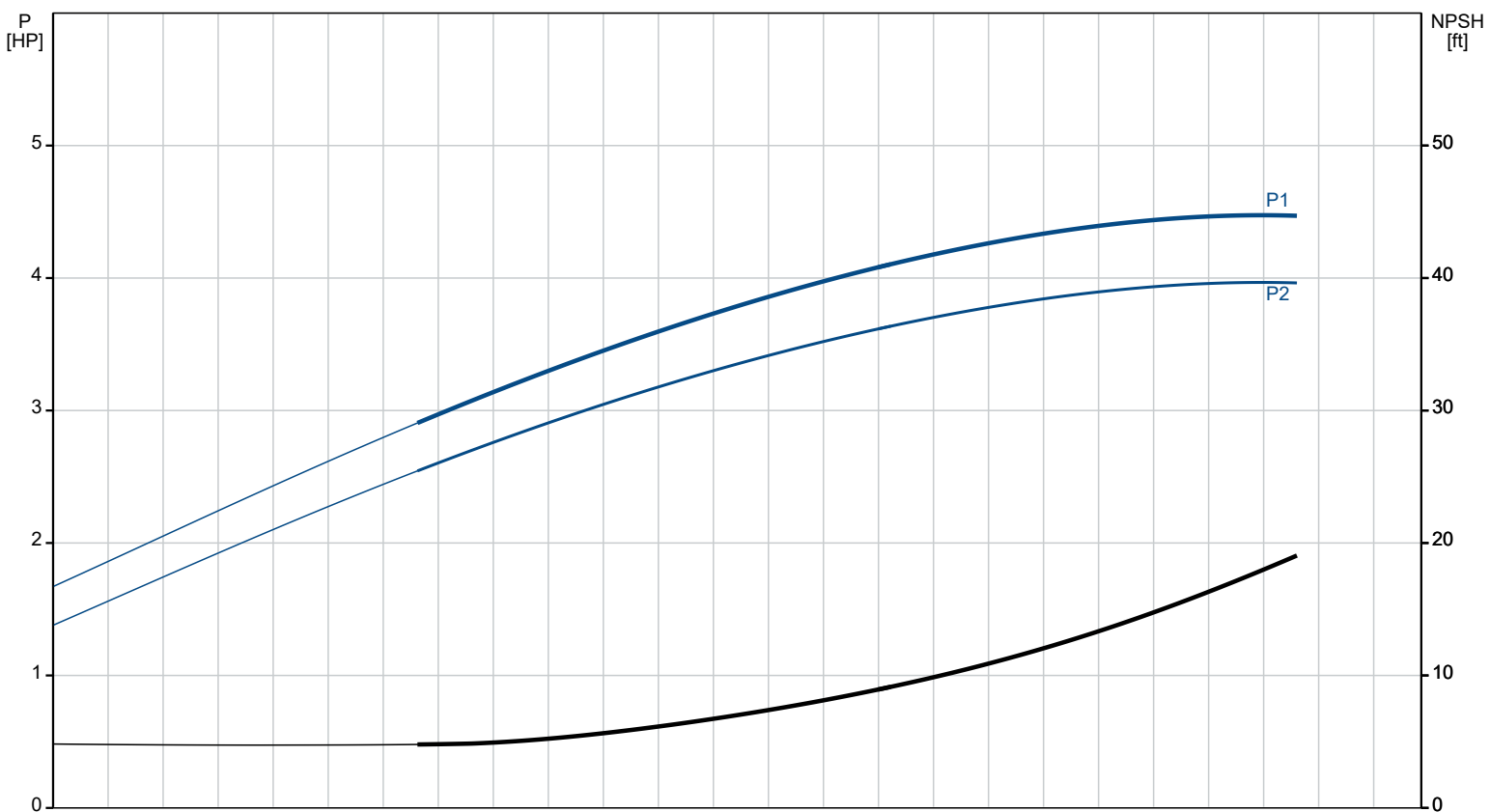

Description	Value
General information:	
Product name:	CR 5-12 A-FGJ-A-E-HQQE
Product No:	99916790
EAN number:	5715114115599
Technical:	
Pump speed on which pump data are based:	3461 rpm
Rated flow:	30.4 US GPM
Rated head:	291.7 ft
Maximum head:	391.8 ft
Stages:	12
Impellers:	12
Number of reduced-diameter impellers:	0
Low NPSH:	N
Pump orientation:	Vertical
Shaft seal arrangement:	Single
Code for shaft seal:	HQQE
Approvals:	CURUS
Approvals for drinking water:	NSF/ANSI 61
Curve tolerance:	ISO9906:2012 3B
Pump version:	A
Model:	A
Cooling:	IC 411
Materials:	
Base:	Cast iron
Base:	EN 1561 EN-GJL-200
Base:	ASTM A48-25B
Impeller:	Stainless steel
Impeller:	EN 1.4301
Impeller:	AISI 304
Material code:	A
Code for rubber:	E
Bearing:	SIC
Installation:	
Maximum ambient temperature:	104 °F
Maximum operating pressure:	362.59 psi
Max pressure at stated temp:	363 psi / 250 °F
Max pressure at stated temp:	363 psi / -4 °F
Type of connection:	DIN / ANSI / JIS
Size of inlet connection:	DN 25/32
Size of outlet connection:	DN 25/32
Pressure rating for connection:	PN 25
Flange rating inlet:	250 lb
Flange size for motor:	182TC
Connect code:	FGJ
Liquid:	
Pumped liquid:	Water
Liquid temperature range:	-4 .. 248 °F
Selected liquid temperature:	68 °F
Density:	62.29 lb/ft ³
Electrical data:	
Motor standard:	NEMA
Motor type:	WEG
Rated power - P2:	5 HP
Power (P2) required by pump:	5 HP
Mains frequency:	60 Hz
Rated voltage:	3 x 230/460 V
Service factor:	1.15
Rated current:	11.8/5.9 A
Starting current:	780 %
Full load SF current:	13.6/6.79 A
Cos phi - power factor:	0.89
Rated speed:	3500 rpm
IE efficiency:	IE3 88,5%
IE Efficiency class:	IE3 / NEMA Premium
Motor efficiency at full load:	88.5 %

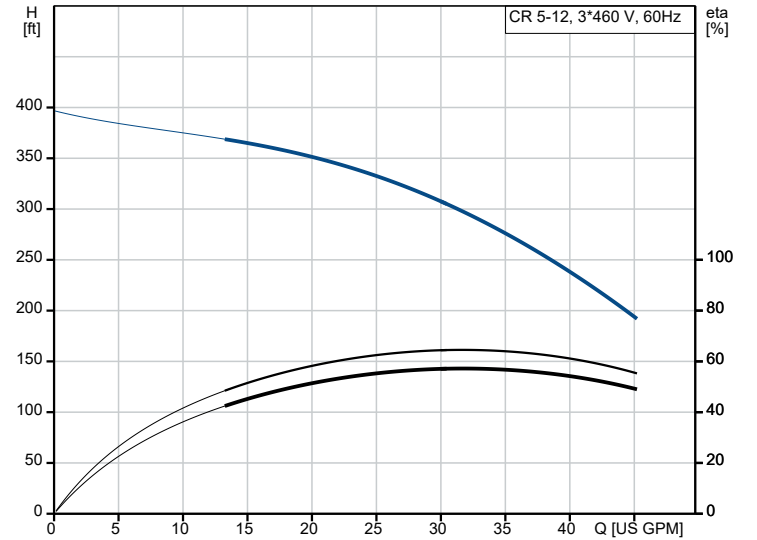

Pumped liquid = Water
 Liquid temperature during operation = 68 °F
 Density = 62.29 lb/ft³

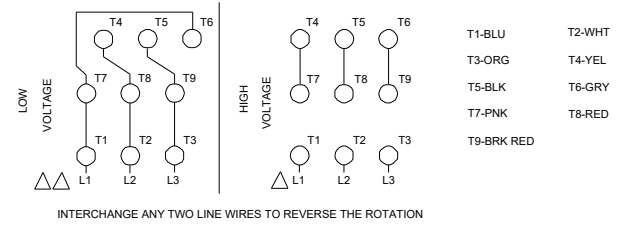
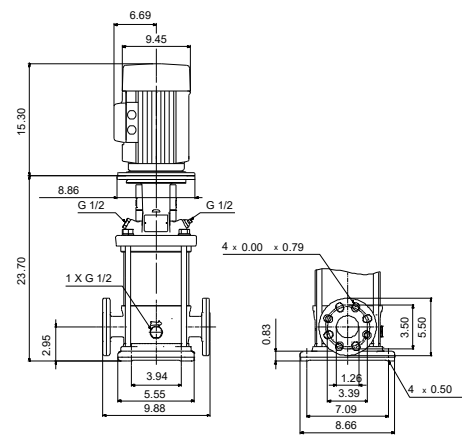
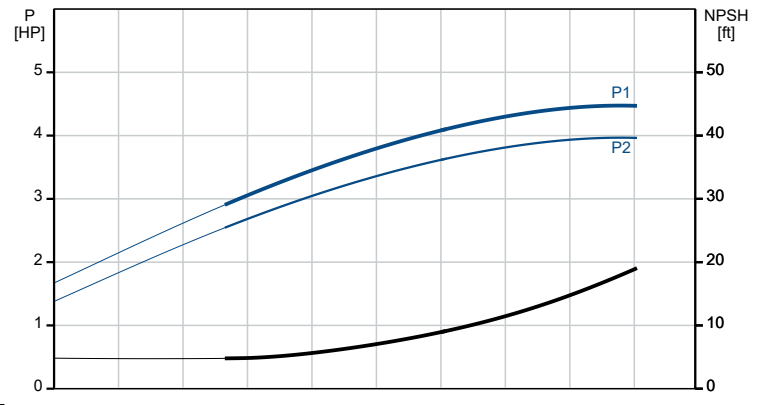



Company name: Optimal

Created by:

Phone:

Date:

21/07/2023

Description	Value
Motor efficiency at 3/4 load:	88.5 %
Motor efficiency at 1/2 load:	87.5 %
Number of poles:	2
Enclosure class (IEC 34-5):	IP55
Insulation class (IEC 85):	F
Built-in motor protection:	NONE
Motor No:	99882380
Controls:	
Frequency converter:	NONE
Others:	
Net weight:	148 lb
Gross weight:	166 lb
Shipping volume:	10.1 ft ³

99916790 CR 5-12 A-FGJ-A-E-HQQE 60 Hz

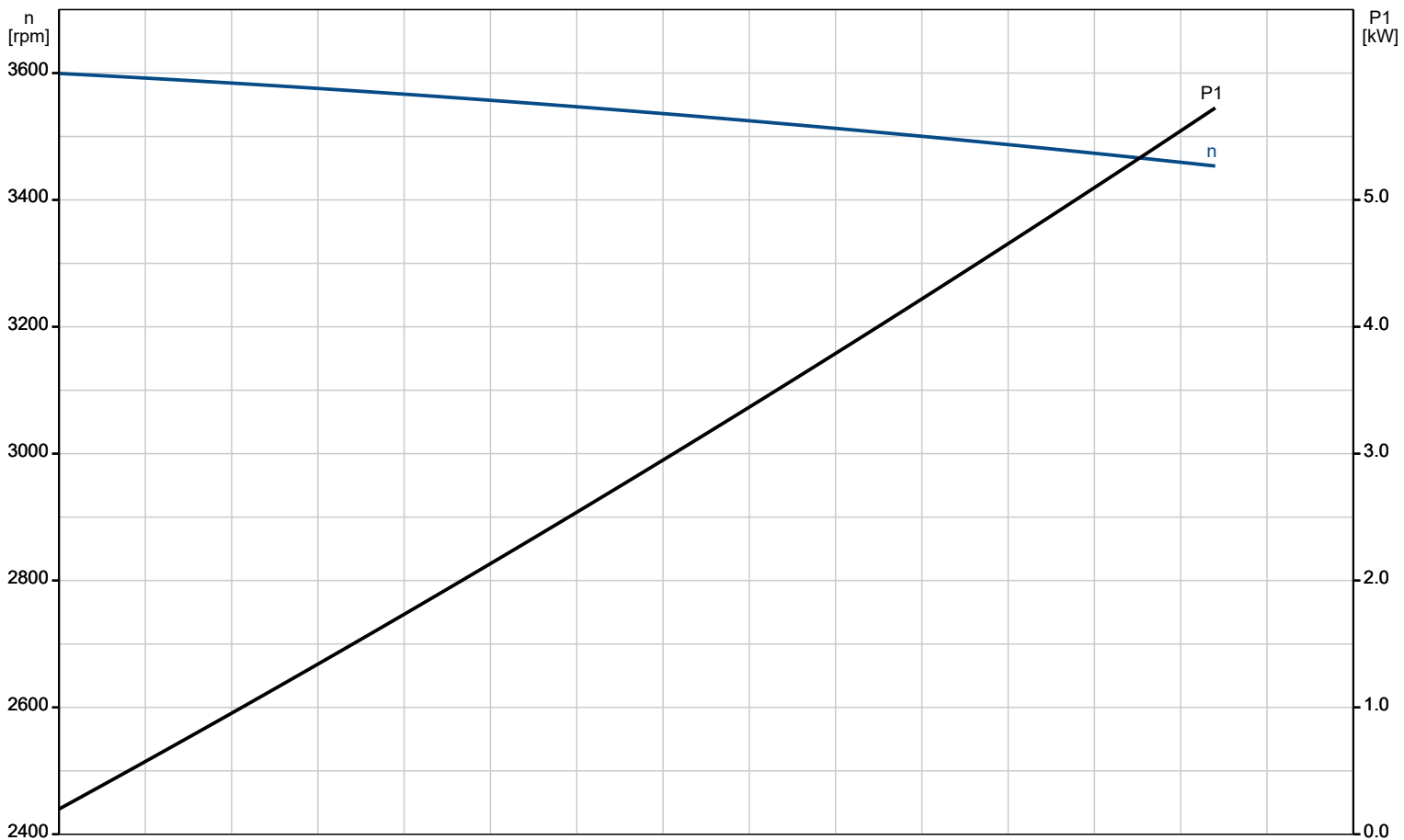
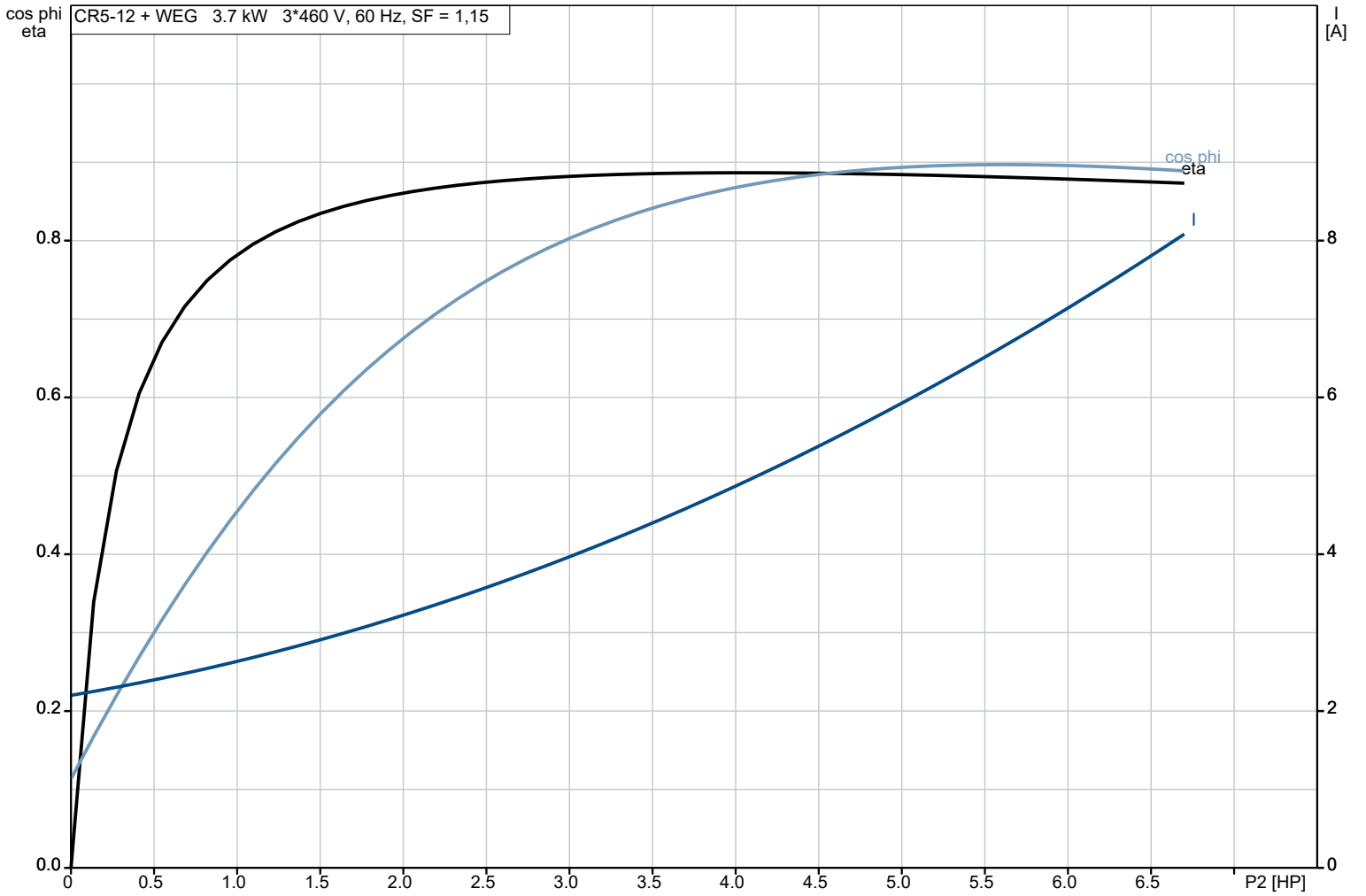

99916790 CR 5-12 A-FGJ-A-E-HQQE 60 Hz

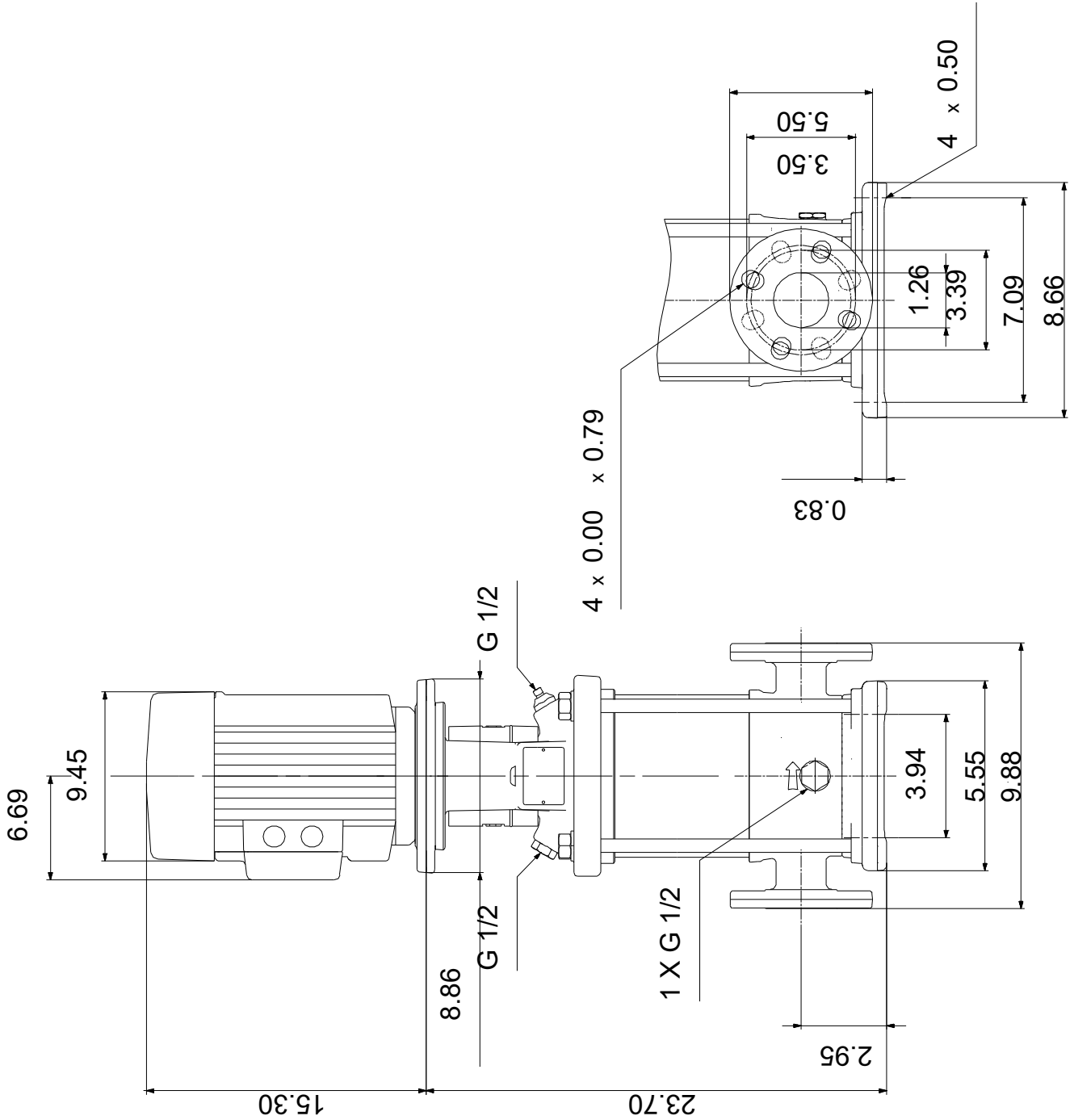

99916790 CR 5-12 A-FGJ-A-E-HQQE 60 Hz

- | | |
|--------|------------|
| T2-WHT | T1-BLU |
| T4-YEL | T3-ORG |
| T6-GRY | T5-BLK |
| T8-RED | T7-PNK |
| | T9-BRK RED |

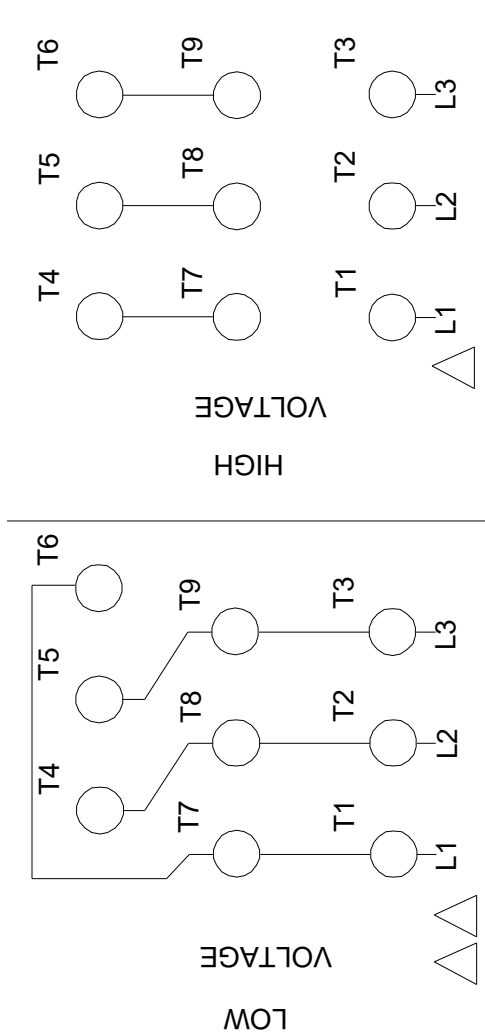

Note! All units are in [in] unless others are stated.