

**RAINHART**<sup>TM</sup>  
AN INSTROTEK COMPANY

# The Original **Mary Ann**<sup>®</sup> Laboratory Sifter



**INSTRUCTIONAL BOOKLET**



# The Original **Mary Ann**<sup>®</sup> Laboratory Sifter

## INSTRUCTIONAL BOOKLET

Cat. No. 637D Combination of 12 and 8 inch  
With Digital Timer



**Note:** for first time operation (or if the power has been interrupted, either by unplugging the sifter or a power outage), press the emergency stop button in; connect the power, then press the "Relay Reset" button in the top panel inside the cabinet. The sifter should operate normally.

This combination model Rainhart Laboratory Sifter efficiently reproduces hand sieving. Rapid production, quiet operation, low sieve wear and freedom from inconvenient clamping, are her unique features. This patented system is extremely gentle.

Capacity: pan, six 12" dia. x 3-in. high or ten 8" dia. x 2-in. high standard laboratory sieves and covers. (If interested only in 8-in. sieving, see Cat. No. 635)

Floor stand of aluminum tubing with rubber feet has horizontal 22-in. long rails for sieve storage. The case revolves from 45° to near vertical to allow convenient vertical loading of a heavy stack of sieves and for easy cleaning. Floor space: 18 x 40-in. 1/3 hp 115VAC 60HZ ball bearing motor drives two rubber covered trunions and 10 hammers with hardwood heads. An idler roller stabilizes 12-in. sieves. Special power requirements can be met.

The cabinet is fitted with aluminum control panel and timer/switch. Sound suppressing lid is shipped unattached to avoid damage and is easily hinged on either side (or omitted) and swings 3/4 turn to hang vertically. All shaft bearings are maintenance-free sealed ball pillow blocks.

To convert from 8 to 12-in. operation, the turntable is inserted in the correct pillow block and the hammer spring tension is adjusted with a flip of a lever on the control panel.

**Cat. No. 637 Laboratory Sifter, 12 & 8-in. Model:** (less sieves) complete with 15 min. timer/switch and Laboratory Sifter Booklet; will sieve up to 26-in. stack of unclamped 12 or 8-in. dia. laboratory sieves at 45°. Approx. Ship. Wt. 135 lb.

# Mary Ann

During development, when the prototype was returned from field evaluation with excellent comparison data, we were delighted to find that the lab technician had affectionately written “Mary Ann” across the control panel. Mary Ann, according to a Calypso ballad, spent all her time “down by the seashore, sifting sand.” Thus was she christened.

## Principle of operation

The inclined, rotating stack of sieves provides a gentle, thorough, agitated, tumbling action, which exposes the climbing particles to a vast multiplicity of chances and angles to pass through the mesh. Gravity keeps the material bearing on the progressively changing rotating mesh which either passes the particles or carries them up the incline to tumble back with the nesting particles pouring out of the apertures and down into the percolating pile. This process is repeated again on the next below smaller meshed sieve—and so on down through the stack. Sifting is extremely rapid and thorough.

The uphill action is sifting; downhill is cleaning. A mixture of material of widely varying specific gravities will be sifted without problems.

The fixed angle of the stack is critical—

- A more vertical angle will cause the material to nest in the mesh and block the apertures;
- A more horizontal angle will prevent the material from being carried up by the sieve and hence from sifting.

Tapping action is provided at right angles to the sieves. This encourages the lighter and finer near-mesh materials to clear the apertures allowing a larger specimen to be sorted. The hammers are cocked by a cam and cam-follower and then triggered; a spring throws them upward to tap the frames of the sieves at right angles to the axis. Their normal at-rest position is well below the sieve frames to give the hammers room to retreat after striking.

## Degradation of Material

Do not expect this gentle sifter to disintegrate even small lumps of dry clay—Mary Ann is not that kind of a girl! Material degradation, sieve abrasion and particle jamming are not her vices. Dry clay lumps must be pulverized before sifting to avoid being classified by their lump sizes.

## About Sifting

Sifting with laboratory sieves is the standard method for classifying granular materials in a cohesionless state by particle size. After the end point is reached, the material retained by each mesh in a series of designated progressive sizes is weighed and tabulated as a percentage of the total sample; this data is often plotted into a convenient curve which displays the particle size distribution.

### Nomenclature

- **Retained** particles are those which have passed through all the larger mesh sizes and have accumulated on each size of mesh; these materials are assumed to be free of all pass particles and will be weighed and recorded in the blank labeled with the sieve’s mesh size; and
- **Pass** particles are all the smaller unclassified sizes which could escape through the designated mesh. To go one step further, all particles that are retained can be classified into—
- **Bulk** particles which are so large that they have no tendency to mate with the sieve; and
- **Near-mesh** or **near-size** particles. These are so close to the mesh size that they will engage in the screen wire and blind the apertures until the sieve is cleaned.
- **Blind** is used to refer to a sieve that has been blocked by near-mesh particles. Near-mesh particles can be further subdivided into—
- **Nested** particles, which will blind a sieve by engaging in the mesh but have little

tendency to jam and require only non-destructive manipulation to be removed by canting at a steep angle or inverting.

- **Lodged** particles are those which require mild assistance in cleaning such as using bare fingers, conventional sieve brush action, rapping the rim with a hardwood brush handle, etc. and
- **Jammed** are stubborn particles, which require drastic or potentially destructive methods to dislodge such as by applying high pressure with a metal probe—never a recommended practice!

**Note:** How easily these particles are dislodged is the important difference between nested vs. lodged vs. jammed particles and is of major importance when evaluating sifting equipment. Jammed particles are nested particles that have been driven home by high amplitude vibration generally associated with violent impact or with drumhead excited sieve wire. In general, the more violent the apparatus, the worse the jamming! One characteristic of the gentle Rainhart Laboratory Sifter is its canted self-cleaning action which pours the nested particles back into the percolating pile; fewer of the nested particles are lodged and therefore the sieves are more quickly and easily cleaned and suffer less damage. Larger lodged particles can generally be removed with bare fingers and a few taps on the rim. A few strokes across the bottom with the sieve brush will generally suffice with the finer mesh.

- **Overloaded sieve**—regardless of the quantity of material—is one whose mesh becomes blind with near-mesh particles; further passage will be drastically curtailed and will invalidate the results of this and all smaller sizes. (This situation is true for both the hand method and for all mechanical “sieve shakers” regardless of the type or make of the apparatus).
- **Stack** of sieves. In mechanical sieving, the sieve family is arranged starting with the pan on the bottom; the finest through the coarsest, by mesh size, are superimposed into a stack.
- **Pan** is the receptacle at the bottom of the stack; it accumulates the pass particles from the smallest

mesh sieve. The pan is engaged with the sieve above by the conventional friction flange arrangement. The material accumulated in the pan is called “pan” and is weighed and recorded on the report form in the space labeled “pan.”

- **Pan with extended rim** (for example, our 8-inch diameter Cat. No. SSP-8-2), which engages the friction flanges of the adjacent sieves above and below, can be inserted anywhere within a stack and is used to accumulate the pass materials from any particular sieve (often used when checking the endpoint; it will also allow two short stack of sieves to be run simultaneously).
- **End-point.** Since perfect sifting is impossible, an arbitrary end-point must be a compromise between practicality and significance. A survey of procedures yielded—

ASTM Designation D 422: “When mechanical sieving is used, test the thoroughness of sieving by using the hand method of sieving as described above...”

AASHTO Designation T 88-57: “When sieving machines are used, their thoroughness of sieving shall be tested by comparison with hand methods of sieving as above described...”

AASHTO Designation T 27-60: “When mechanical sieving is used the thoroughness of sieving as described above...”

Bur. Of Rec. Designation E-4: “Item 85, 1 ea., sieve shaker, motor-driven, electric or gasoline equipped with timer...”

ASTM Designation C 136: “...after completion, not more than 1 per cent by weight of the residue on any individual sieve will pass that sieve during 1 min. of continuous hand sieving performed as follows: Hold...”

### Guidelines

Once the idiosyncrasies of a specific material are established, many shortcuts can be practiced for routine sifting. Whether by hand or machine the following hints may assist accurate or preliminary grading—

**1) Sieve quality.** A defective sieve will invalidate this and all finer gradations! Carefully examine each sieve visually for oversize holes; if not too numerous, these can be permanently closed with soft solder. Jammed particles affect only the rate and capacity of the sieve by reducing the area. Inspect sieves of #50 and finer for snags and tears and for broken (fatigued) wire around the edge at the solder joint; this is a commonly overlooked failure point. Press the mesh with the fingertips progressively around the rim to make sure that there is no concealed by-pass!

**2) Make sure the end-point has been achieved.**

Since sifting may not have been completed and since finer materials may still be trapped in a blind sieve, it is imperative that the completion of each and every gradient be proved. Mechanically sift the sample for four or five minutes. Starting the largest size and successively prove that each sieve is not blind and that the endpoint has been reached.

**3) Inspection.** Hand sieve a few strokes over a clean receptacle to discover if the end-point has been apparently reached. Then test for blindness. First, hold the sieve overhead and examine the bottom for hanging nested particles. Wedge-shaped particles (which are merely nested) are particularly adept at blinding sieves. If these specimens have been run in a Rainhart Laboratory Sifter, tilt the sieve to its normal angle of approximately 45° and rotate it to and fro about its axis so that the bulk materials will flow away leaving on the nested materials displayed for inspection across the top of the mesh.

**4) Quarantining near-mesh.** If an occasional sieve is extensively blinded, carefully pour off the bulk material into a clean “holding” receptacle slowly and gently to encourage as many near-mesh particles as possible to cling. Unfortunately, most of the nested particles will be poured off with the bulk materials. Clean the sieve into a second clean receptacle to isolate and quarantine as many of the near-mesh particles as possible. These particles have already been proved as retained and will be recombined at weighing.

**5) Repeat sifting if necessary.** If the end-point has not been reached, transfer the material in the hold-

ing receptacle back into the cleaned sieve for additional sifting. Since many of the troublemakers were quarantined from the batch, the sieve will remain open longer. After sifting, repeat the inspection and again quarantine the lodged and jammed particles by cleaning into the quarantined material. Repeat as many times as necessary to arrive at the end point. (It is customary not to disturb the most tenacious particles—particularly in the very fine meshes—for fear of damaging the sieve).

**6) Unloading a sieve.** If a material is very heavy in a single size or has a serious nesting problem, a smaller specimen may have to be used (half-size by weight, for example) or an uncalled for slightly larger mesh size can be introduced in the stack to help unload this sieve. Any material retained on the additional size can be combined with that retained on the desired size since it has satisfied the conditions of passing all of the above larger sieves and would have been retained by any smaller mesh. Example—Sieves #4 and #8 are specified and #8 is overloaded. Introduce a #5 or #6 in the stack and combine its material with the #8 at weighing.

**7) End-point.** The most careful particle size analyzation is accomplished by sifting any questionable sieve size into its own pan (or pan with extended rim). The amount of material that passed this sieve and was collected in the pan will indicate the approach to—or the proof that—the end-point has been reached. This material can then be combined with the bulk material in the next smaller sieve. All of the end-points assume that the sieve is not blind.

**8) Weighing.** When the end-point is reached, weigh the combined retained, quarantined and near-mesh particles.

**9) Odd shaped apertures.** Laboratory sieves are constructed of square woven wire mounted in round frames; this produces border interstices that are neither square nor standard.

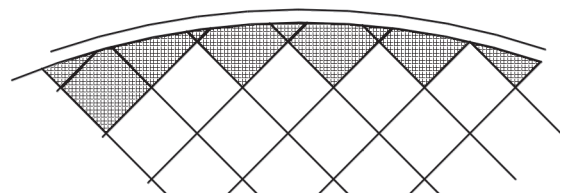

The larger the mesh size, the more ridiculous this becomes. Particles which should have passed—particularly when they are wedge-shaped or are long slivers—will be retained in these off-square apertures and are the most troublesome to remove when cleaning. It is unfortunate that current principal testing procedures are silent on this point other than to recommend using the larger diameter sizes when grading larger size aggregates (Rainhart Cat. No. 637D also accommodates 12-inch diameter sieves).

## Assembly 637D

- 1) Carefully unpack the sifter, stand and door.
- 2) To attach the stand to the cabinet, lay the cabinet down on its back and slide the stand over the cabinet between the stops on the quadrants and align with the cabinet's pivots. The stand is symmetrical.

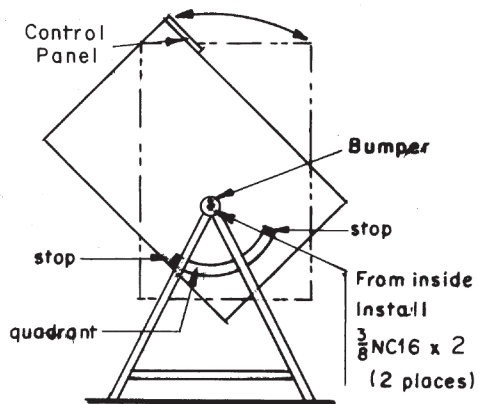

- 3) Install the two 3/8-in. dia. Capscrews from the inside of the cabinet by screwing them into the pivots at the top of the stand.

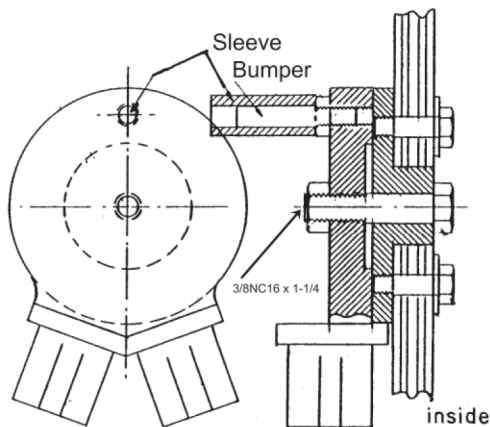

- 4) Adjust the bolt tension to eliminate play but allow the cabinet to pivot freely between the quadrants' end stops. Install and tighten the lock nuts.

- 5) Attach the Door (the door has been packed separately because pre-hinged doors have been damaged in shipment). It can be hinged to open either left or right. Insert the pin into the control panel's ear, align with the open top of the case and install the lower hinge plate. A rubber-covered door stop is installed to prevent the open cover from being damaged when open.

- 6) With two people, lift the cabinet and stand to upright position.

### Turntable

Install the turntable by inserting its stem into the lower bearing in the footboard for 8-in. and into the upper bearing for 12-in. sieves—concentric with the stack of sieves.

### Lever on the Control Panel

Turn the lever on the control panel right to "8" for 8-in. sieves and left to "12" for 12-in. sieves. This puts a second spring into play to increase the force of the clappers when using the heavier sieves.

### Tilt

The cabinet is pivoted to near vertical for loading. It is gravity restrained in either the vertical or its 45° position against the end stops of the quadrants in contact with the stand.

### Nesting the sieves

Place the pan on a table. Stack the sieves from finest to coarsest in sequence nesting one on top of the other. Any number of sieves or stacks of sieves (if divided with a sieve separator pan with extended rim nesting skirt) can be run simultaneously up to the capacity of the apparatus.

### Sample size

Try a sample of up to 10 lb. When using 12-in. sieves and up to 5 lb. using 8-in. Adjust from there. The type and grading will dictate optimum size, see About Sifting, above. Pour the sample into the top of the stack and install the lid.

### Installing the stack

Lift the stack of sieves vertically and place it on the turntable and against the rollers. Tilt the cabinet to its 45° angle against the quadrant's stops.

**ATTENTION:** the "emergency" push button on the control panel should be left in the off (pushed in) position when the sifter is not in use!

**Note:** for first time operation (or if the power has been interrupted, either by unplugging the sifter or a power outage), **press the emergency stop button in;** connect the power, then press the "Relay Reset" button in the top panel inside the cabinet. The sifter should operate normally.

**Power** 115VAC 60Hz. (Unless special order)  
Plug the cord into a convenient receptacle.

### Starting the sifter

1) Push the red emergency stop button in to turn the sifter power off. The emergency button is on the right hand side of the control panel.

2) Press the RESET button on the timer.

3) If the sifting time displayed on the timer is not the time desired, Program the timer for the desired sifting time. See "Programming the timer" below.

4) Twist the red emergency stop button clockwise to start the sifting process.

To pause the sifting cycle, push the emergency stop button in. The sifting cycle will stop and the timer will hold the time remaining. To resume the interrupted cycle, twist the red emergency stop button clockwise and the sifting cycle will finish its program.

To stop the sifting cycle before the program is complete, push the emergency stop button in and press the RESET button on the timer. The timer will reset to the previous program and is now ready to begin the next cycle.

To repeat the same program, press the RESET button. The timer will reset and the sifter will immediately start sifting.

### Programming the timer

5) Push the red emergency stop button in.

6) Press the PROGRAM button on the timer to enter the program mode. The timer will automatically exit the program mode after approximately 10 seconds of inactivity.

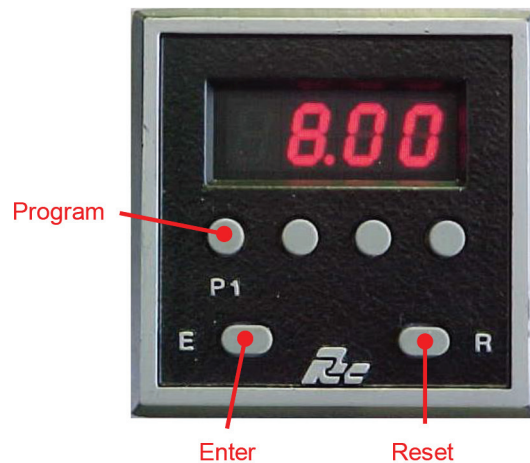

7) The current program will be displayed.

8) Press the button below each digit until the desired program is set. The timer is programmable from 1 second to 99 minutes and 59 seconds.

For example: 12.30 will run twelve minutes and thirty seconds.

9) Press enter to complete the programming cycle and then reset to set the timer to the new program.

### Remove the stack

Tilt the cabinet to near vertical. Open the door. Lift the stack and place it vertically on the bench.

Remove the stack's lid and set it aside. Remove the sieves one at a time and pour their contents into individual containers; weigh and record. (Verify the end-point if not confident as described in About Sifting, above).

### To clean the cabinet

With the cabinet empty of sieves and vertical, brush any dust out the front into a catcher pan.

The dust is generally particles that have escaped through the closely fitting joints

between sieves and can therefore usually be added to "pan."

### Sieve storage

The two parallel horizontal tubes in the stand will hold a stack of nested extra sieves; these are accessible from either side.

### Rims of sieves

There are no rigid specifications on the exact height of sieve rims or on the diameter of the external rolled bead; hence the exact height, location and precise diameter of the sieve rims cannot be predicted. In addition, sieves are available in both 2-in. and in mini-skirt models from many manufacturers and may be used interchangeably with 1-in. and 2-in. deep pans. Occasionally, a rim is so large in diameter that it supports several adjacent sieves causing wobbling and possible sieve separation. When the stack has been allowed to run long enough to automatically mark this high spot, the stack can be removed and the rubber cut away from the roller to provide bead clearance. With the rollers running, serrate the tire down to the metal shaft with a sharp knife. Stop the rollers and cut away this narrow (perhaps 1/2 in.) band.

### Cleaning the sieves

The sieves can be nondestructively cleaned by inverting the empty stack and running it in the sifter for perhaps 3 minutes. All nested, most lodged and some of the jammed particles will accumulate in the lid.

### Hammers

It is immaterial whether the hammers tap the frame or the bead of the sieves. Any hammer that is not covered by a sieve will be thrown quite high; by the time it has returned, it will be out of sequence with the rest of the gaggle. When using a short stack of sieves, the extra hammers can be removed to eliminate the unnecessary noise and broken rhythm.

## MAINTENANCE

### Hammers

To be effective, the hammers must be perfectly free to rotate on their shafts; if removal and cleaning of the shaft and nylon bearings with a solvent (such as alcohol) fails to free the assembly, replacement of the

Nyliner bearings may be necessary.

**DO NOT LUBRICATE!** Nylon is an excellent lubricant.

- To remove the hammer, open the -65 hammer detent spring.

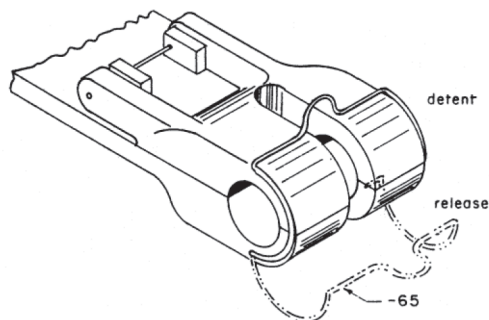

- Nylon sleeve bearings are wrapped off and on the shaft; their flanges contact the drive

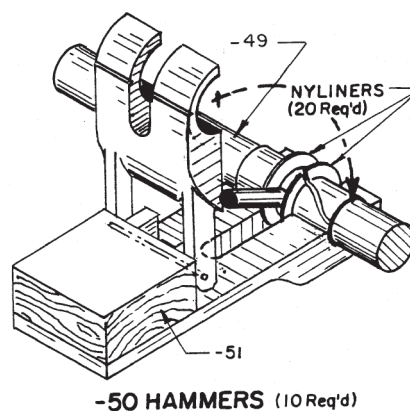

pin (which is straddled by the hammer). It may be necessary to replace the Nyliner bearings to provide perfectly free movement.

### Lubrication

Do not lubricate. All shafts and motor bearings are permanently sealed ball bearings, which cannot be lubricated. The replaceable nylon sleeve hammer bearings are installed on a ground stainless steel hammer shaft. No lubrication is required (wet lubrication will load these bearings with detrimental abrasives!) The replaceable -44 Nupla Face on the cam follower, is also run dry.



## V Belts

1) BEL1000 connects the drive motor with a jack shaft. Tension is adjustable by moving the motor closer to the side of the case. The four motor mounting slotted round head, screws are accessible on the sifter bed below the sieve rollers.

2) BEL1001 connects a roller with the cam pulley. It is tightened by relocating the self-aligning flange bearing on the cam shaft. Loosen the nuts of the attaching bolts, move the cam pulley downward, and retighten.

3) BEL1002 connects the jackshaft with the rollers. Tension is adjusted by relocating the jackshaft flange-type self-aligning bearing. Loosen the nuts, move the pulley down to tighten the belt. Re-secure.

## Rollers

The rubber covers of the rollers were factory installed using Cat. No. 635T ROLLER COVERING TOOL; if not available, the user will find it impossible to recover the shafts except by using many short pieces. A pair of rubber covered shaft assemblies are therefore offered for replacement; after installing the new shafts, it is suggested that the customer return his shafts for factory recovering or exchange if reusable.

### To do it yourself:

- 1) Remove the drive belt and drive pulley.
- 2) Using a 3/32 allen wrench, loosen the setscrews at the (upper) headboard bearing.
- 3) Remove the lower footboard bearing together with the roller through the footboard.
- 4) Release the lower bearing set screws and remove the dirt slinger washer and spacer ring.
- 5) Transfer the hardware to the new rollers.
- 6) Install in reverse order.

## Hammer shaft

Since the hammers can be individually removed and replaced, the removal of the shaft is unnecessary unless a self-aligning pillow block (bearing) requires replacement.

### To disassemble:

- 1) Remove the roller drive belt and two roller drive pulleys.
- 2) Unhook the cam spring at its upper end.
- 3) Unbolt both the upper and lower hammer shaft pillow blocks and their shaft lock set screws.
- 4) Remove the cam follower casting (set screw and key).
- 5) The shaft can then be jockeyed upward to clear the footboard and then downward to free it of the case.
- 6) Replace any malfunctioning parts and reinstall in the reverse order.

## Timer

The digital timer is not field repairable and should be sent to Rainhart for repair or replacement (part # ELC1041)

- 1) Push the emergency stop button on the control panel in.
- 2) Unplug the cord from the wall.
- 3) Remove the top service panel (3 screws)
- 4) Disconnect the two plugs from the back of the timer, DO NOT pull on the wires pull only on the plug itself; it may be necessary to use a small screwdriver to pry the plug off the But back of the timer.
- 5) Use a Philips screwdriver to loosen the two screws in the two mounting brackets on either side of the timer. Pivot the screw heads away from the timer and remove them from their sockets.
- 6) Slide the timer out of the control panel.
- 7) Replace the timer in reverse order.

## Motor

If the motor fails to start properly, first check the timer/switch. The following instructions will temporarily bypass the timer, emergency stop switch and relay, this will eliminate each as a source of the malfunction.

- 1) Disconnect the plug from the wall outlet.
- 2) There is a three conductor cord that runs from the motor (in the back of the cabinet) to the electronics (in the top of the cabinet). The three wires are black red and white. Remove the white wire from pin 2 of the solid state relay. Note that there are three white wires connected to pin 2 of the solid state relay; we are interested in the white wire that is part of the three conductor cord that runs up from the motor. Clamp it together with the red wire in this same cord under the screw on pin 1 of the solid state relay.
- 3) Keep in mind that you have bypassed the emergency stop button, therefore, when the power cord is plugged into the wall outlet the sifter will immediately start, unless of course there is a problem with the motor.

If the motor starts but growls and fails to gain normal speed almost immediately (the starting switch should click audibly), shut down almost immediately—servicing is required.

This is a common motor and can be serviced locally or it can be returned to Rainhart.

To remove the motor—

- 1) Unplug the sifter from the wall.
- 2) Have a helper support the motor while removing the four slotted round head mounting screws (found on the sifter bed under the rollers). The motor is secured with two strap nuts threaded to receive the motor mounting screws. The belt can be removed once the motor is unbolted.
- 3) Remove the cover plate from the bottom of the motor and disconnect the three conductor cable from the motor.
- 4) Reassemble in reverse order. The wiring diagram on the name plate for the motor illustrates the wiring configuration for low voltage.

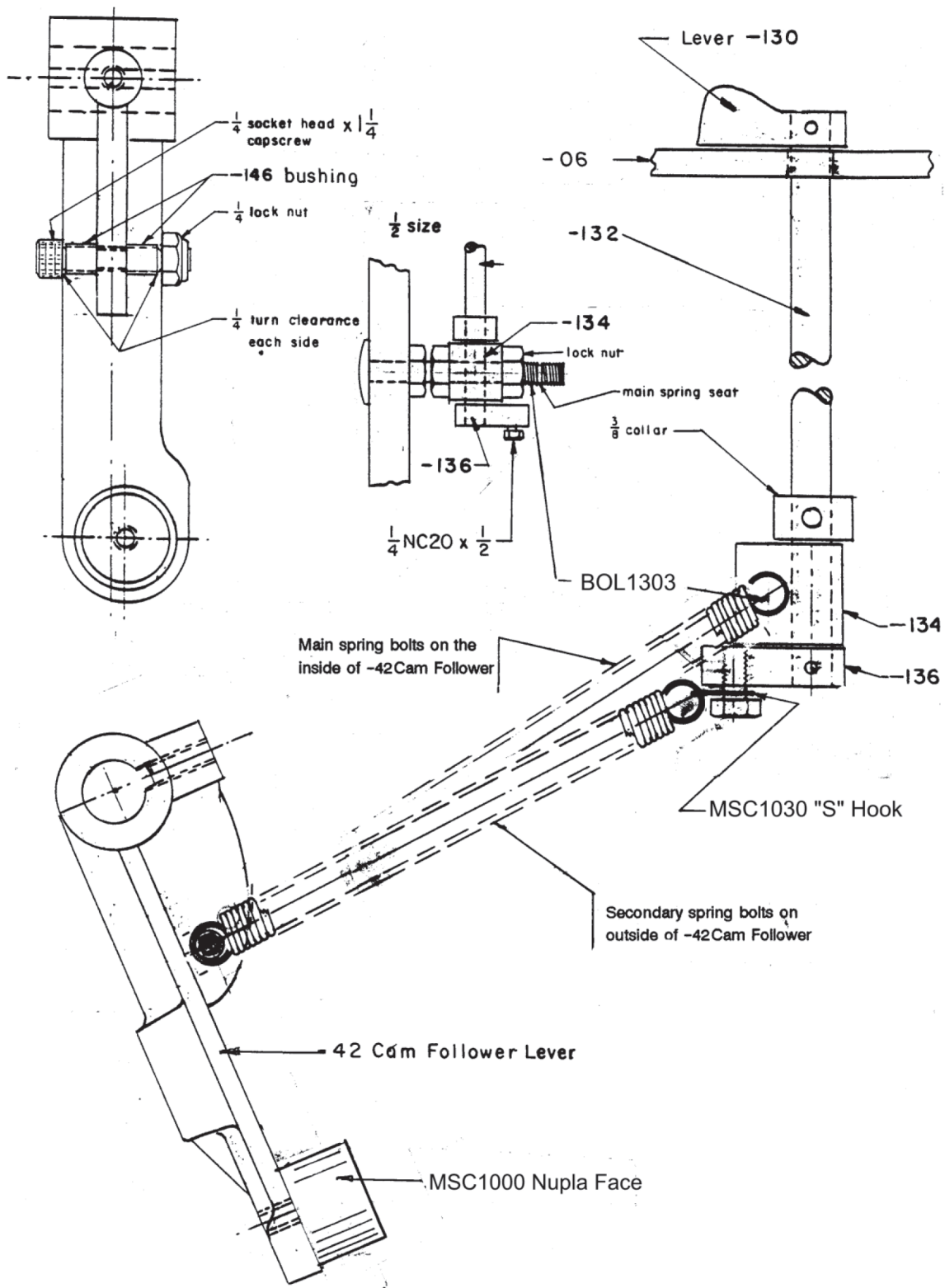

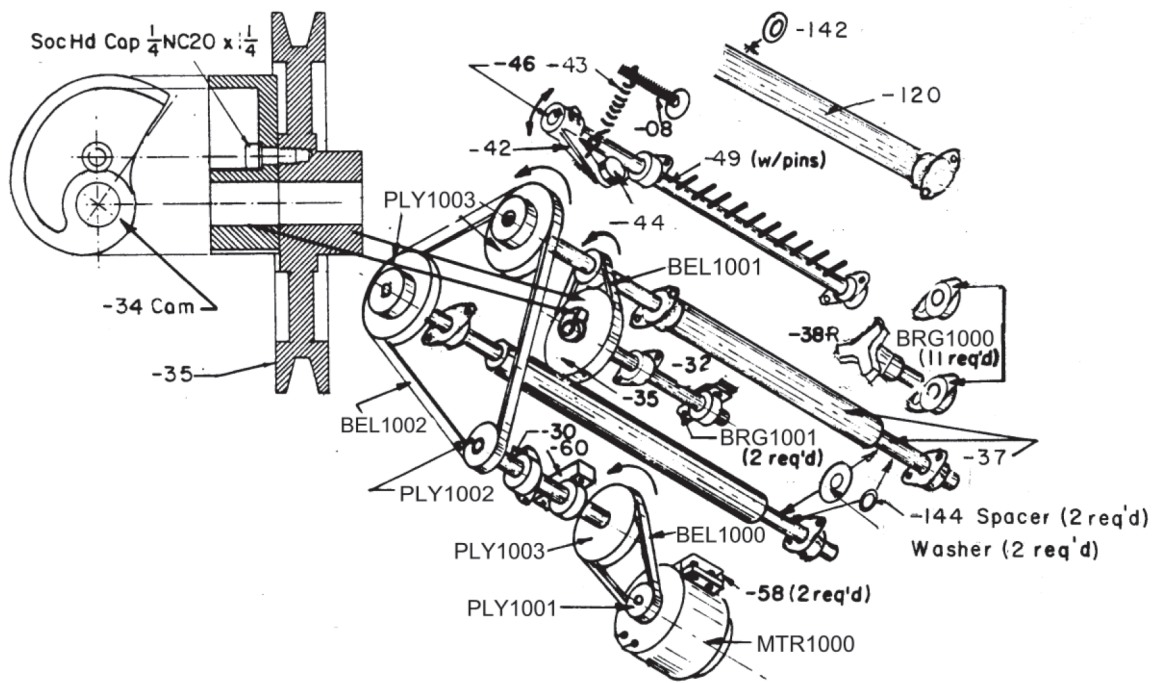

Pt #	Description	qty	Pt#	Description	qty
637D-06	Control Panel	1	637-110	Pivot plate, case	2
637-07D	Case w/lid and back	1	637-700	Roller, idler 29	1
637-1000	Door stop	1	637-130	Lever, extra spring lifter	1
BOL1303	Spring attaching carriage bolt	1	637-200	2nd spring mechanism	1
637-09	Hinge Bar, lid	1	637-200-132	Shaft	1
637D-10	Door hinge	1	637D-200-134	Bearing Block	1
637-13	Hinge Plate (al casting)	1	637-200-136	Spring crank	1
635-400-30	Jack Shaft x 11 1/2	1	MSC1030	S-hook	2
635-500-32	Cam Shaft x 10	1	637-142	Spacer	1
635-500-34	Cam	1	635-144	Spacer, .15 thick	3
635-500-35	Pulley 6 x 5/8 (mod. For cam)	1	635-146	Bushing	2
637-600	Rollers, main, 33 1/2	2	MTR1000	Motor, 1/3 hp 115VAC	1
635-38	Turntable	1	ELC1000	Cord set	1
635-800A	Cam Follower Lever	1	ELC1041	Digital timer	1
635-800B	Spring	2	BRG1000	Pillow block, (flange)	11
MSC1000	Nupla Face	1	BRG1001	Pillow block, (standard)	2
635-41	Keys, 3/16 sq. x 1	8	BEL1000	V-belt	1
637-300A	Hammer Shaft x 31 w/ tension pins	1	BEL1001	V-belt	1
635-300B	Hammer, complete	10	BEL1002	V-belt	1
635-300B-51	Clappers, maple block only	10	PLY1001	Pulley 1 3/4 x 1/2	1
635-58	Strap Nut	2	PLY1002	Pulley 1 3/4 x 5/8	2
635-59	Spacer for Cam Shaft Pillow Block	1	PLY1003	Pulley 3 1/2 x 5/8	3
635-60	Pad for Jackshaft (wood)	1	COL1000	Collar, 3/8	1
SPR1001	Hammer detent spring	10	MSC1020	Nyliners	20
637-100	Stand	1	ELC1104	Solid state relay	1
635-100-311	Rubber feet	4	ELC1250	E-stop with 2 contact blocks	1
637-106	Quadrant stops	2	ELC1222	Contact block	2
637-100-108	Pivot plate, apex	2			

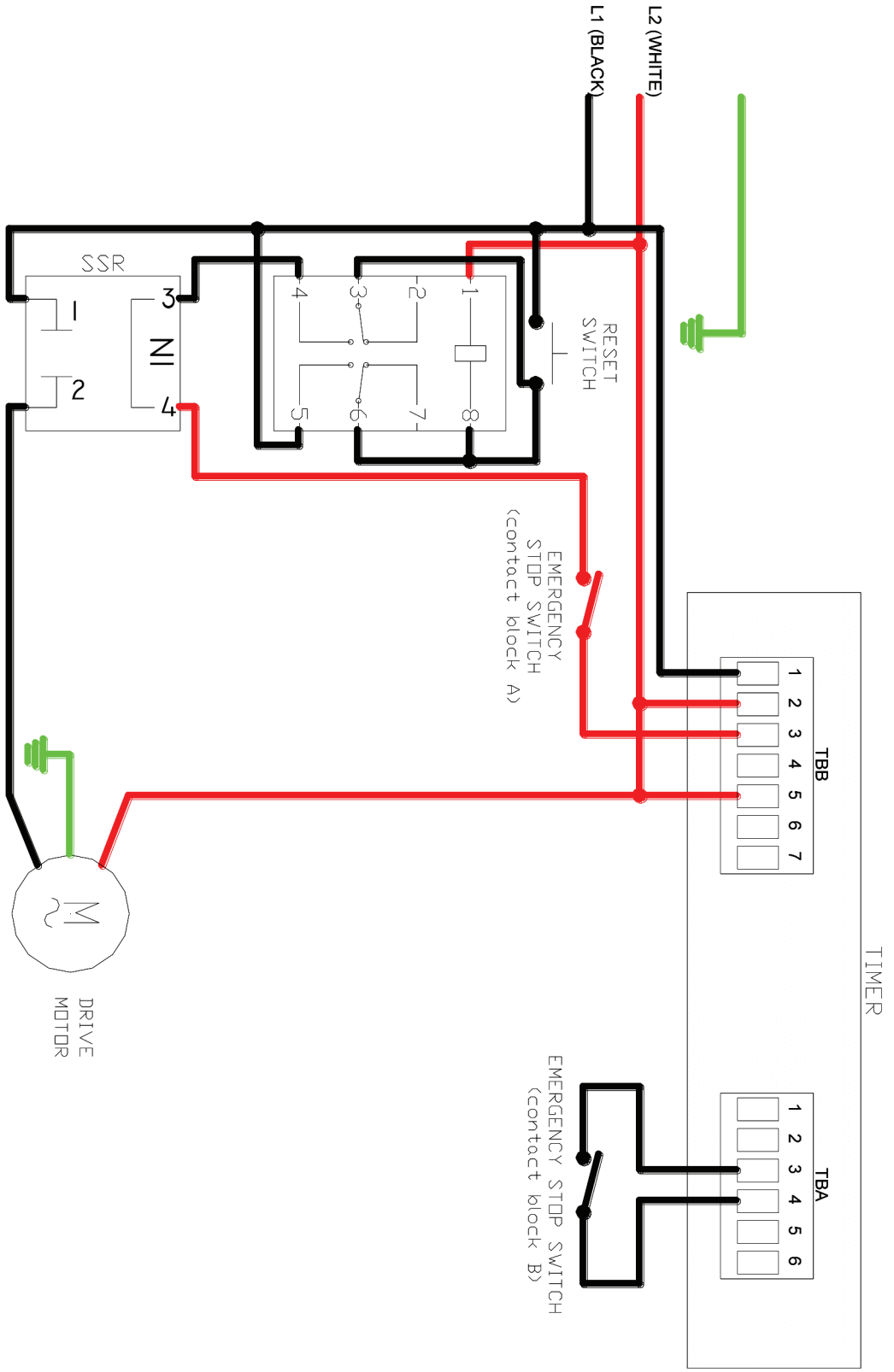

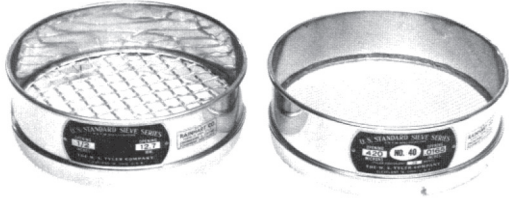

**SERIES TB8 U.S. STANDARD SIEVES, BRASS**—8 in. dia. (ASTM Designation: E 11). Polished brass frame with extended rim and nesting skirt. Coarse brass wire mesh, brass or bronze woven wire cloth permanently anchored tautly 2 in. below rolled top rim. For each sieve being ordered affix to Cat. No. US8 a hyphen (-) and designate the desired mesh (e.g. - Cat. No. US8-1 1/2 Cat No. US8-40). If half-height with mesh or cloth 1 in. below top rim is desired, also affix the letter "HB" (e.g. - Cat. No. US8-1 1/2HB; Cat. No. US8-40HB). Request quotation for other diameters or with round openings punched in plates. Approx. Ship. Wt. 3 lb.

**SERIES TS8 U.S. STANDARD SIEVES, BRASS W/ SS. MESH**—Same as above group except for having coarse stainless steel mesh or liner stainless steel woven wire cloth for corrosion resistance and longer service life. For each sieve being ordered affix to Cat. No. US8 a hyphen (-) and designate the desired mesh (e.g. - Cat No. US8-1 1/2; Cat. No. US8-40). If half-height with mesh or cloth 1 in. below top rim is desired, also affix the letter "HS" (e.g. - Cat. No. US8-1 1/2HS; Cat No. US8-40HS). Request quotation for other diameters or with stainless steel frames. Approx. Ship Wt. 3 lb.

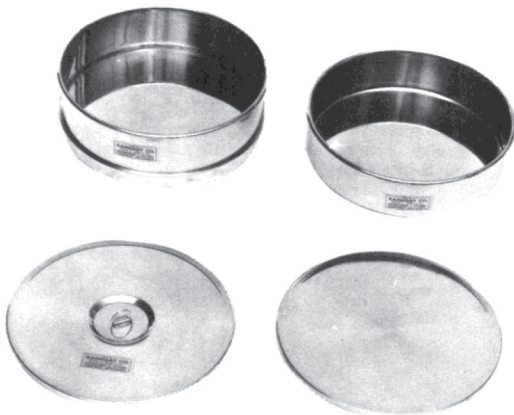

**SERIES TB8 STANDARD SIEVE ACCESSORIES**—Conventional designs in polished brass that fit all 8 in. dia. U.S. Standard Sieves. Request quotation for other diameters or in stainless steel. Approx. Ship Wt. 1/2 to 3 lb.

- CAT. NO. SSP-8-2 SIEVE PAN – With extended rim.
- CAT. NO. SP-8-1 SIEVE PAN – 1 in. deep.
- CAT. NO. SP-8-2 SIEVE PAN – 2 in. deep.
- CAT. NO. TB8CR SIEVE COVER -- With recessed ring.

## ACCESSORIES

### Scoops



For handling concrete, sand, soils, tec. In the laboratory or field. One-piece aluminum, satin finish. Approx. ship Wt: 2 lbs.

- CAT. NO. D29 SCOOP – (Round – 4" Width)
- CAT. NO. D30 SCOOP – (Square – 3 3/4" Width)

### Brushes

CAT. NO. RDD1 BRUSH – (Wood Handle)  
For cleaning FINE mesh sieves. Wood handle, with 1" wide bristles.

CAT. NO. RDD-2 BRUSH – (Wire loop handle)  
For cleaning COARSE mesh sieves. Wire loop handle with 1" side bristles. Approx. ship Wt. 1/4 lbs

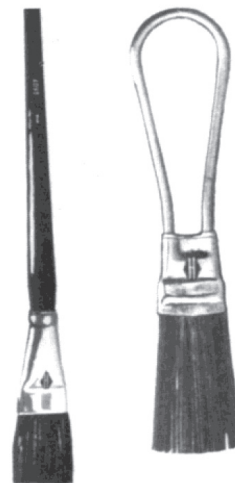



CAT. NO. RG TSA170 BRUSH, WIRE CLOTH (Bristle) – The round 1 ¼” dia. brush is a soft black bristle brush recommended for cleaning No. 16 and finer wire cloth. It has a nickel steel ferrule and clear lacquered handle. Overall length is 5-¾”. Ideal for round sieves and pans. Also useful for screen trays. Approx. shipping wt.: 2 lbs.

CAT. NO. RG TSA171 BRUSH, WIRE CLOTH (Brass for Trays) – it has 5½” of fine (.005) brass wire staple set in a 13” curved wooden handle. Wire slants to tip for cleaning corners of screen trays. Recommended for No. 30 and coarser wire cloth in trays only. Approx. ship wt.: .5 lbs.

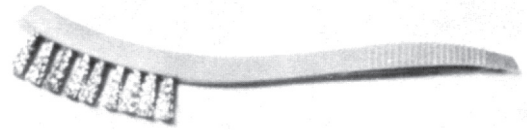

CAT. NO. RG TSA172 BRUSH, WIRE CLOTH (Brass – For Sieves) – For No. 30 and coarser in round sieves. This 8 1/2” curved plastic handle brush has 2 ½” x 3/8” of slanted brass wire – perfect for round sieves in coarse sizes. Approx. ship Wt.: .2 lbs.

CAT. NO. RT1778SB BRASS BRISTLE SIEVE BRUSH – For cleaning #100 and coarser meshes. Approx. Ship Wt. 2 lbs.

CAT. NO. RTNBSB NYLON BRISTLE SIEVE BRUSH – For cleaning #100 and finer meshes. Approx. ship Wt. 2 lbs.



500 Brushy Creek Road, Suite 506, Cedar Park, TX 78613  
tel: (512) 452-8848 | fax: (512) 452-9883 | [www.rainhart.com](http://www.rainhart.com) | [sales@rainhart.com](mailto:sales@rainhart.com)

