

MCS-425

Microwave Detector



- Operating voltage 12~24Vdc/Vac
- Black ABS plastic
- Microwave
- Adjustable
- COM / NO / NC
Change-over-contacts

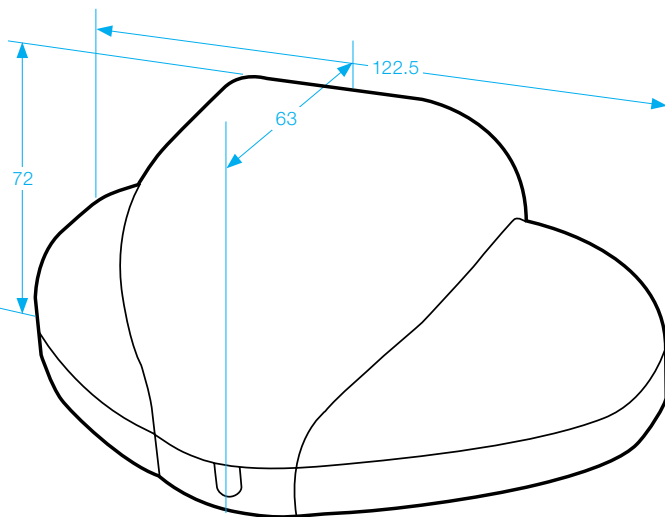

Fig A. The Connection for Fail-Safe lock devices

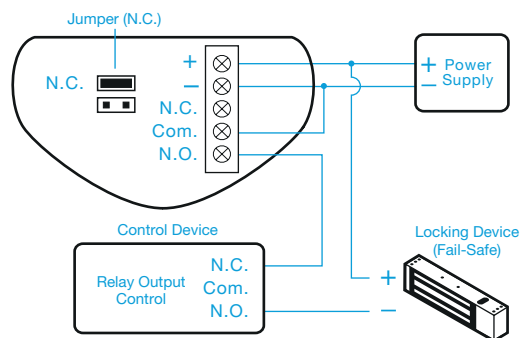
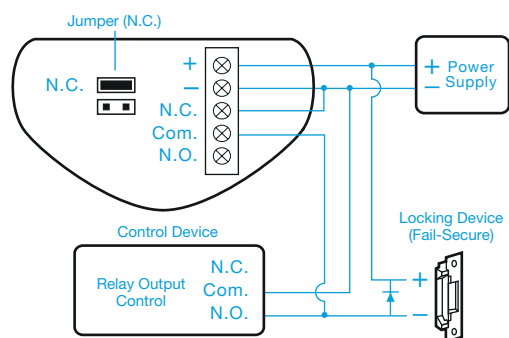

Fig B. The Connection for Fail-Secure lock devices



SPECIFICATION

- Voltage tolerance: ±15%
- Current draw: 80mA (at temperature 20°C)
- Operating temperature: -20~55°C (-4 to 131°F)
- Frequency: 10.535GHz
- Relay rated: 3A/120Vac; 3A/24Vdc
- Relay actuation time: 0.5~4 Seconds
- Sensor angle: 7.5°~82.5°