

# GL1200NTBR

## Standard Stainless Steel Magnet



- Operating voltage 12~24Vdc
- Holding force up to 1200lbs (545kg)
- Standard or face fix



WEATHER  
RESISTANT  
– IP 67 –



VANDAL  
RESISTANT



STAINLESS  
STEEL

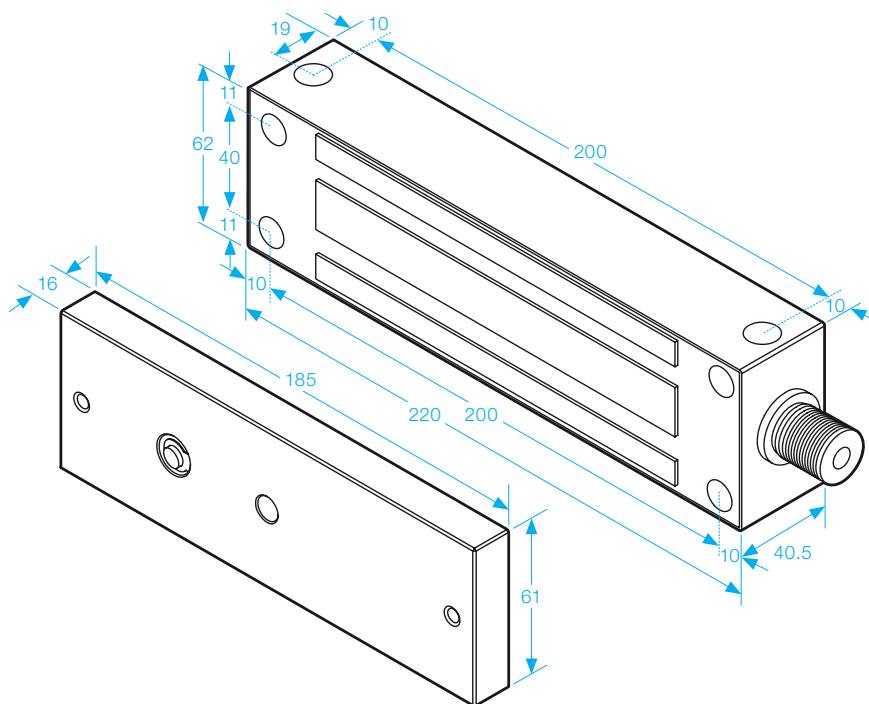

### WATERPROOF PROPERTIES

This series of waterproof magnetic locks are sealed with an epoxy potting compound (E87252 (S), UL94V-0) and is protected by this compound. They are proved to withstand a water resistance as established in test procedures of IP 65.



### SPECIFICATION

- Voltage tolerance:  $\pm 15\%$ .
- Current draw: 460mA at 12Vdc (at temperature 20°C).
- Operating temperature: -10~55°C (14 to 131°F).
- Lock's surface temperature: Current temperature  $\pm 20\%$  (when power is on).
- Magnetic bond sensor monitor output remotely monitors the door lock or unlock status. (N.C. Output-Door opened; N.O. Output-door closed) (SPDT rated 0.25A at 12Vdc).
- Humidity: 0~95% non-condensing.
- Special Zinc finish for magnet and armature plate.
- Weight: 5.0kg (approx).