

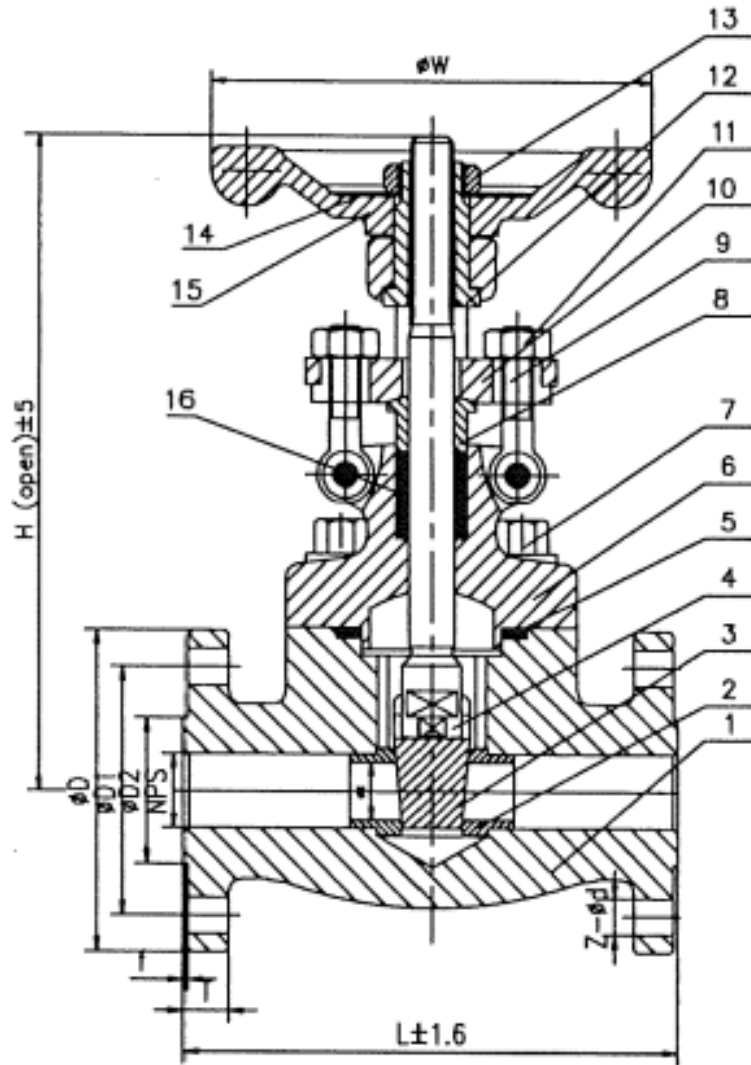

**TURCOMP**



No.	Part Name	Material
1	Body	ASTM A105
2	Seat Ring	ASTM A182 F6a + STL
3	Wedge	ASTM A182 F6a
4	Stem	ASTM A182 F6a
5	Gasket	SS + Graphite
6	Bonnet	ASTM A105
7	Hex. Bolt	ASTM A193 B7
8	Gland	ASTM A182 F6a
9	Gland Eyebolt	ASTM A193 B7
10	Gland Flange	ASTM A105
11	Gland Nut	ASTM A194 2H
12	Yoke Nut	ASTM 1035
13	H.W. Nut	ASTM A194 2H
14	Nameplate	SS304
15	Handwheel	Malleable Iron
16	Packing	Flexible Graphite

DIM											
	L	D	D1	D2	Z- $\Phi$ d	T	f	d	H	W	
NPS 1/2"	140	95	66.5	35	4- $\Phi$ 16	14	2	10.3	165	96	
NPS 3/4"	152	117.5	82.5	43	4- $\Phi$ 19	16	2	13.5	169	96	
NPS 1"	165	124	89	51	4- $\Phi$ 19	17.5	2	18	217	120	
NPS 2"	216	165	127	92	8- $\Phi$ 19	22.5	2	36	243	171	