

# Y-STRAINER DIN STANDARD

CAST IRON / CARBON STEEL / STAINLESS STEEL

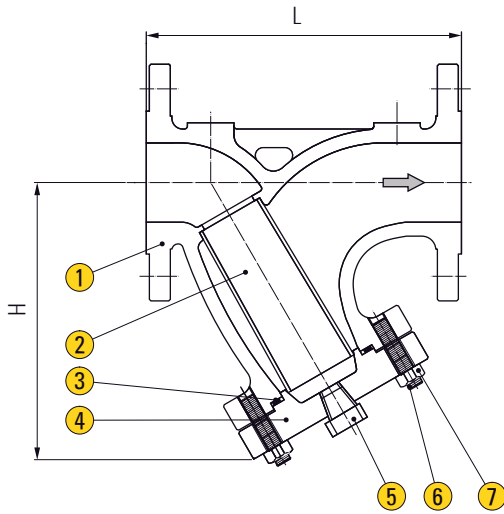

**FIG 821 X - X**

Material		Connection
- A126	- C5	- PN16
- WCB / CS	- CF8	- PN40
- LCB	- CF8M	- Butt weld
- LCC	- CF3	- Socket weld
- WC1	- CF3M	- RTJ
- WC6	- CF8C	

## APPLICATION

Suitable for water, steam, oil, gases and others non-abrasive media (Refer to corrosion resistance table for valve materials selection).

## SPECIFICATION

Face To Face Dimension Series 1 according to EN 558-1  
 End Connection Flange end to DIN PN16 and PN40  
 Perforated Screen Diameter 1mm for DN15 to DN50  
 1.25mm for DN100 to DN300  
 1.6mm for DN100 to DN300  
 Mesh Size 20 / 40 / 60 / 80 / 100

## MATERIAL

Parts	Material				
1 Body	A126	WCB	CF8	CF8M	CF3M
2 Screen	SS304	SS304	SS304	SS316	SS316L
3 Gasket	Graphite				
4 Cover	A126	WCB	CF8	CF8M	CF3M
5 Plug	SS304	SS304	SS304	SS316	SS316L
6 Cover Bolt	HT 8.8	HT 8.8	SS304	SS316	SS316L
7 Cover Nut	HT 8.8	HT 8.8	SS304	SS316	SS316L

## DIMENSIONS

Unit : mm

Class	Size (mm)	15	20	25	32	40	50	65	80	100	125	150	200	250	300
PN16	L	130	150	160	180	200	230	290	310	350	400	480	600	730	850
	H	90	100	115	135	150	160	180	215	235	280	320	405	540	680
PN40	L	130	150	160	180	200	230	290	310	350	400	480	600	730	850
	H	70	80	88	100	125	140	170	190	225	260	320	420	540	680

\*Specification given are subject to changed without further notice.