

SWING CHECK VALVE

ANSI STD

BODY - CAST IRON

CAST IRON

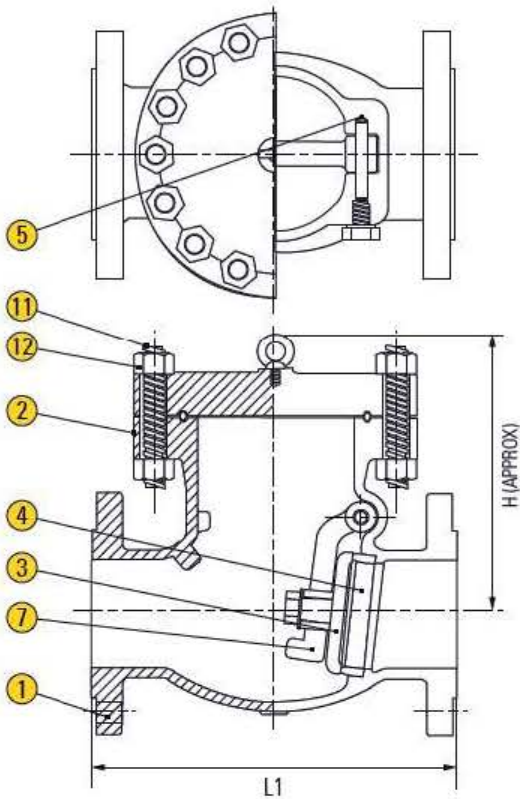

FIG SC-*1-*2-*3

Note: *1 Class | *2 Material | *3 Connection

SPECIFICATION

Designed and Manufactured
 Face To Face Dimension
 Pressure Rating
 Flange End Dimension

API 6D
 ASME 16.10
 Class 150
 ASME B16.5

Test and Inspection
 Pressure - Temperature Rating

API 598
 ASME B16.34

MATERIAL

Parts	Standard
	1 Body
2 Cover	A126 B
3 *Disc	A217-CA15
4 Body Seat Ring	A105+HARD FACE
5 Hinge Pin	A276-410
7 Arm	A216-WCB
11 Cover Bolt	A193-B7
12 Cover Nut	A194-2H

CLASS 150

Valve Size	inch	2	2½	3	4	5	6	8	10	12
	mm	50	65	80	100	125	150	200	250	300
L1 & L3	inch	8.0	8.5	9.5	11.5	13.0	14.0	19.5	24.5	27.5
	mm	203	216	241	292	330	356	495	622	699
H	inch	6.1	6.7	7.3	7.9	9.3	10.0	12.0	13.6	15.0
	mm	155	170	185	200	235	255	305	345	380
Weight	LB	33.1	48.5	59.5	90.4	143.3	176.4	313.1	390.3	639.5
	Kg	15	22	27	41	65	80	142	177	290

*Specification given are subject to changed without further notice.