

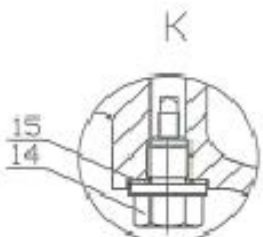

TURCOMP

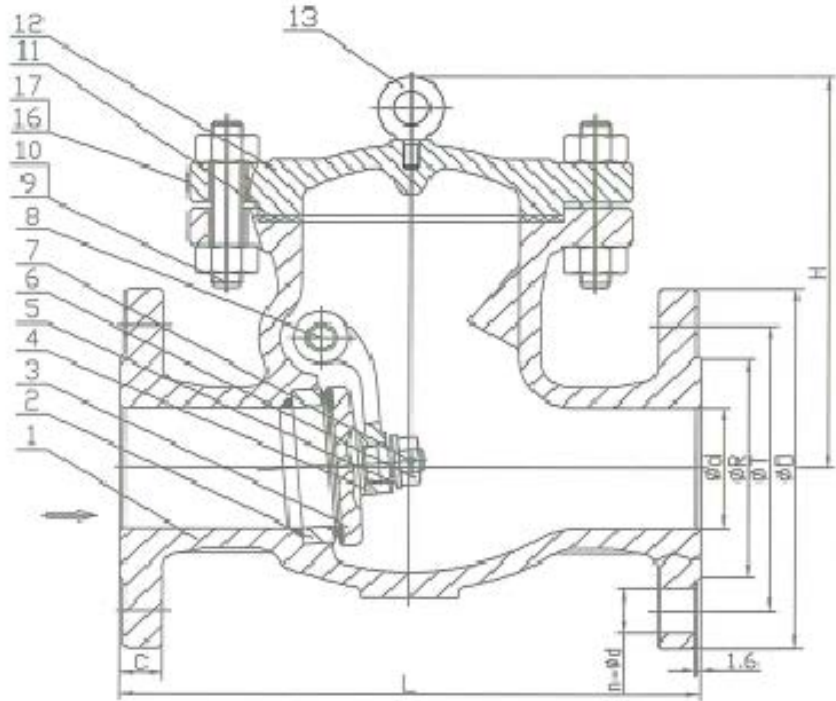

No.	Part Name	Material
1	Body	ASTM A216 GR. WCB
2	Seat Ring	ASTM A105 + STL #6
3	Disc	ASTM A105 + CR13
4	Hinge	ASTM A216 GR. WCB
5	Disc Washer	ASTM A276 TYPE 410
6	Disc Nut	ASTM A276 TYPE 410
7	Disc Nut Pin	ASTM A276 TYPE 410
8	Hinge Pin	ASTM A182 GR F6A
9	Stud	ASTM A193 GR.B7
10	Nut	ASTM A194 GR.2H
11	Gasket	SPW SS304 + Graphite
12	Bonnet	ASTM A216 GR.WCB
13	Eyebolt	Carbon Steel
14	Plug	ASTM A276 Type 410
15	Washer	ASTM A276 Type 304
16	Nameplate	SS316
17	Rivet	SS316

DIM NPS	Φd	ΦR	ΦT	ΦD	n-Φd	C	L	H	W(KG)
	4	102	157	200	254	8-Φ22	32	356	256
6	152	216	270	318	12-Φ22	37	444	306	131